

AR25

Smart Programmable 25-Bit Reflective Absolute Single-Turn Encoder

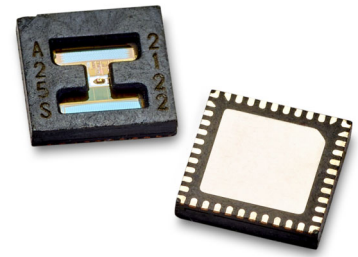

Overview

The Broadcom[®] AR25 is a miniature absolute encoder ASIC that is designed to cater to the growing demand for space-constraint applications. Employing the advanced reflective optical-encoding theory, the AR25 Series offer high position accuracy with a correction algorithm, which is unattainable by the magnetic encoders.

The AR25 encoder is a one-chip solution that has the flexibility to cater to variable overall diameters, ranging from 30 mm to 60 mm. The AR25 also supports through-hole solutions up to 30 mm in diameter. User-programmable resolutions are from 15-bit to 25-bit single-turn absolute outputs. In addition, the AR25 also provides differential analog sine/cosine or digital incremental ABIUVW signals with configurable CPRs and pole-pairs. The AR25 also comes with a state-of-the-art Auto-Calibration feature that eases customer's integration into their end systems.

The AR25 Series also supports integration with the Broadcom proprietary battery-less Energy Harvesting Multi-Turn (EHMT) solution. Alternatively, other multi-turn solutions like gear-based and battery backup are also supported by a dedicated MT interface port.

For power supply, the ASIC supports dual-mode operating voltages of either 3.3V or 5V, which are suitable for handheld and portable device applications. The operating temperature range is -40°C to 125°C , suitable for most industrial applications.

To enhance the user system-design flexibility, the AR25 offers various protocols that are selectable by the user. Among the available protocols are the Encoder Serial Link (ESL) or RS485 half-duplex protocol, SSI, BiSS-C, and SPI 4-wire.

Features

- Miniature surface-mount QFN package: 6 mm (L) × 6 mm (W) × 1.05 mm (H)
- User-programmable absolute resolution: 15 bits to 25 bits
- User-programmable incremental output (ABI) resolutions ranging from 1 CPR to 2^{20} CPRs
- User-programmable commutation signals (UVW) ranging from 1 to 32 pole-pairs
- High-temperature range of -40°C to 125°C suitable for most industrial operations
- Dual-mode operating voltages of 3.3V and 5V, enabling handheld and portable device applications
- Multi-turn integration: EHMT, gear, or battery backup
- Optical radius (ROP) flexibility: Blind-hollow or through-shaft applications
- Built-in line transceiver for protocol with selectable drivability strength
- Auto-accuracy calibration with a constant speed that is one click away
- Selectable communication protocols:
 - RS485 (2.5/5/10 Mb/s)
 - ESL (2.5/5/10 Mb/s)
 - SSI 2-wire (up to 10 MHz)
 - SPI 4-wire (up to 10 MHz)
 - BiSS-C (up to 10 MHz)
- External memory support up to 128 Kb
- Built-in temperature sensor
- RoHS compliance

Applications

- Robotic automation and engineering
- Factory automation and drone
- Medical and dentistry devices and equipment
- High-accuracy portable and handheld devices
- Miniature motor, servo motor, and linear actuator
- Through-shaft motor, gear motor, and speed reducer

NOTE: This product is not specifically designed or manufactured for use in any specific devices. Customers are solely responsible for determining the suitability of the product for its intended application and solely liable for all loss, damage, expense, or liability in connection with such use.

Functional Description

Figure 1: AR25 Block Diagram

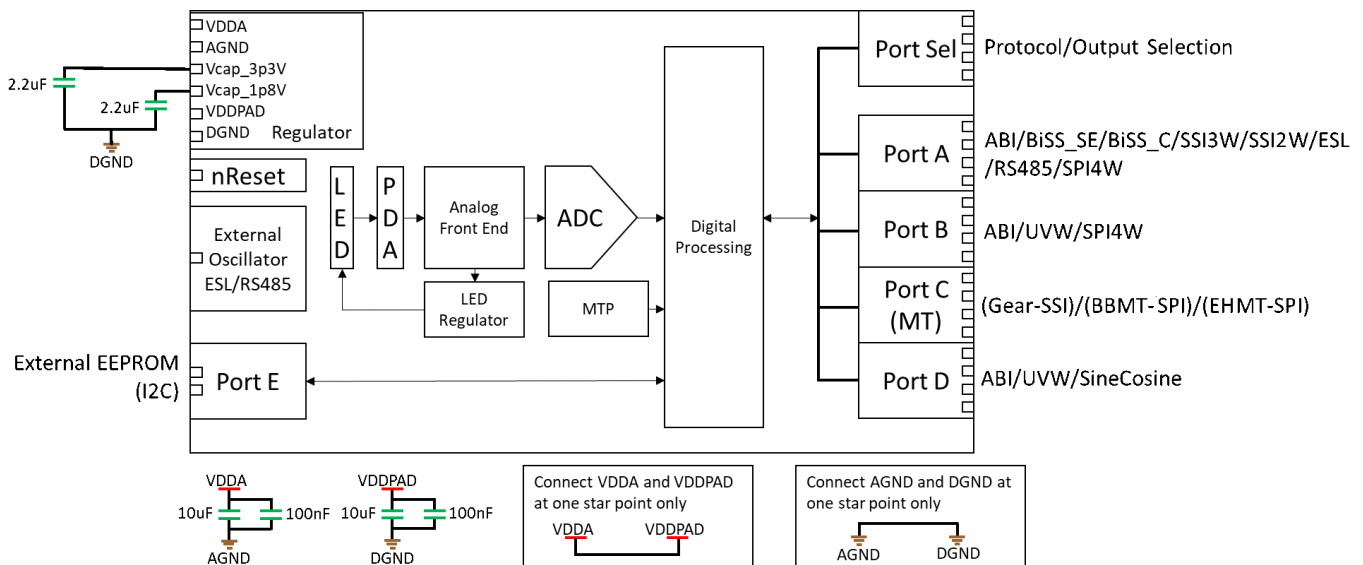

Figure 2: AR25 External Oscillator Connection Diagram

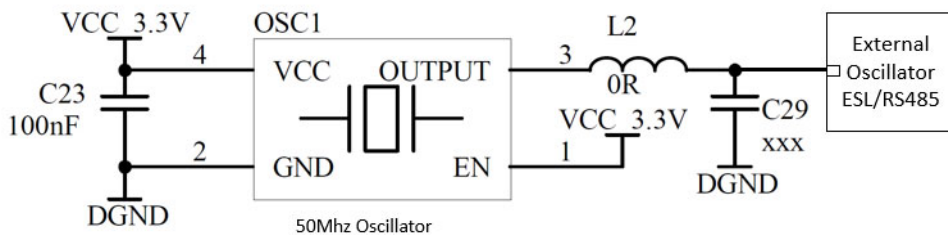

Figure 3: AR25 External EEPROM Connection Diagram

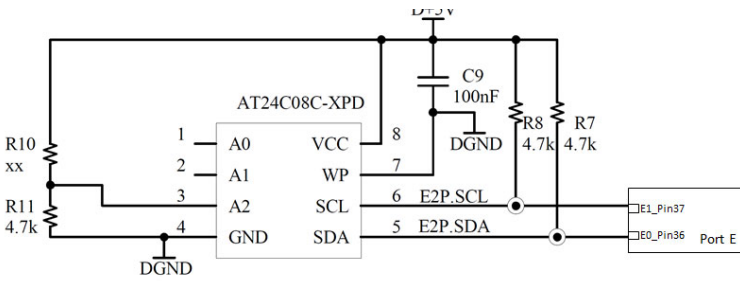
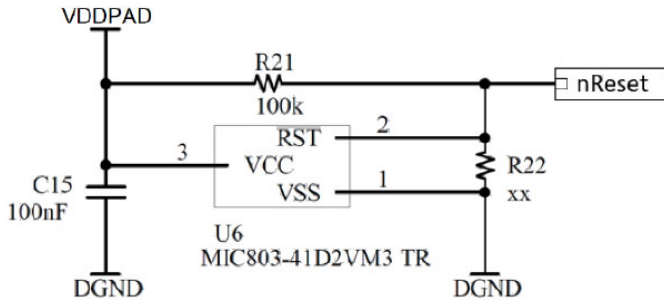

Figure 4: AR25 External nReset Connection Diagram



For more design details, refer to the AR25 Series application note (document number: AR25-Series-AN1xx).

Mechanical Dimension

Figure 5: Overall Package Dimension and Pinout

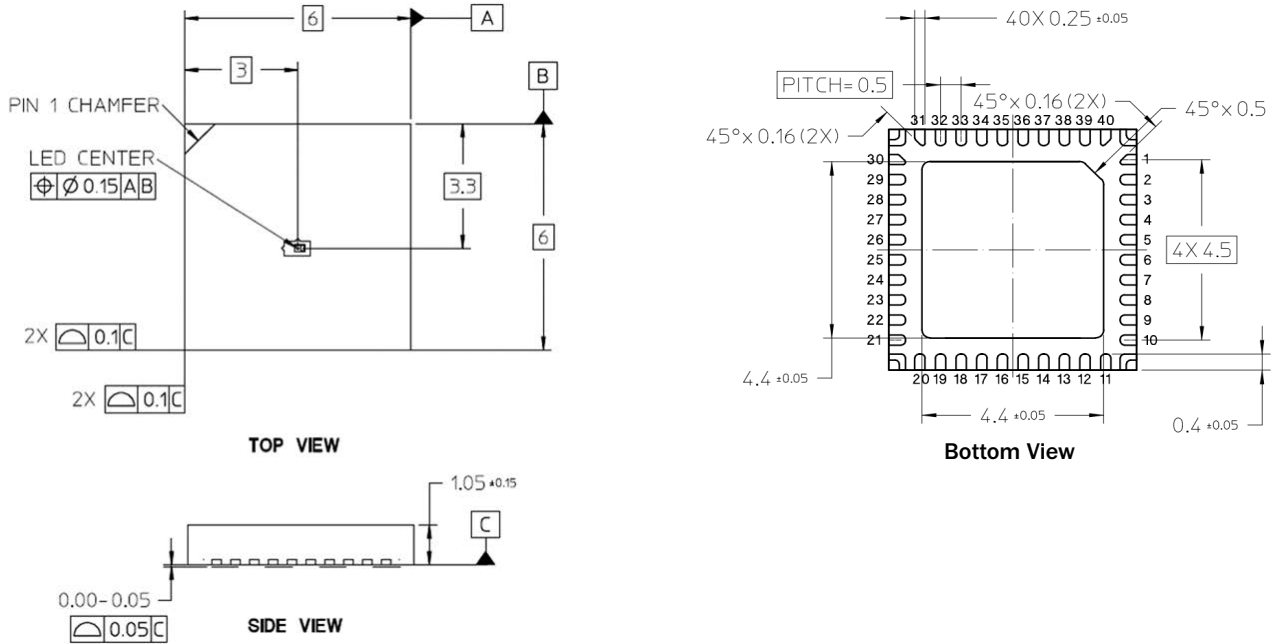

All dimensions are given in mm.

Table 1: Pinout

Pin	Name	Function
1	Port_B3	The I/O protocol depends on the Port_SEL[3:0] or internal register selection.
2	Port_B2	
3	Port_B1	
4	Port_B0	
5	VDDPAD	Digital power 3.3V/5V.
6	DGND	Digital ground.
7	Port_A3	The I/O protocol depends on the Port_SEL[3:0] or internal register selection.
8	Port_A2	
9	Port_A1	
10	Port_A0	
11	No Connection	Open/no connection.
12	No Connection	
13	No Connection	
14	No Connection	
15	No Connection	
16	No Connection	
17	No Connection	
18	No Connection	
19	No Connection	
20	No Connection	

Pin	Name	Function
21	Port_C0	The multi-turn I/O protocol depends on the Port_SEL[3:0] or internal register selection.
22	Port_C1	
23	Port_C2	
24	Port_C3	
25	AGND	Analog ground.
26	VDDA	Analog power 3.3V/5V.
27	Port_D0	Incremental and analog output depends on the Port_SEL[3:0] or internal register selection.
28	Port_D1	
29	Port_D2	
30	Port_D3	
31	nRESET	Power-up delay or ASIC reset pin.
32	Port_SEL0	Protocol selection or output selection pin.
33	Port_SEL1	
34	Port_SEL2	Refer to the AR25 Series application note for selection details.
35	Port_SEL3	
36	Port_E0	I ² C SDA external EEPROM.
37	Port_E1	I ² C SCL external EEPROM.
38	VDDcap_1p8V	Buffer capacitor 1.8V.
39	VDDcap_3p3V	Buffer capacitor 3.3V.
40	External Oscillator	50-MHz external oscillator input.

NOTE: For more details on the PORT_SEL[3:0] selection, refer to the AR25 Series application note.

Package Marking

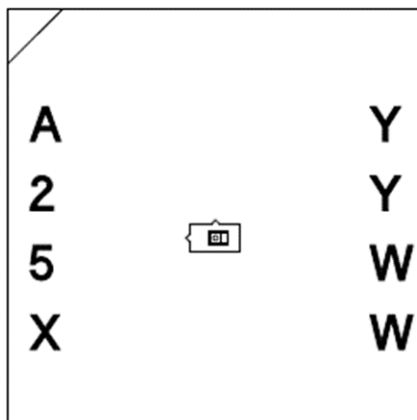
Figure 6: Product Marking Information

MARKING CONFIGURATION

PART NUMBER	PROTOCOL	MARKING
AR25S	STANDARD	A25S
AR25B	BISS	A25B

YYWW: YEAR, WORK WEEK

Encoder Mounting

Figure 7: Encoder Mounting Details

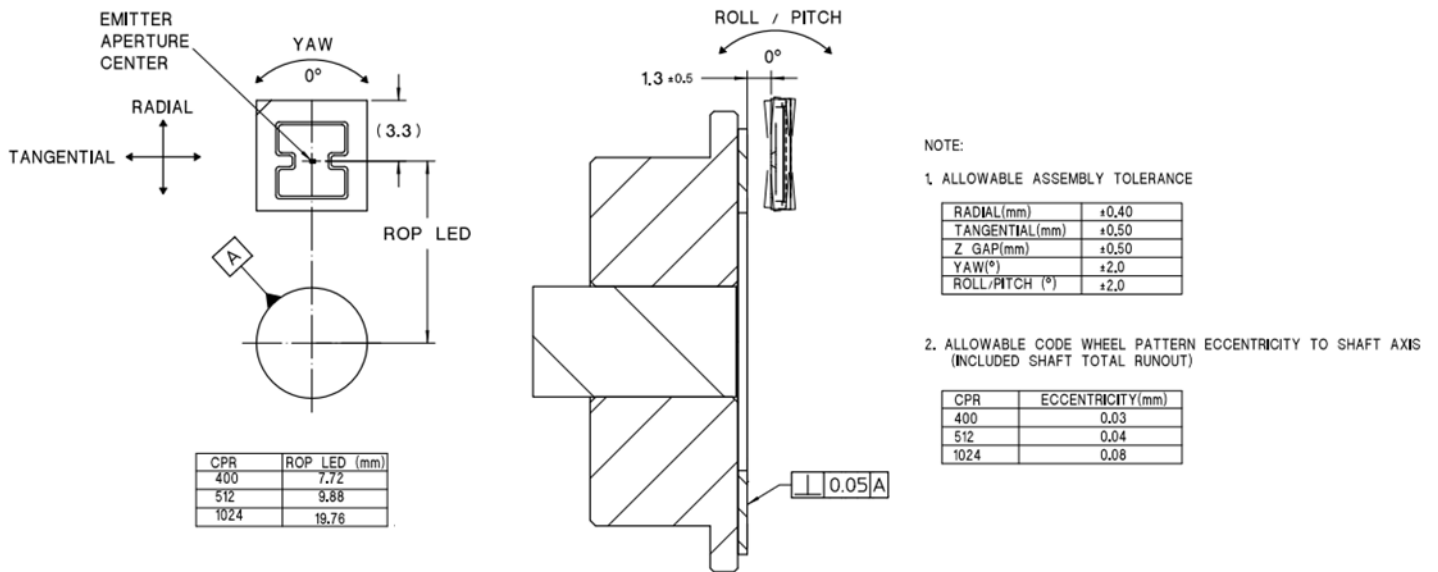

NOTE: The assembly of the encoder needs clean room conditions, Class 100K or better.
 The encoder must be enclosed with an IP50 or higher rating enclosure.
 For more mechanical design requirements, refer to the AR25 Series application note.

Absolute Maximum Ratings

Table 2: Absolute Maximum Ratings

Parameter	Symbol	Value
Storage temperature	T_S	-40°C to 125°C
Operating temperature	T_A	-40°C to 125°C
Supply voltage	V_{dd}	7V
ESD (HBM), JS-001-2014	—	±2 kV
Moisture sensitive level	MSL	3 (Maximum floor life = 168h)

NOTE:

1. Proper operation of the encoder cannot be guaranteed if the maximum ratings are exceeded.
2. Remove Kapton tape only after the SMT reflow process and just before final assembly. Take precautions to keep the encoder ASIC clean at all times.
3. Clean room conditions, Class 100K or better.
4. Some particles can be present on the surface of the encoder ASIC surface. The presence of these particles can degrade the performance of the encoder.

CAUTION! Anti-static discharge precautions should be taken when handling the encoder in order to avoid damage and/or degradation induced by ESD.

Electrical Specifications

Table 3: Recommended Operating Conditions

Parameter	Symbol	Min.	Typ.	Max.	Unit	Notes
DC supply voltage 5V	V_{dd}	+4.5	+5.0	+5.5	V	—
DC supply voltage 3.3V	V_{dd}	+3.0	+3.3	+3.6	V	—
Ripple of supply voltage	—	—	—	100	mVpp	100 kHz
Output current per channel	—	—	—	±5	mA	Single-ended
Rise time	t_r	—	30	—	ns	$C_L = 50$ pF
Fall time	t_f	—	30	—	ns	$R_L = 1.2$ kΩ
Ambient temperature	T_{amb}	—	+25	—	°C	—
Operational temperature	T_{PCB}	-40	+25	+125	°C	PCB (FR4-4 layers) temperature
Storage temperature	T_S	-40	+25	+125	°C	—
Humidity	RH	—	—	85	%	Temp = 40°C
INC operating frequency	—	—	—	128	kHz	Velocity (rpm) × CPR/60
Tangential misalignment	—	-500	Nominal	+500	μm	Below 512 CPR, spatial tolerance is ±400 μm
Radial misalignment	—	-400	Nominal	+400	μm	
Gap	—	-500	Nominal	+500	μm	
Encoder shaft speed	SRPM	—	—	15,000	rpm	512 CPR (AR25)
Temperature sensor accuracy	—	—	±3	—	°C	At 125°C

Table 4: Recommended Code Wheel Characteristics

Parameter	Symbol	Min.	Typ.	Max.	Unit	Notes
Specular reflectance	R_f	60%	—	—	—	Reflective area
		—	—	5%		Nonreflective area

NOTE: Characteristics based on Broadcom qualified code wheel suppliers. Contact Broadcom for qualified reflective code wheel suppliers.

DC Characteristics

Table 5: DC Characteristics over Recommended Operating Range, Typical at 25°C

Parameter	Symbol	Conditions	Min.	Typ.	Max.	Unit	Notes
VDD supply current	I_{DD}	$V_{DD} = 3.3V$	—	65	—	mA	—
		$V_{DD} = 5.0V$	—	65	—	mA	—
Absolute single-turn resolution	ST_{bits}	—	15	—	25 ^a	bit	—
Incremental resolution	—	—	2 ⁰	—	2 ^{nmax}	CPR	$n_{max} = 20$
Protocol I/O drive strength	I_{DIO}	$V_{DD} = 3.3V/5V$	5	20	40	mA	Differential driver
Differential transceiver hysteresis	V_{hys}	$V_{DD} = 3.3V/5V$	—	100	—	mV	220Ω termination
Differential transceiver opening	V_{open}	$V_{DD} = 3.3V/5V$	200	—	—	mV	
Differential transceiver voltage peak-peak	V_{PP}	$V_{DD} = 3.3V/5V$	—	2	—	V	
Output high voltage	V_{OH}	$V_{DD} = 3.3V$	2.4	3.3	3.6	V	No load
Output low voltage	V_{OL}		0	—	0.4	V	
Input high voltage	V_{IH}		2	—	3.6	V	
Input low voltage	V_{IL}		0	—	1.4	V	
Output high voltage	V_{OH}	$V_{DD} = 5.0V$	4.4	5	5.5	V	No load
Output low voltage	V_{OL}		—	—	0.5	V	
Input high voltage	V_{IH}		2.8	—	5.5	V	
Input low voltage	V_{IL}		0	—	1.8	V	

a. Maximum number of bits able to be set in the AR25.

Encoder Characteristics

Table 6: Incremental Encoder Characteristics over Recommended Operating Condition, at 25°C

ABI Parameter	Symbol	Min.	Typ.	Max. ^a	Unit
Cycle error	ΔC	—	—	45	edeg (electrical degree)
State error	ΔS	—	—	45	edeg
Index pulse width	P_o	—	90, 180, 270, 360	—	edeg

a. Maximum values represent the encoder performance across the range of recommended mounting tolerance.

Table 7: Commutation Characteristic over Recommended Operating Condition, at 25°C

Commutation (UVW) Parameter	Symbol	Min.	Typ.	Max. ^a	Unit
Commutation accuracy (middle of channel I to channel U)	ΔI	-1.0	0.1	+1.0	mdeg (mechanical degree)
Commutation accuracy (channel U, V, and W)	ΔUVW	-1.0	0.1	+1.0	mdeg

a. Maximum values represent the encoder performance across the range of recommended mounting tolerance.

Table 8: Encoder Raw Accuracy Characteristics over Recommended Operating Condition, at 25°C

Parameter	Symbol	Min.	Typ. ^a	Max.	Unit
Raw accuracy (AR25)	—	—	±350	—	arcsecond
Accuracy_AutoCal (Speed) ^b	—	—	±120	—	arcsecond
Accuracy_ManualCal (Reference Encoder) ^c	—	—	±30	—	arcsecond

a. Typical values represent the encoder performance with shaft TIR < 10 μm , $\phi 5.991 \sim 5.996 \text{ mm}$; code wheel hub inner diameter = 6.000 ~ 6.008 mm.

b. Typical values represent calibration with a motor speed ripple of < 0.1%.

c. Typical values represent the accuracy and repeatability when calibrated with a reference encoder having 10× higher accuracy than the AR25. (AR25 = 25 bit; Reference Encoder = <3 arcsecond).

Mechanical Specification

Table 9: Encoder Product Mechanical Design Guide (Size)

Parameter	Code Wheel Inner Diameter (Max.)	Code Wheel Outer Diameter (Min.)	Product Outer Diameter (Min.)	Motor Shaft (Max.)	Unit
400 CPR	10	20	30	6	mm
512 CPR	15	25	35	12	mm
1024 CPR	35	45	55	30	mm

Ordering Information

Table 10: Product Ordering Information

Part Number	Description
AR25-AS01	AR25 single-turn absolute encoder with standard protocols 100 pcs
AR25-AB01	AR25 single-turn absolute encoder with BiSS-C 100 pcs
AR25-AS02	AR25 single-turn absolute encoder with standard protocols 1000 pcs
AR25-AB02	AR25 single-turn absolute encoder with BiSS-C 1000 pcs

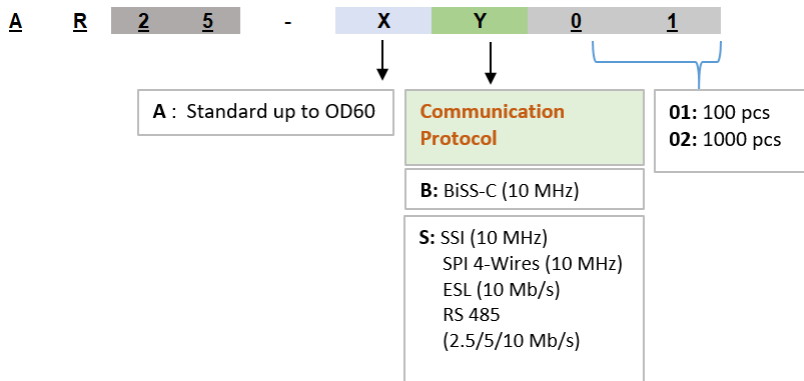

Part Number	Description
AR25-A12T	Aluminum code wheel (512 CPR), through-hollow inner diameter (6 mm)
AR25-A13T	Aluminum code wheel (512 CPR), through-hollow inner diameter (8 mm)
AR25-A18T	Aluminum code wheel (512 CPR), through-hollow inner diameter (12 mm)
AR25-A15T	Aluminum code wheel (1024 CPR), through-hollow inner diameter (15 mm)
AR25-A20T	Aluminum code wheel (1024 CPR), through-hollow inner diameter (20 mm)
AR25-A30T	Aluminum code wheel (1024 CPR), through-hollow inner diameter (30 mm)

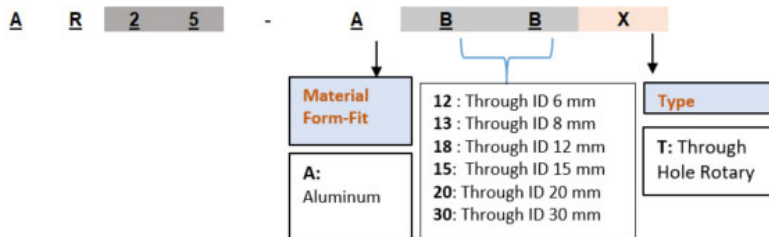

Packaging Information

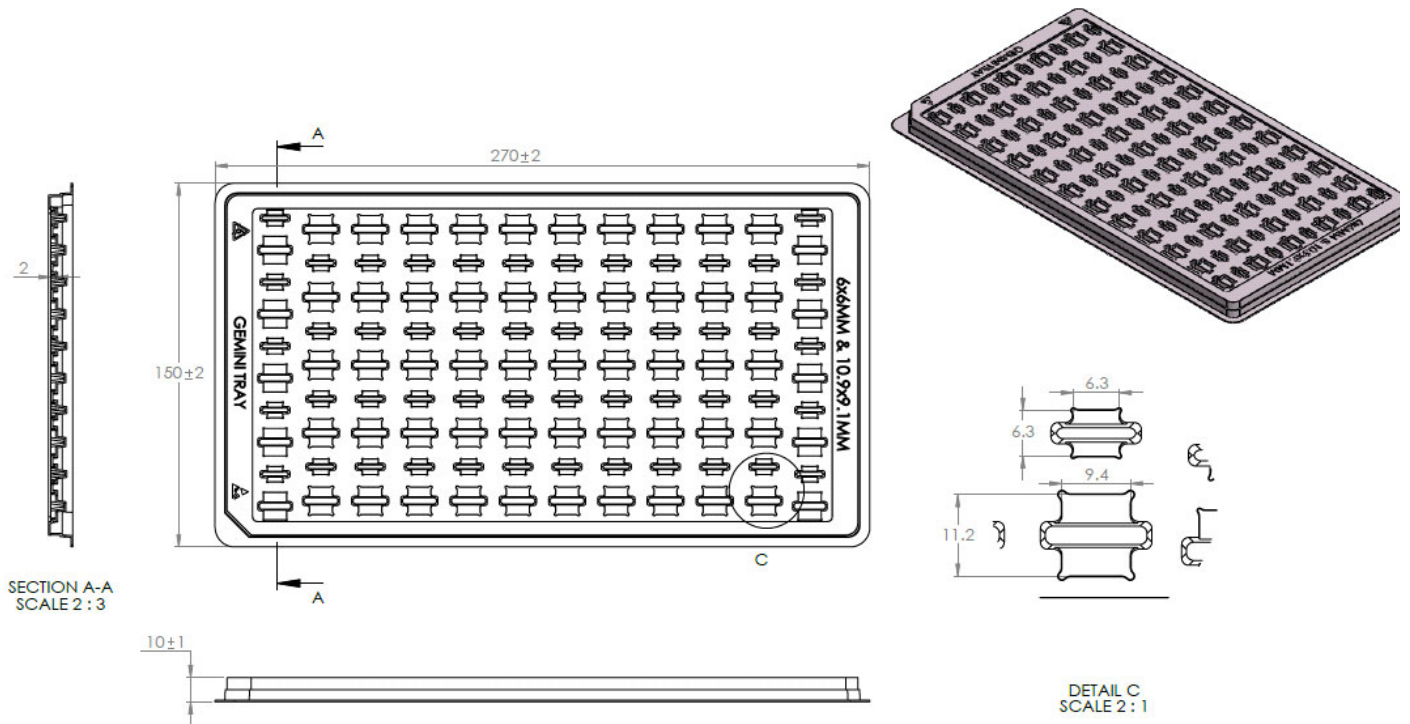

Note that unless otherwise specified:

1. All dimensions are bottom size and in mm.
2. The container must be clear, free from contamination, no fingerprints, and no dimensional prints.
3. No mold release allowed.
4. All radii are formed by vacuum molding and are noncritical.
5. The raw material thickness is 0.7 mm.



- 6.1 Critical dimensions for incoming inspection are identified with a triangle.
- 6.2 Critical-to-function dimensions used for buy-off process are identified with an inspection bubble.

Nozzle Name CN220 and Nozzle Size (Inner Diameter: 2.2 mm; Outer Diameter: 3.6 mm)

