

## AR35-T25E/S Series

### AR35 Through-Hole Series Miniature Programmable Single-Turn Absolute Encoder with Resolution Ranging from 17 Bits to 25 Bits

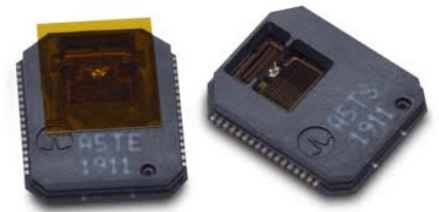

#### Description

The Broadcom<sup>®</sup> AR35-T25 Series programmable reflective absolute through-hole rotary encoders are designed for space-constrained motion control applications.

The AR35-T25 Series encoder is designed with an overall diameter of 35 mm and a maximum axial through-hole of 9.5 mm for through-shaft motors and axial cabling.

The AR35-T25 Series provides the incremental ABI and UVW in differential mode. Both modes come with a recommended temperature range of  $-40^{\circ}\text{C}$  to  $115^{\circ}\text{C}$ , suitable for most industrial applications. Dual-mode operating voltage of 3.3V and 5V are suitable for handheld and portable device applications.

Employing Broadcom-patented Reflective Optical Encoding Theory, the AR35-T25 Series provides high-accuracy with correction, which is unattainable by the magnetic encoder.

#### Features

- Miniature absolute encoder ASIC surface-mount DFN package: 10.9 mm (L) x 9.1 mm (W) x 1.5 mm (H)
- User-programmable resolution ranging from:
  - 17-bit and 25-bit single turn
- User-programmable incremental output (ABI) resolution ranging from 128 to 8192 CPR
- User-programmable commutation signal (UVW) ranging from 2, 3, 4, 5, 12, 30, 32 pole pair
- Differential output for ABI and UVW
- Temperature range of  $-40^{\circ}\text{C}$  to  $115^{\circ}\text{C}$ , suitable for most industrial operations.
- Dual-mode operating voltage of 3.3V and 5V, enabling handheld and portable device applications.
- Selectable Absolute Serial Output Communication Protocol
  - SSI mode
  - ESL mode (Encoder Serial Link)
- RoHS compliance

#### Applications

- Robotic automation and engineering
- Factory automation and drone
- Medical and dentistry, devices and equipment
- High-accuracy portable and handheld devices
- Miniature motor, servo motor, and linear actuator

# Functional Block Diagram

## SSI 3-Wire Communication Protocol Selection

Figure 1: SSI 3-Wire Block Diagram

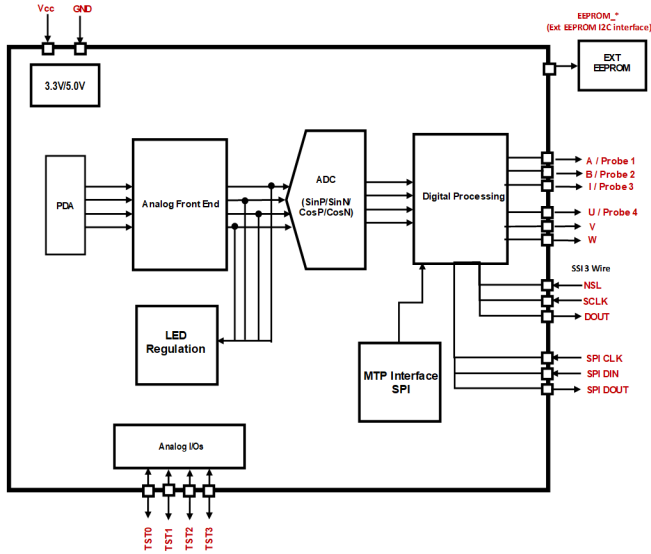

## ESL Communication Protocol Selection

Figure 2: ESL Block Diagram

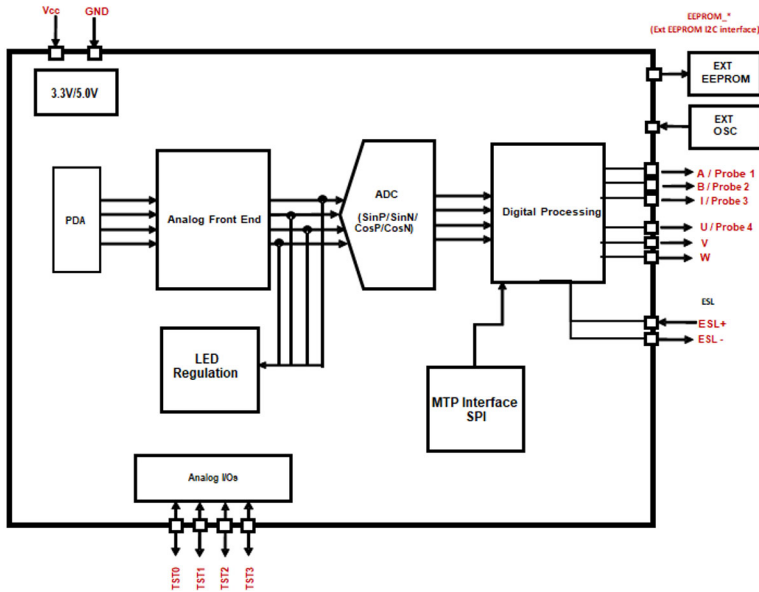

# Mechanical Specifications

## DFN Package Dimensions

Figure 3: Overall Package Dimensions and Pinout

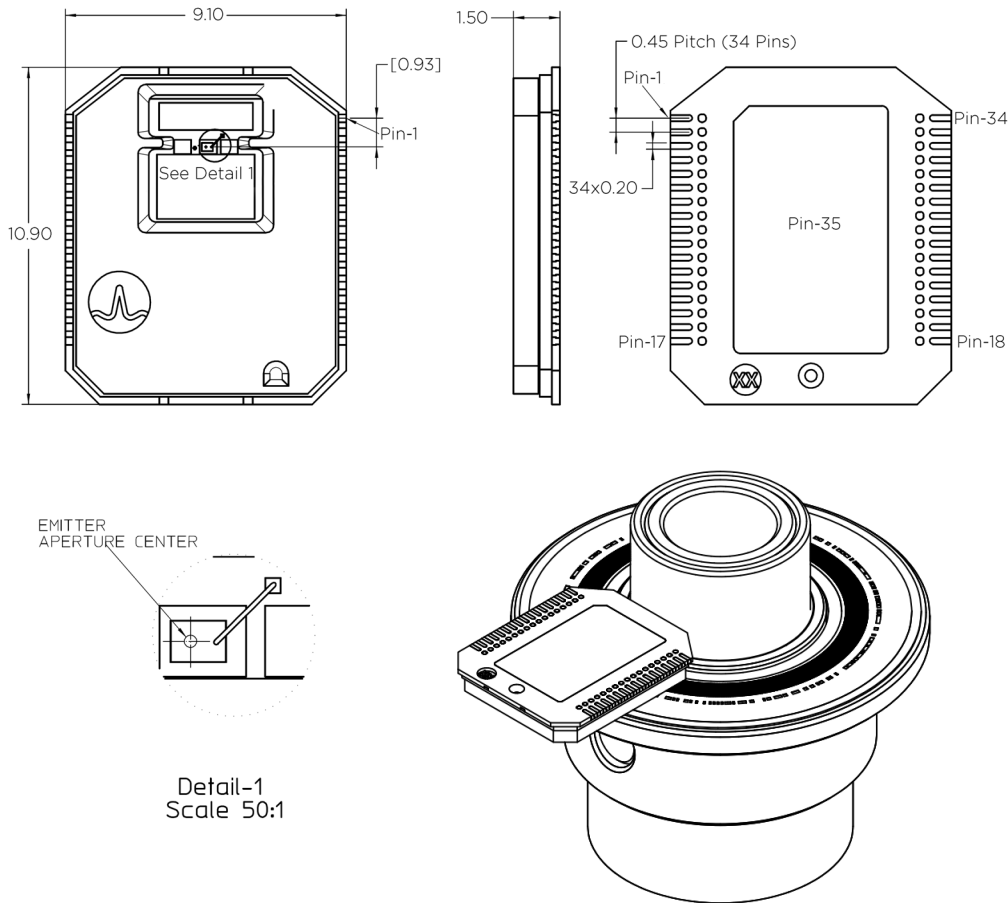

All dimensions are given in mm. Tolerances of form and position according to JEDEC MO-220.

## Package Markings

Figure 4: Product Marking Information

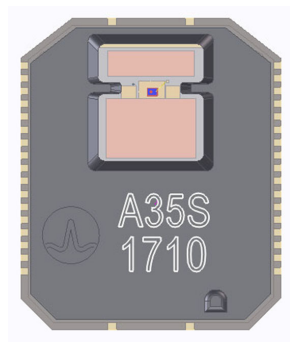

Part Type:

- A5TS/E

Date Code:

- YYWW (Year, Work Week)

# Encoder Mounting

Figure 5: Encoder Mounting Guide

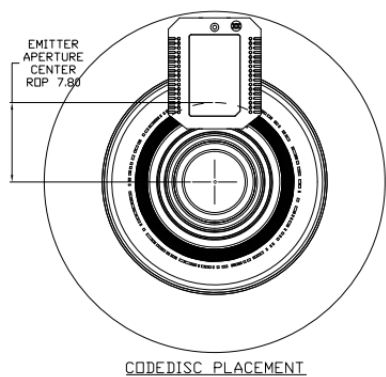
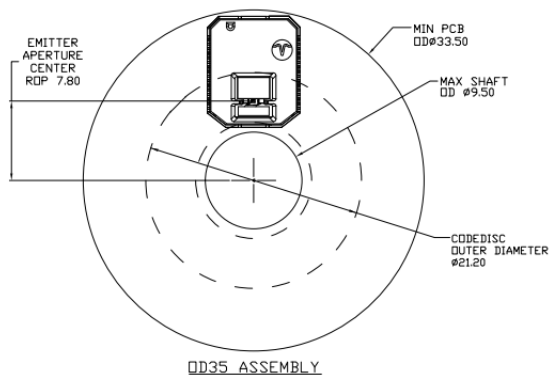
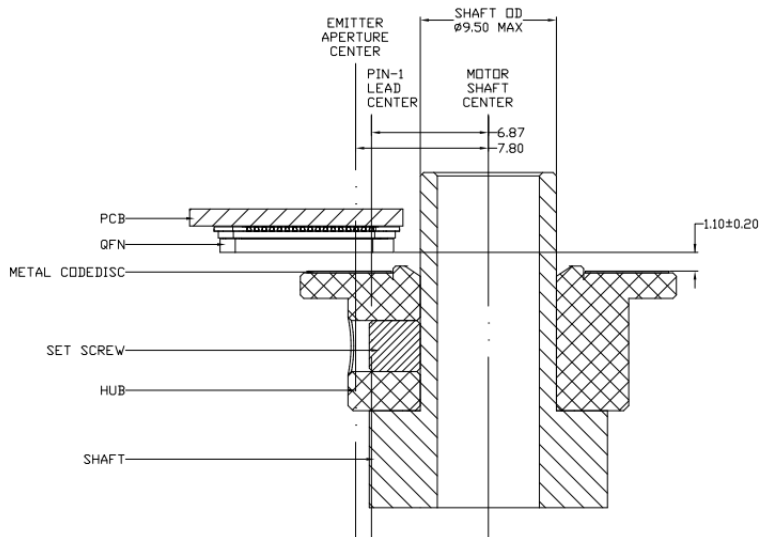

Notes on assembly:

- The assembly of the encoder needs a clean room environment of Class 100k or better.
- The encoder needs to be enclosed with an IP50 rating enclosure.

## Recommended PCB Land Pattern

Figure 6: PCB Land Pattern

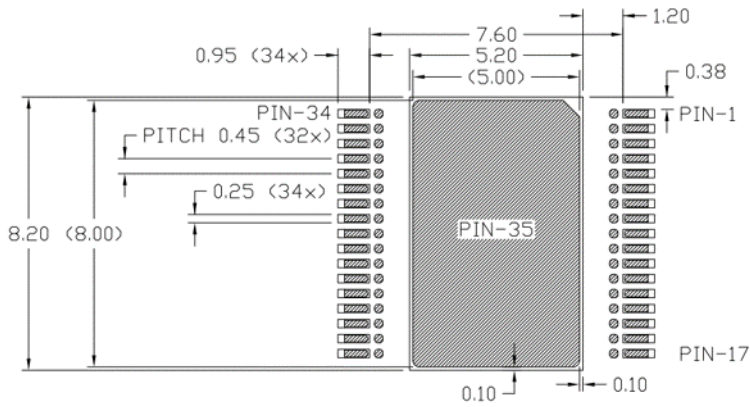
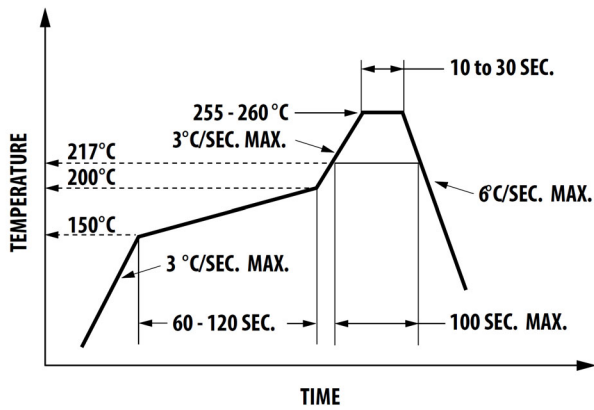

Figure 7: Recommended Pb-Free SMT Reflow Soldering Profile According to JEDEC Pb-Free (J-STD-020D)



## Electrical Specifications

### Recommended Operating Conditions

Parameter	Symbol	Min.	Typical	Max.	Unit	Notes
DC Supply Voltage	$V_{dd}$	+4.5	+5.0	+5.5	V	—
DC Supply Voltage	$V_{dd}$	+3.0	+3.3	+3.6	V	—
Ripple of Supply Voltage	—	—	—	100	mVpp	100 kHz
Output Current per channel	—	—	—	±5	mA	—
Rise Time	$t_r$	—	30	—	ns	$C_L = 50$ pF
Fall Time	$t_f$	—	30	—	ns	$R_L = 1.2$ kΩ
Ambient Temperature	$T_{amb}$	—	+25	—	°C	—
Operational Temperature	$T_A$	-40	+25	+115	°C	—
Storage Temperature	$T_S$	-40	+25	+115	°C	—
Humidity	RH	—	—	85	%	Temp = 40°C
INC Operating Frequency	—	—	—	128	kHz	Velocity (rpm) x CPR/60
Radial Misalignment	—	-200	0	+200	μm	—
Tangential Misalignment	—	-200	0	+200	μm	—
Encoder Shaft Speed	SRPM	—	—	15000	rpm	512 CPR (AR35)

### Recommended Code Wheel Characteristics

Parameter	Symbol	Min.	Typical	Max.	Unit	Notes
Specular Reflectance	$R_f$	60%	—	—	—	Reflective area
		—	—	5%		Non-reflective area

**NOTE:** Characteristics are based on a BRCM qualified code wheel supplier. Refer to BRCM for a qualified reflective code wheel supplier.

### Absolute Maximum Ratings

Parameter	Symbol	Value
Storage Temperature	$T_S$	-40°C to 115°C
Operating Temperature	$T_A$	-40°C to 115°C
Supply Voltage	$V_{dd}$	7V
ESD (HBM), JS-001-2014	—	± 2kV
Moisture Sensitive Level	MSL	3 (Maximum floor life = 168 hours)

## DC Characteristics

The following table shows the DC characteristics over the recommended operating range, typically at 25°C.

Parameter	Symbol	Conditions	Value			Unit	Notes
			Min.	Typ.	Max.		
V <sub>dd</sub> Supply Current	I <sub>dd</sub>	V <sub>dd</sub> = 3.3V/5V	—	70	—	mA	—
Absolute Single Turn Resolution (AR35)	—	—	—	25	—	Bit	—
Incremental Resolution	—	—	—	2 <sup>n</sup>	—	CPR	n= 7,8,9,10,11,12,13

## Encoder Characteristics

Incremental encoder characteristics over the recommended operating condition, at 25°C.

Parameter Type	Parameter	Symbol	Min.	Typ.	Max. <sup>a</sup>	Unit
ABI	Cycle Error	ΔC	—	—	45	°e
	State Error	ΔS	—	—	45	°e
	Index Pulse Width	P <sub>o</sub>	—	90,180, 360	—	°e
Commutation (UVW)	Commutation Accuracy (middle of channel I to channel U)	ΔI	-0.1	—	+0.1	°mechanical
	Commutation Accuracy (Channel U,V and W)	ΔUVW	-0.1	—	+0.1	°mechanical

a. Maximum values represent the encoder performance across the range of recommended mounting tolerance.

Encoder raw accuracy characteristics over the recommended operating condition, at 25°C.

Parameter	Symbol	Min.	Typ.	Max. <sup>a</sup>	Unit
Raw Accuracy (AR35)	—	—	±350	—	Arc-sec

a. Typical values represent the encoder performance with shaft TIR < 10 μm, Φ5.991 through 5.996 mm; CW hub ID = 6.000 through 6.008 mm.

## Encoder Pin Functions

Figure 8: Pinouts from Top View

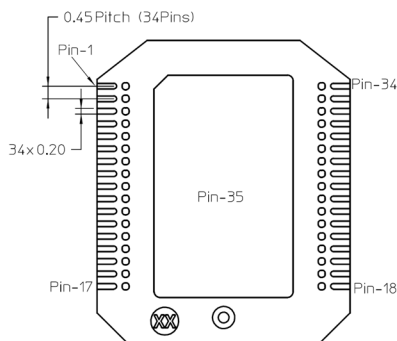

## SSI 3-Wire Option Pinout Configuration

**NOTE:** Pin-35 must be grounded to VSSA, and pin-17 must connect to common GND.

Pin	Name	Function	Pad type	Analog/Digital	Input/ Output
1	CN/TST3	Analog Voltage Output NCOS	5V/3.3V pads	Analog	I/O
2	CP/TST2	Analog Voltage Output PCOS	5V/3.3V pads	Analog	I/O
3	SN/TST1	Analog Voltage Output NSIN	5V/3.3V pads	Analog	I/O
4	SP/TST0	Analog Voltage Output PSIN	5V/3.3V pads	Analog	I/O
5	SPI DOUT	SPI Data Output	3.3V/5V (VDDPAD)	Digital	Output
6	SPI DIN	SPI Data Input	3.3V/5V (VDDPAD)	Digital	Input
7	SPI CLK	SPI Clock	3.3V/5V (VDDPAD)	Digital	Input
8	VDD	Digital Supply Voltage	3.3V/5V (VDDPAD)	Digital	Power
9	VSS	Digital GND	Digital ground	Digital ground	Ground
10	+SSI DOUT	SSI Data Output (+)	3.3V/5V (VDDPAD)	Digital	I/O
11	-SSI DOUT	SSI Data Output (-)	3.3V/5V (VDDPAD)	Digital	I/O
12	+SSI NSL	SSI Input (+)	3.3V/5V (VDDPAD)	Digital	I/O
13	-SSI NSL	SSI Input (-)	3.3V/5V (VDDPAD)	Digital	Input
14	+SSI SCL	SSI Clock (+)	3.3V/5V (VDDPAD)	Digital	Input
15	-SSI SCL	SSI Clock (-)	3.3V/5V (VDDPAD)	Digital	Input
16		—			
17	ESL SEL	Protocol Selection	Selection (GND)	Ground	Ground
18	EEPROM SCL	EXT EEPROM Clock	3.3V/5V (VDDPAD)	Digital	I/O
19	EEPROM SDA	EXT EEPROM Data	3.3V 5V (VDDPAD)	Digital	I/O
20	EEPROM WP	EXT EEPROM Write Protect	3.3V/5V (VDDPAD)	Digital	Output
21	-A	Incremental -A Output	3.3V/5V (VDDPAD)	Digital	Output
22	+A/PROBE1	Incremental +A Output	3.3V/5V (VDDPAD)	Digital	Output
23	-B	Incremental -B Output	3.3V/5V (VDDPAD)	Digital	Output
24	+B/PROBE2	Incremental +B Output	3.3V/5V (VDDPAD)	Digital	Output
25	-I	Incremental -Index Output	3.3V/5V (VDDPAD)	Digital	Output
26	+I/PROBE3	Incremental +Index Output	3.3V/5V (VDDPAD)	Digital	Output
27	VSSA	Analog GND	Analog ground	Analog ground	Ground
28	VDDA	Analog Supply Voltage	3.3V/5V (VDDPAD)	Analog	Power
29	-U	Incremental -U Output	3.3V/5V (VDDPAD)	Digital	Output
30	+U/PROBE4	Incremental +U Output	3.3V/5V (VDDPAD)	Digital	Output
31	-V	Incremental -V Output	3.3V/5V (VDDPAD)	Digital	Output
32	+V	Incremental +V Output	3.3V/5V (VDDPAD)	Digital	Output
33	-W	Incremental -W Output	3.3V/5V (VDDPAD)	Digital	Output
34	+W	Incremental +W Output	3.3V/5V (VDDPAD)	Digital	Output
35	Common GND (VSSA)	Ground to VSSA	Analog ground	Analog ground	Ground



## ESL Option Pinout Configuration

**NOTE:** Pin 35 must be grounded to VSSA, and pin 17 must connect to VDD (5V/3.3V).

Pin	Name	Function	Pad type	Analog/Digital	Input/Output
1	CN/TST3	Analog Voltage Output NCOS	5V/3.3V pads	Analog	I/O
2	CP/TST2	Analog Voltage Output PCOS	5V/3.3V pads	Analog	I/O
3	SN/TST1	Analog Voltage Output NSIN	5V/3.3V pads	Analog	I/O
4	SP/TST0	Analog Voltage Output PSIN	5V/3.3V pads	Analog	I/O
5		—			
6		—			
7		—			
8	VDD	Digital Supply Voltage	3.3V/5V (VDDPAD)	Digital	Power
9	VSS	Digital GND	Digital ground	Digital ground	Ground
10	+ESL	ESL Data Output (+)	3.3V/5V (VDDPAD)	Digital	I/O
11	-ESL	ESL Data Output (-)	3.3V/5V (VDDPAD)	Digital	I/O
12		—			
13		—			
14		—			
15		—			
16	OSC_EXT	External Oscillator <sup>a</sup>	3.3V/5V (VDDPAD)	Digital	Input
17	ESL_SEL	Protocol Selection	Selection (VDD)	Digital	Power
18	EEPROM_SCL	EXT EEPROM Clock	3.3V/5V (VDDPAD)	Digital	I/O
19	EEPROM_SDA	EXT EEPROM Data	3.3V/5V (VDDPAD)	Digital	I/O
20	EEPROM_WP	EXT EEPROM Write Protect	3.3V/5V (VDDPAD)	Digital	Output
21	-A	Incremental -A Output	3.3V/5V (VDDPAD)	Digital	Output
22	+A/PROBE1	Incremental +A Output	3.3V/5V (VDDPAD)	Digital	Output
23	-B	Incremental -B Output	3.3V/5V (VDDPAD)	Digital	Output
24	+B/PROBE2	Incremental +B Output	3.3V/5V (VDDPAD)	Digital	Output
25	-I	Incremental -Index Output	3.3V/5V (VDDPAD)	Digital	Output
26	+I/PROBE3	Incremental +Index Output	3.3V/5V (VDDPAD)	Digital	Output
27	VSSA	Analog GND	Analog ground	Analog ground	Ground
28	VDDA	Analog Supply Voltage	3.3V/5V (VDDPAD)	Analog	Power
29	-U	Incremental -U Output	3.3V/5V (VDDPAD)	Digital	Output
30	+U/PROBE4	Incremental +U Output	3.3V/5V (VDDPAD)	Digital	Output
31	-V	Incremental -V Output	3.3V/5V (VDDPAD)	Digital	Output
32	+V	Incremental +V Output	3.3V/5V (VDDPAD)	Digital	Output
33	-W	Incremental -W Output	3.3V/5V (VDDPAD)	Digital	Output
34	+W	Incremental +W Output	3.3V/5V (VDDPAD)	Digital	Output
35	Common GND (VSSA)	Ground to VSSA	Analog ground	Analog ground	Ground

a. 50 Mhz (10 ppm) oscillator input is required for ESL configuration

# Communication Protocol

## SSI 3-Wire

Figure 9: SSI 3-Wire Timing Diagram

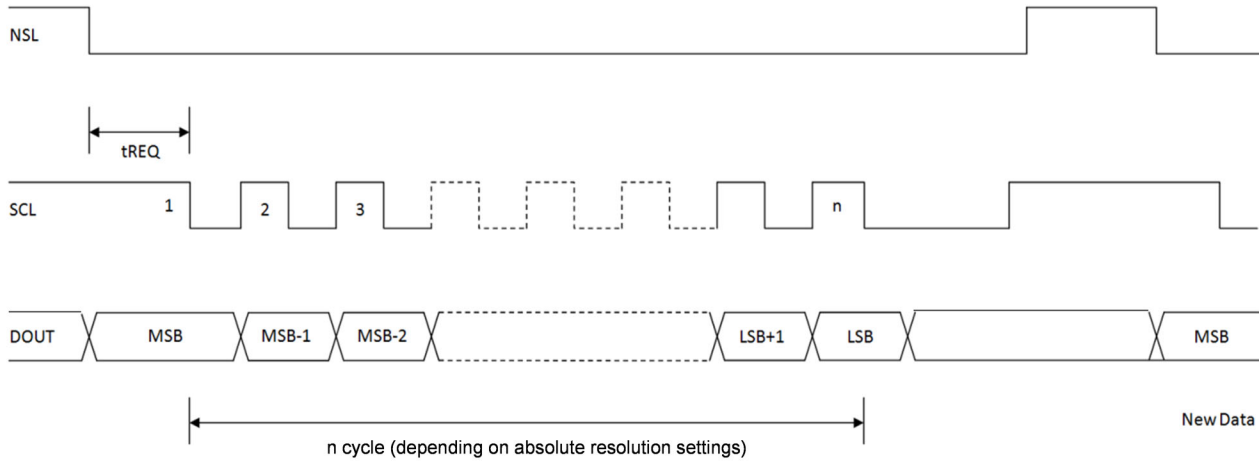

**NOTE:**

- NSL toggle from high to low to start request position data.
- SCL maximum frequency is 10 MHz.
- $t_{REQ} = 10 \mu s$  is the time of data request processing.

Figure 10: AR35 SSI 3-Wire Format Output

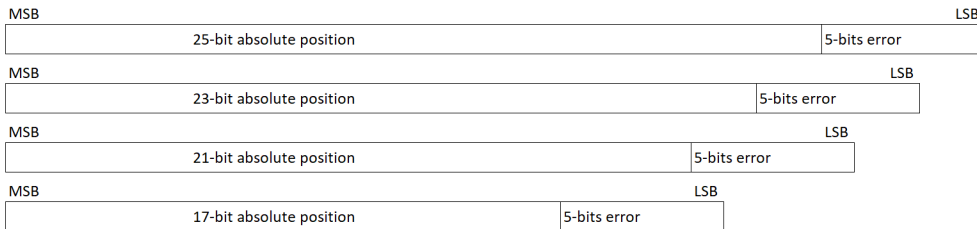
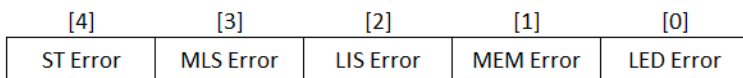

Figure 11: Alarm Bit Definition



**NOTE:** Refer to application notes for more detail.

## ESL

Figure 12: General Transmission Frames Format on Half-Duplex Line

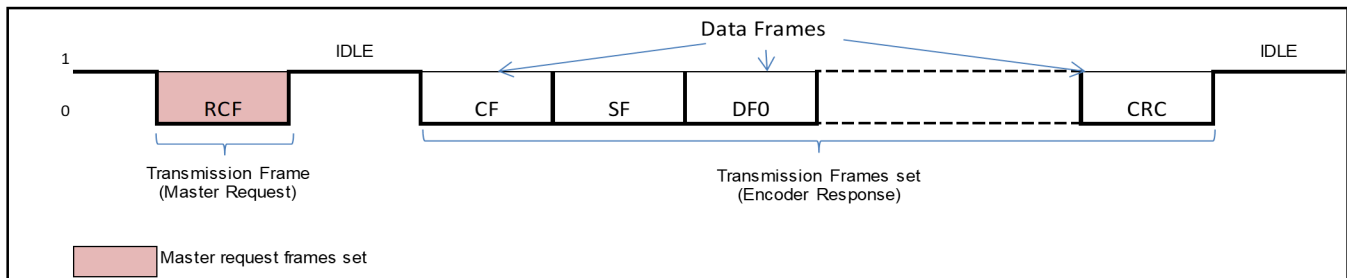

**Start of transmission frames set:** Upon detected the first logic of low state 0 on the transmission line after idling state, and if the following 3 bit conforms to command identifier, the encoder will acknowledge as a valid Request Command Frame (RCF), indicating the start of transmission frame set, else, it will continue to search for next available logic of low state 0.

**End of transmission frames set:** After the Request Command Frame is detected, if there is no Start Bit after the End Bit of the last frame read and no subsequent frame detected, end of transmission frame set is concluded.

**Idle state:** Idle state means a space between each transmission frames set and subsequent transmission frames. At idling state, logic of output in transmission line is kept to high state 1.

## Encoder Data Read Out Frame Sets Format and Timing

Figure 13: Encoder Data Read Out Frames Set

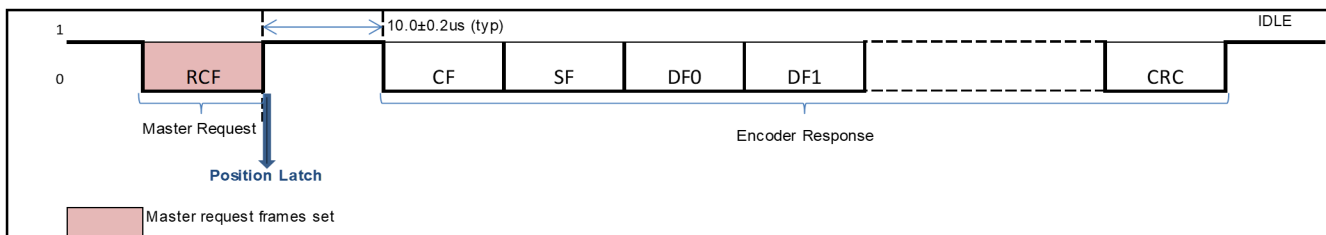

Upon the master issue a RCF frame request, after  $10.0 \mu\text{s}$  (typ.), the encoder will respond with encoder data frames set with the following content:

1. CF: Corresponds to the RCF issued from Master
2. SF: Status frame
3. DF0 through DF7: Data frames
4. CRC: Cyclic Redundancy Check frame

The encoder position calculation is completed within  $10.0 \mu\text{s}$  (typ.) after the end bit of the Master RCF.

The encoder response data frames set formats are dependent on the requested operation by the Master RCF, see [Data Frames Content with Respective Command ID](#).

## Data Frames Content with Respective Command ID

Command ID	DF0	DF1	DF2	DF3	DF4	DF5	DF6	DF7
Command ID 4	ALMC <sup>a</sup>	ABS0 <sup>b</sup>	ABS1	ABS2	ABS3	—	—	—
Command ID 6	ABS0	ABS1	ABS2	ABS3	—	—	—	—
Command ID 8	ENID <sup>c</sup>	—	—	—	—	—	—	—
Command ID A	ALMC	—	—	—	—	—	—	—
Command ID B	ALMC	ABS0	ABS1	ABS2	ABS3	—	—	—
Command ID C	ALMC	ABS0	ABS1	ABS2	ABS3	—	—	—

- ALMC: Encoder Alarm Flags.
- ABS<sub>n</sub>: Single-turn counts, LSB of the single-turn counts are located in ABS0 and MSB of the counts data are located in ABS3. Combining ABS0 through ABS3 will provide a total to 32-bits of single-turn data. For the single-turn 25-bits encoder option, the 7 MSB of ABS3 is fixed to 0, hence giving a total 25-bits of single turn-data.
- ENID: Encoder single-turn bits identification. For the single-turn 25-bits encoder option, ENID is fixed as 19h.

## Memory Data Read Out Frames Set Format and Timing

Figure 14: Memory Data Read Out Frames Set

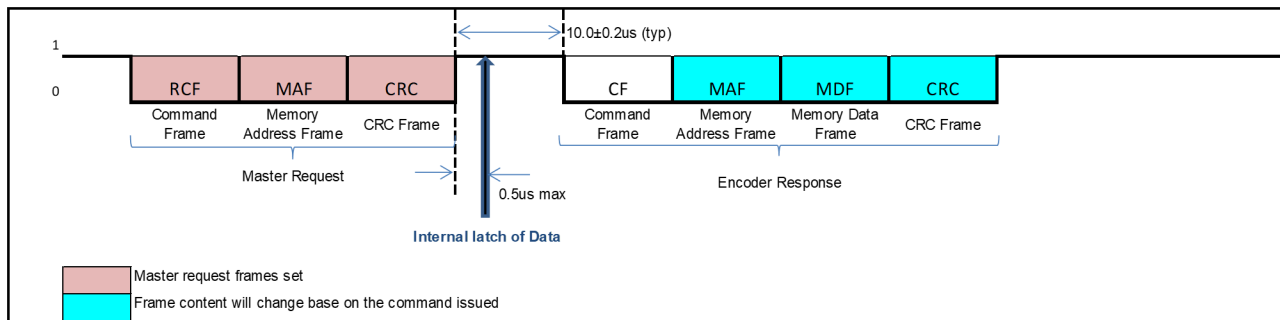

Content of transmission frames:

- RCF: Request Command Frame (RCF) from Master.
- CF: Corresponds to the RCF issued from Master.
- MAF: Memory Address Frame indicates the memory location to read.
- MDF: Memory Data Frame contains the data read from memory.
- CRC: Cyclic Redundancy Check frame.

## Memory Data Write Frames Set Format and Timing

Figure 15: Memory Data Write Frames Set

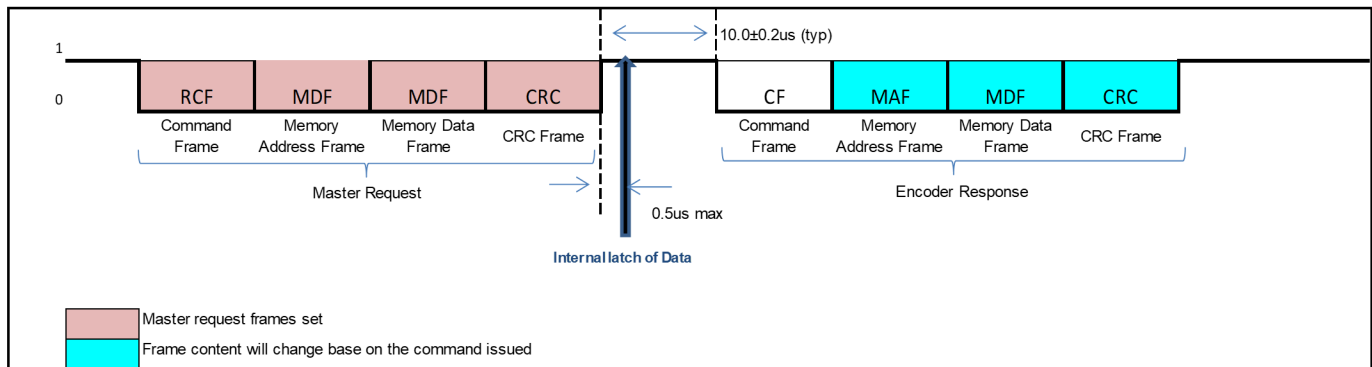

Content of transmission frames:

1. RCF: Request Command Frame (RCF) from Master.
2. CF: Corresponds to the RCF issued from Master.
3. MAF: Memory Address Frame indicates the memory location to read.
4. MDF: Memory Data Frame contains the data read from memory.
5. CRC: Cyclic Redundancy Check (CRC) frame.

## Configurations and Signal Output

### Customer Encoder Configuration Settings

Page (Hex)	Address	Bit (s)	Name	Settings	Output	Default (Hex)		
0x08	0x00	0–7	Register Unlock	Unlock (Write 0xAB)	Unlock register	8'h00		
0x0E	0x09	7	EEPROM Disable	0	Enable EEPROM	8'h00		
				1	Disable EEPROM			
		5	CW Direction	0	Count UP (CCW)			
				1	Count UP (CW)			
	0x0A	5–7	UVW Setting [2:0]	000	2 pole-pairs	8'hC0		
				001	3 pole-pairs			
				010	4 pole-pairs			
				011	5 pole-pairs			
				100	12 pole-pairs			
				101	30 pole-pairs			
				110	32 pole-pairs			
				111	32 pole-pairs			
				3–4	I-width Setting		00	90 edeg
							01	180 edeg
							10	360 edeg
							11	90 edeg
		0–2	CPR Setting	000	8192			
001				4096				
010				2048				
011				1024				
100	512							
101	256							
110	128							
111	128							
0x0B	0–1	Abs Resolution	Bit: 00	17 Bit	8'h3F			

## Customer Reserved Zero Offset and Calibration Registers

Page	Address	Bit (s)	Name	Description
0x0E	0x09	0-5	Customer Configuration 1	User Programmable
	0x0A	0-7	Customer Configuration 2	User Programmable
	0x0C	0-7	Zero Reset 0	Zero Reset Position [8:1]
	0x0D	0-7	Zero Reset 1	Zero Reset Position [16:9]
	0x0E	0-7	Zero Reset 2	Zero Reset Position [24:17]
	0x14	7	Alarm Reset	Alarm Clear

## Incremental Output Format

Figure 16: ABI Signals Based on Code Wheel Direction Setting 0

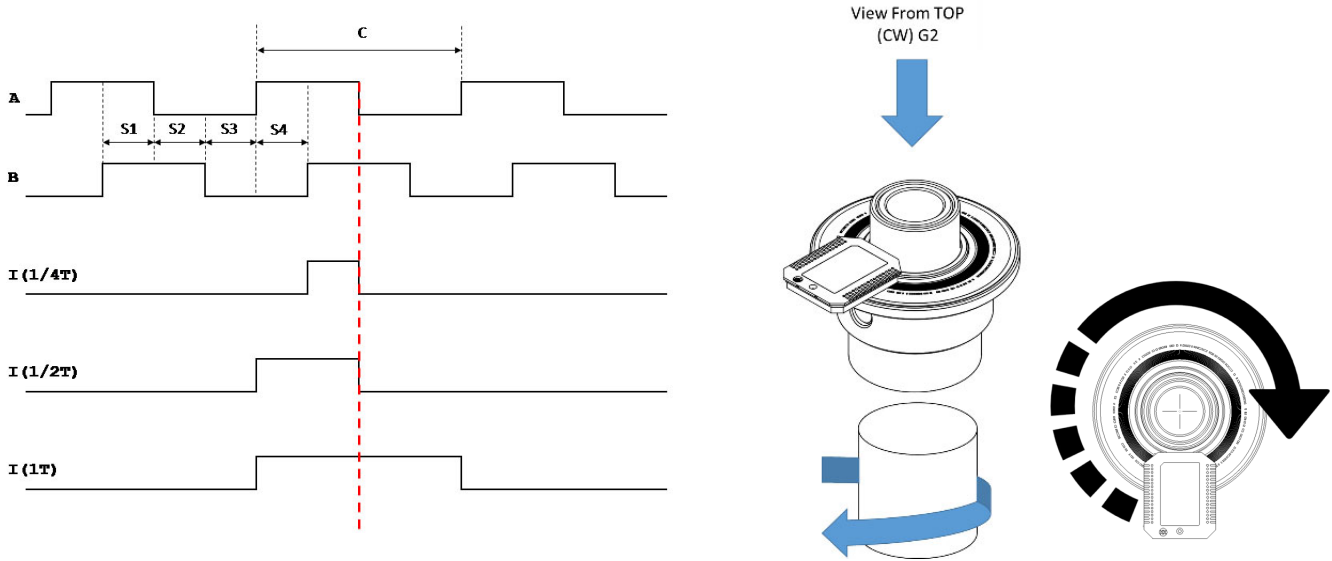
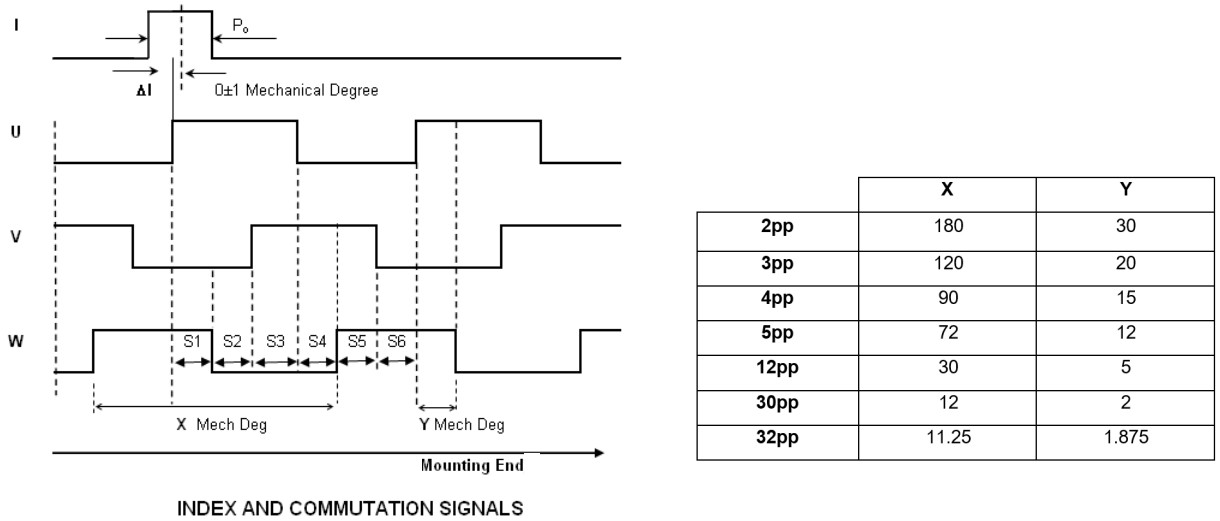
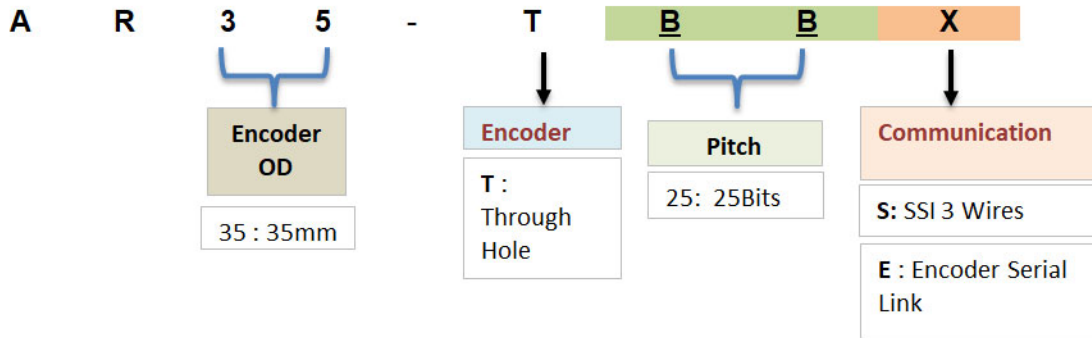

Figure 17: UVW Signals Based on Code Wheel Direction Setting 0



# Ordering Information

Figure 18: Encoder Ordering Information



## Calibration Kit

- Ordering Part Number: A25E-0030
- Description: Linear and Through Hole, AR35 Calibration Kit

Figure 19: Code Wheel Ordering Information

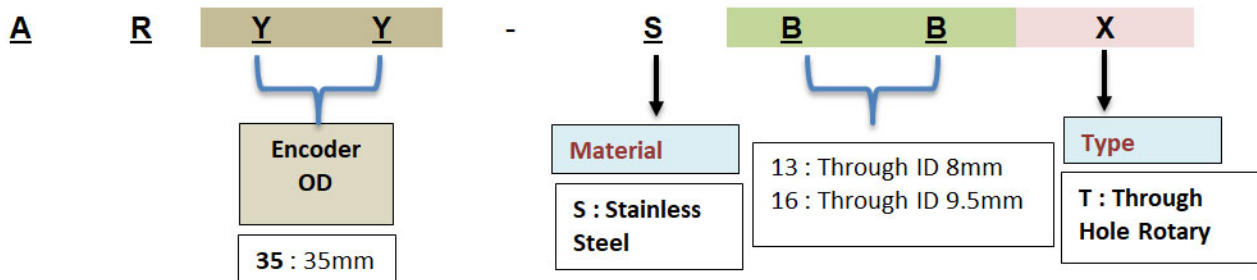



## Packaging

- Encoder Packaging Information (Tray): 60 units per tray
- Code Wheel Packaging Information (Tray): 48 units per tray

**Figure 20: Encoder Tray Packaging Information**

