



ARR-NF-NF-B-8

N Jack to N Jack Sealed Bulkhead Lightning Arrester

The ARR-NF-NF-B-8 is an N jack (female socket) to N jack IP67-rated sealed bulkhead lightning arrester, which includes a silicone gasket, washer, and hex nut for installation as well as an optional aluminum mounting bracket. Linx lightning arresters offer protection from overload in electronic circuits by diverting excessive current generated by thunderstorms directly to ground.

Operating from 0 Hz to 8 GHz, the ARR-NF-NF-B-8 provides superior performance in a gas discharge DC pass-through type lightning arrester. Additionally, all Linx lightning arresters are tested to meet requirements for corrosion resistance, vibration, mechanical and thermal shock.

FEATURES

- 0 Hz to 8 GHz operation
- Gas discharge DC pass-through type lightning arrester
- N jack (female socket) connection
 - Gold plated brass center contact
- Brass hex nut, washer, silicone gasket and optional mounting bracket provided
- IP67 rated

APPLICATIONS

- Outdoor Networks
- Low-power, wide-area (LPWA)
 - Helium™, LoRaWan®, Sigfox®, Wifi HaLow™
- Private Cellular Networks
 - Citizens Broadband Radio Service (CBRS)
- Public Safety
- Internet of Things (IoT)
- C-V2I (Cellular Vehicle to Infrastructure)
- Cellular IoT
 - LTE-M (Cat-M1), NB-IoT
- Cellular
 - 5G/4G LTE/3G/2G
- WiFi 6E/6/5/4, 802.11b/g

ORDERING INFORMATION

Part Number	Description
ARR-NF-NF-B-8	N jack to N jack bulkhead lightning arrester with silicone gasket, 5/8 in. washer, 5/8-24 hex nut and optional mounting flange

Available from Linx Technologies and select distributors and representatives.

PERFORMANCE

Table 1 shows the electrical specifications, insertion loss and VSWR values for the ARR-NF-NF-B-8 lightning arrester at commonly used frequencies.

Insertion loss is the loss of signal power (gain) resulting from the insertion of a device in a transmission line. VSWR describes how efficiently power is transmitted through the lightning arrester. A lower VSWR value indicates better performance at a given frequency.

ELECTRICAL SPECIFICATIONS

Band	Low-Band Cellular/ ISM/LPWA	Midband Cellular/ GNSS	ISM	WiFi 6E/6/5/4
Frequency Range	400 MHz to 960 MHz	1.1 GHz to 5 GHz	2.4 GHz	5 GHz to 7.125 GHz
Insertion Loss (dB max)	0.06	0.14	0.08	0.26
VSWR (max)	1.0	1.2	1.1	1.2
Impedance	50 Ω			
Frequency Range	0 Hz to 8 GHz			
Input Power	90W/CW @ 30 MHz 9W/CW @ 3 GHz			
Surge Current	10 kA (wave 8/20 μ s)			
Turn-on Voltage	300 V \pm 20%			
Insulation Resistance	\geq 1 G Ω @100 VDC			
Gas Discharge Tube Lifespan	5 years, in service*			

*All gas discharge tube type arresters require replacement after 5 years of service to ensure proper function and protection of electronics.

MECHANICAL SPECIFICATIONS

ARR-NF-NF-B-8	
Mounting Type	Sealed Bulkhead Mount
Fastening Type	5/8"-24UNEF Threaded Coupling
Interface	MIL-STD-348A
Recommended Torque	0.85 N m (7.5 ft lbs)
Coupling Nut Retention	100 lbs. min.
Connector Durability	500 cycles min.
Weight	88.5 g (3.12 oz)

ENVIRONMENTAL SPECIFICATIONS

MIL-STD/Method/Test Condition	
Corrosion (Salt spray)	MIL-STD-202 Method 101 test condition B
Thermal Shock	MIL-STD-202 Method 107 test condition B
Vibration	MIL-STD-202 Method 204 test condition B
Mechanical Shock	MIL-STD-202 Method 213 test condition I
Temperature Range	-55 $^{\circ}$ C to +105 $^{\circ}$ C
Environmental Compliance	RoHS, REACH

PRODUCT DIMENSIONS

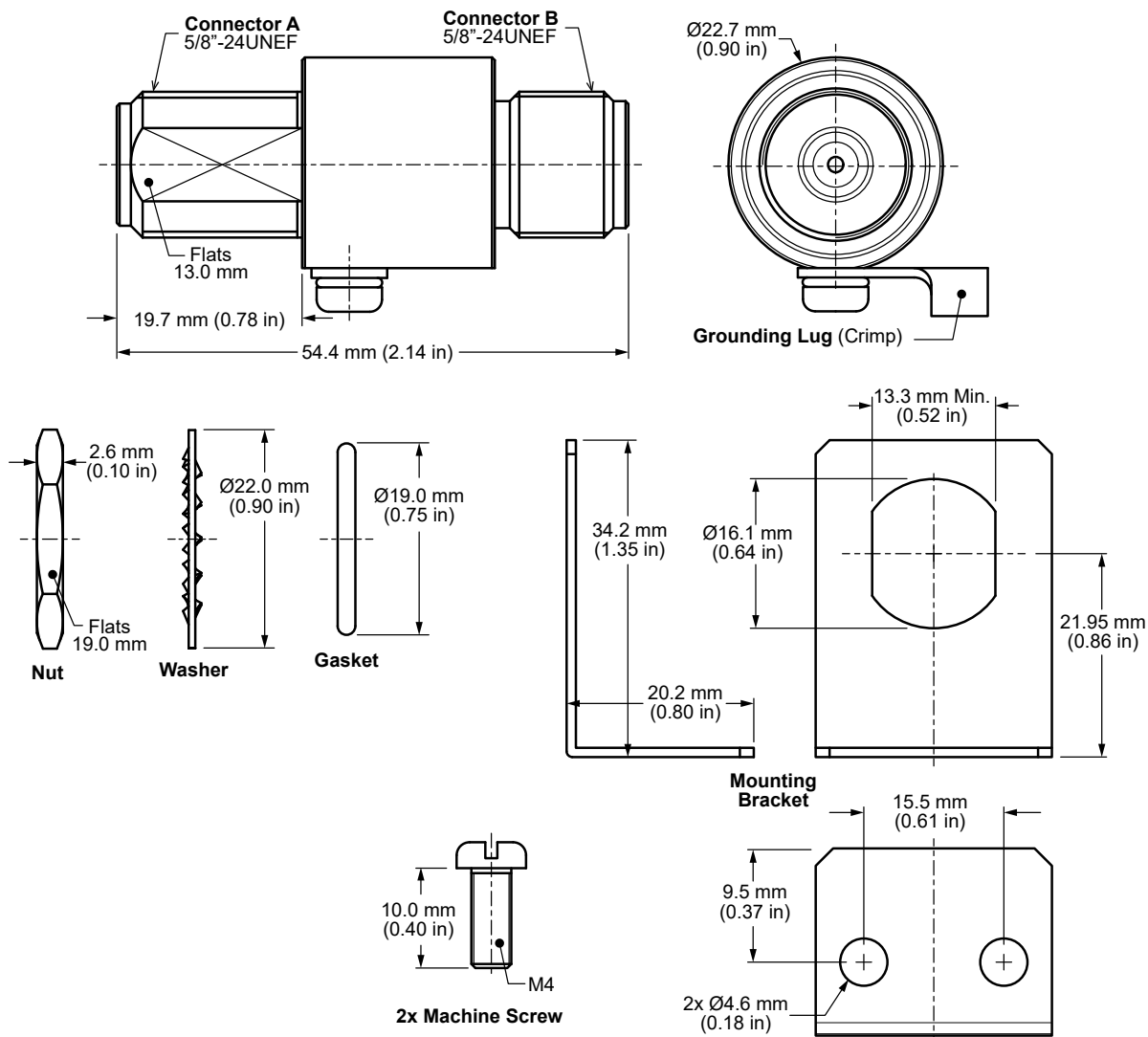

LIGHTNING ARRESTER COMPONENTS

ARR-NF-NF-B-8	Connector A N jack (female socket) Sealed Bulkhead		Connector B N jack (female socket)	
	Material	Finish	Material	Finish
Connector Part	Brass	Nickel	Brass	Nickel
Body	Brass	Nickel	Brass	Nickel
Center Contact (socket)	Brass	Gold	Brass	Gold
Insulator	PTFE	-	PTFE	-
Gasket	Silicone	-	-	-
Washer	Brass	Nickel	-	-
Hex Nut	Brass	Nickel	-	-
Mounting Bracket	Aluminum	-	-	-
Machine Screws (2x)	Iron	Nickel	-	-

RECOMMENDED INSTALLATION

The ARR-NF-NF-B-8 lightning arrester must be coupled to an appropriate ground using the provided crimp-type ground terminal and AWG 18, or larger, stranded grounding wire. Failure to properly ground the lightning arrester will impede the ability of the arrester to protect electronic equipment.

The ARR-NF-NF-B-8 lightning arrester connects inline and can remain free-hanging or mounted through a bulkhead using the provided gasket, washer and nut. The maximum bulkhead thickness = 6.2 mm (0.24 in) and the nut should be tightened to a torque setting of 5 in/lbs max. Mounting is also possible using the provided mounting bracket and two M4 x 10 machine screws. The recommended enclosure mounting dimensions for the ARR-NF-NF-B-8 are shown in Figure 2.

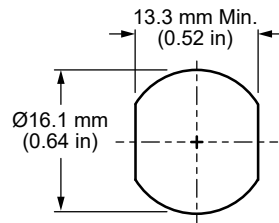

Figure 2. Recommended Enclosure Mounting Dimensions

PACKAGING INFORMATION

The ARR-NF-NF-B-8 lightning arrester is packaged in a plastic bag and placed in an individual carton with the mounting hardware which is sealed in a separate plastic bag. Distribution channels may offer alternative packaging options.

CONNECTOR & ADAPTER DEFINITIONS AND USEFUL FORMULAS

VSWR - Voltage Standing Wave Ratio. VSWR is a unitless ratio that describes how efficiently power is transmitted through the connector. A lower VSWR value indicates better performance at a given frequency. VSWR is easily derived from Return Loss.

$$VSWR = \frac{10^{\left[\frac{\text{Return Loss}}{20}\right]} + 1}{10^{\left[\frac{\text{Return Loss}}{20}\right]} - 1}$$

INSERTION LOSS

The loss of signal power (gain) resulting from the insertion of a device in a transmission line. Insertion loss can be derived from the power transmitted to the load before the insertion of the component P_T and the power transmitted to the load after the insertion of the component P_R .

$$\text{Insertion Loss (dB)} = 10 \log_{10} \frac{P_T}{P_R}$$