

# 1. SPECIFICATION

ART-35150-1

	ITEM	UNIT	SPECIFICATIONS	CONDITION
01	<b>Dimension</b> 尺寸	mm	$\Phi$ 35	Refer to attached drawing in details.
02	<b>Input power</b> 輸入功率	mW	10	White noise is applied for 96 hours.
03	<b>Max. Input power</b> 額定輸入最大功率	mW	Max. 20	at room temperature for 60s on and 120s off for 10 cycles.
04	<b>Impedance</b> 交流阻抗	$\Omega$	150 $\pm$ 15%	at 1KHz /1V.
05	<b>S.P.L</b> 音壓位準 <b>Sound pressure level</b>	dB	96 $\pm$ 3	at 1KHz 60mV /1mW with IEC318 coupler.
07	<b>Frequency range</b> 有效頻寬	Hz	300~3.4K	
08	<b>T.H.D</b> 總諧波失真 <b>Total Harmonics Distortion</b>	%	Max. 5	at 1KHz 60mV / Input power.

REV NO.	REVISION NOTE	APPROVAL	DATE
---------	---------------	----------	------

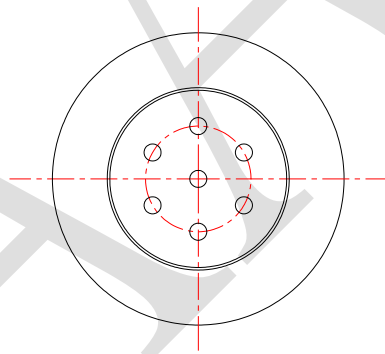
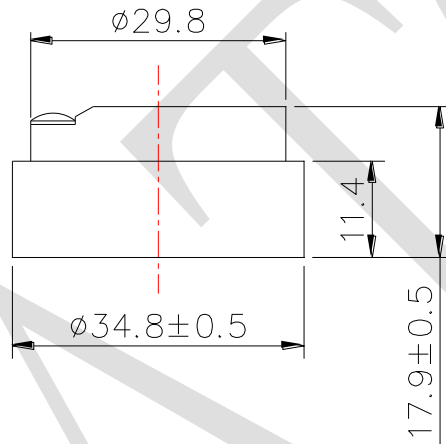
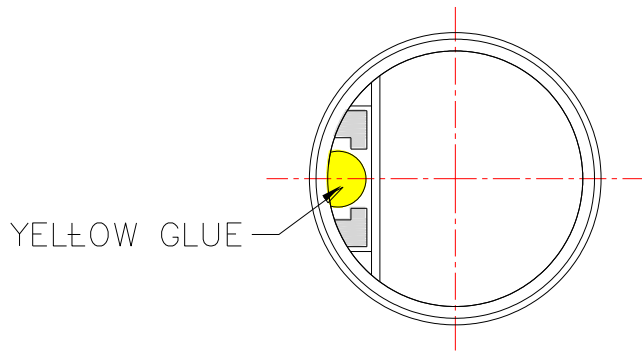

RoHS

TITLE: <i>DYNAMIC RECEIVER</i>		DRAWN: <b>Zack</b>	2017/11/21	SCALE: 2:1	SHEET: 1:1
PART NO. <i>ART-35150-1</i>	1	DESIGNED: <i>R&amp;D OF AAT</i>	UNITS: <i>mm</i>		
DWG NO. <i>UGRP35150-01-02</i>		CHECKED:	TOLERANCE $\pm 0.5$		
REV		APPROVAL:	UNLESS OTHERWISE SPECIFIED: ONE PLACE DECIMAL $\pm$ *** TWO PLACE DECIMAL $\pm$ *** THREE PLACE DECIMAL $\pm$ ***		
		MATERIAL: <i>ABS</i>			



**ADVANCED ACOUSTIC TECHNOLOGY CORPORATION**