

# ARX3A0 - CSP35



## ARX3A0 - CSP35 Evaluation Board User's Manual

ON Semiconductor®

[www.onsemi.com](http://www.onsemi.com)

### Evaluation Board Overview

The evaluation boards are designed to demonstrate the features of ON Semiconductor's image sensors products. This headboard is intended to plug directly into the Demo3 system. Test points and jumpers on the board provide access to the clock, I/Os and other miscellaneous signals.

### Features

- Clock Input
  - ◆ Default – 27 MHz Crystal Oscillator
  - ◆ Optional Demo3 Controlled MClk
- Two Wire Serial Interface
  - ◆ Selectable Base Address
- 2 Lane MIPI Interface
- RoHS Compliant

## EVAL BOARD USER'S MANUAL



Figure 1. ARX3A0 Evaluation Board

### Block Diagram

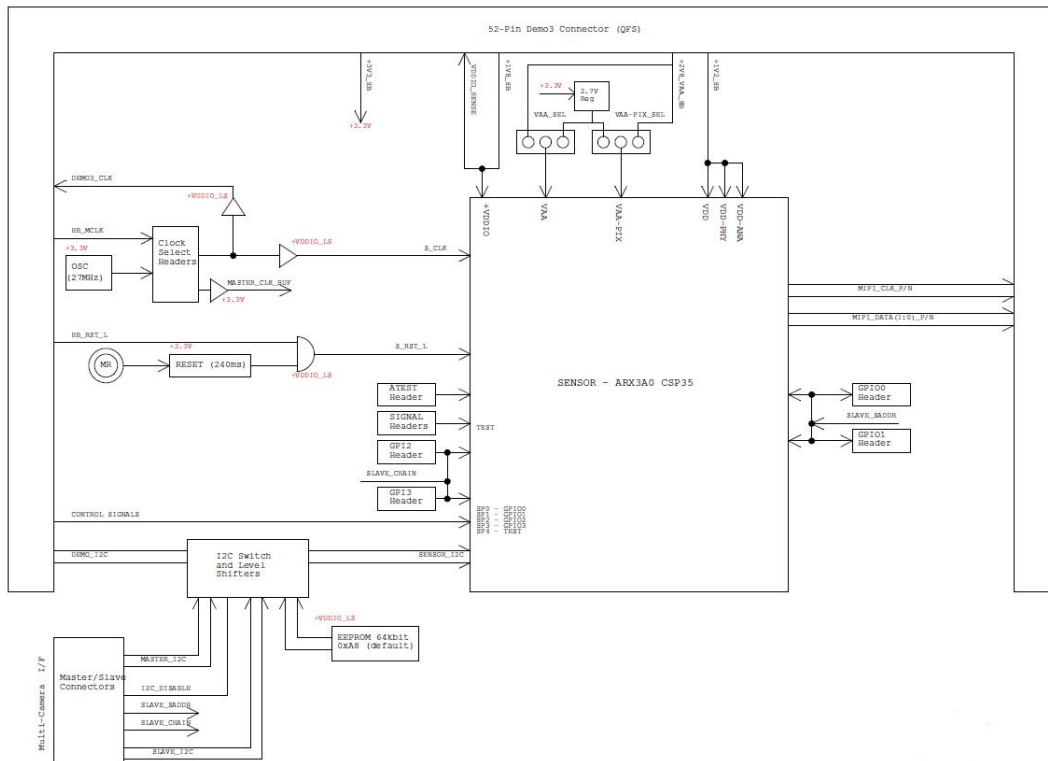

Figure 2. Block Diagram of ARX3A0 Evaluation Board

# ARX3A0 – CSP35

## Top View

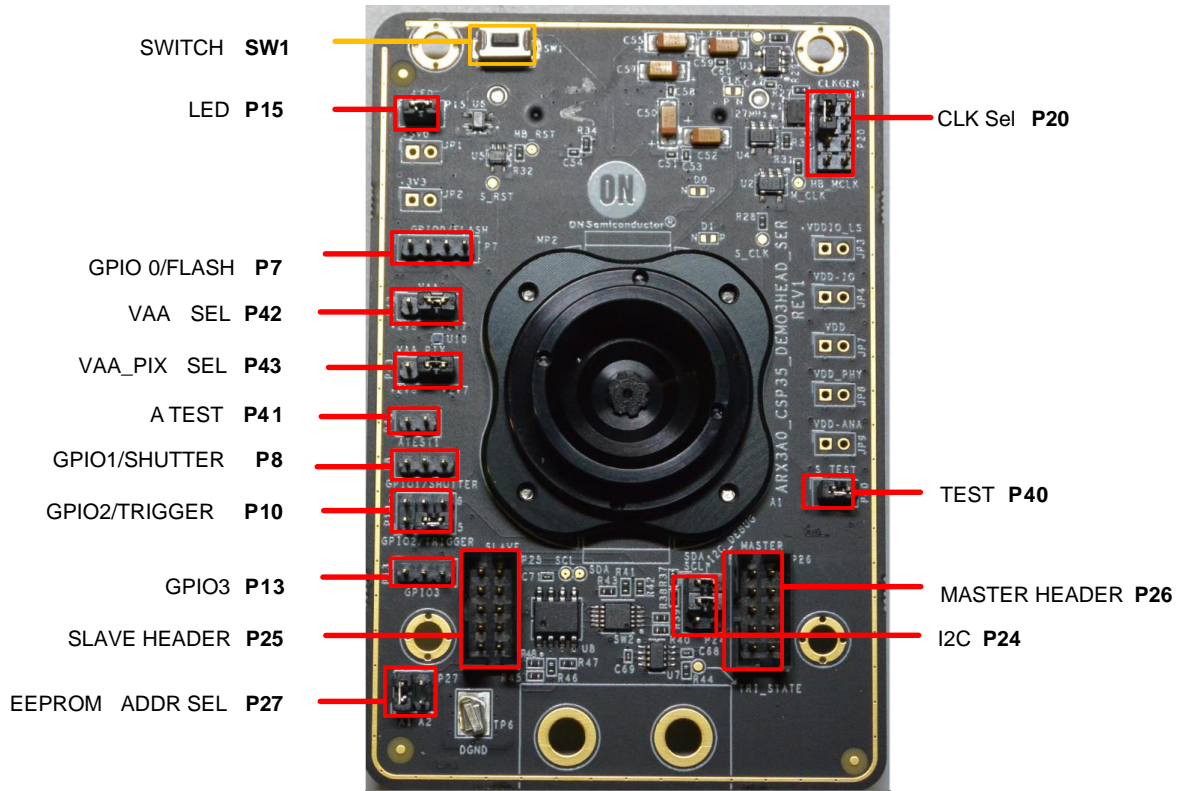

Figure 3. Top View of Evaluation Board – Default Jumpers

## Bottom View

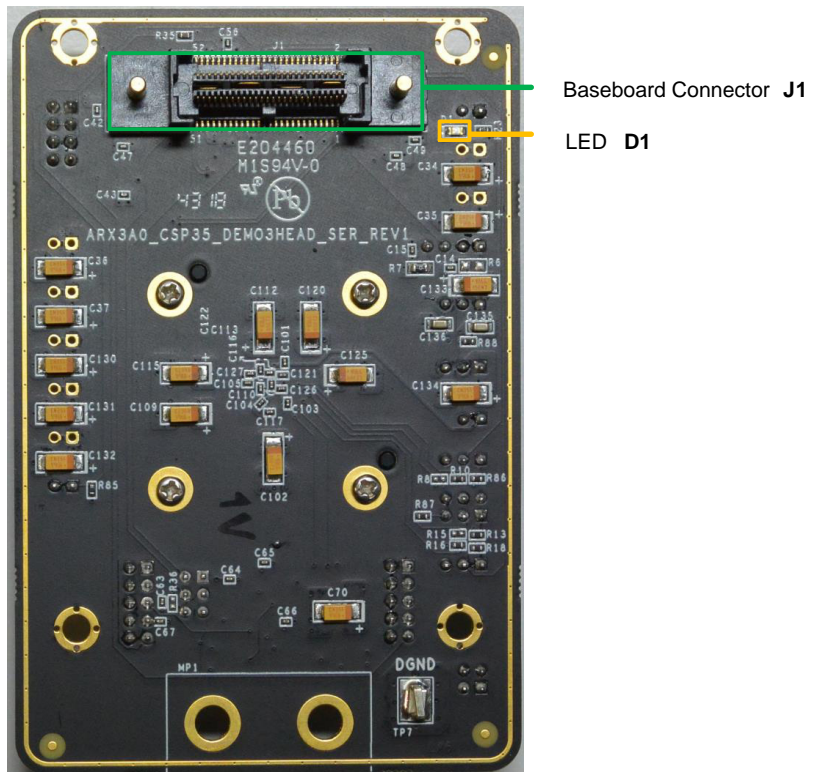

Figure 4. Bottom View of the Evaluation Board – Connector

# ARX3A0 – CSP35

## Jumper Locations

The jumpers on headboards start with Pin 1 on the leftmost side of the pin. Grouped jumpers increase in pin size with each jumper added.



**Figure 5. Pin Locations for a Single Jumper.**  
**Pin 1 is Located at the Leftmost Side and Increases as it Moves to the Right**

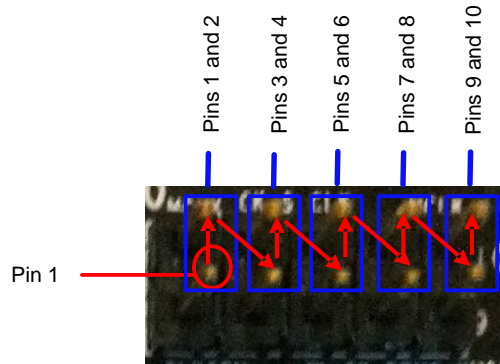

**Figure 6. Pin Locations and Assignments of Grouped Jumpers.**  
**Pin 1 is Located at the Bottom–Left Corner and Increases in a Zigzag Fashion Shown in the Picture (P10 and P27)**

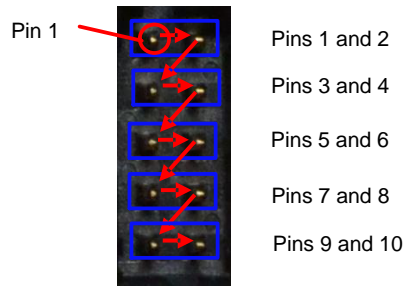

**Figure 7. Pin Locations and Assignments of Grouped Jumpers.**  
**Pin 1 is Located at the Top–Left Corner and Increases in a Zigzag Fashion Shown in the Picture (P20, P24, P25 and P26)**

## ARX3A0 – CSP35

### Jumper/Header Functions & Default Positions

**Table 1. JUMPERS AND HEADERS**

Jumper/Header No.	Jumper/Header Name	Pins	Description
P7	GPIO0/FLASH	Open (Default)	
		1	+5V0
		2	GND
		3	GPIO0/FLASH
		4	+3V3
P8	SHUTTER / GPIO1	Open (Default)	Normal Operation
		1–2	Pulled Up
		2–3	Pulled low
P10	GPIO2/TRIGGER	3–5 (Default)	GPIO2 Pull Down
		1–3	GPIO2 Pull Up
		2–4	Trigger from Demo3
		Pin 4	Function Generator Input
P13	GPIO3	Open (default)	Normal Operation / Multi-Camera Slave Mode
		1–2	GPIO3 Pulled up
		2–3	GPIO3 Pulled down / Master Mode
P15	LED	1–2 (Default)	Power LED ON
		Open	Power LED OFF
P20	CLK Selection	1–3 (Default)	Select on-board oscillator clock & enable master clock output
		2–4	Select Slave clock (for slave sensor in multi-camera mode)
		3–5	Select Demo3 clock
		6–8	Enable Master clock (to support slave sensor in multi-camera mode)
P24	I <sup>2</sup> C	1–2 & 3–4 (Default)	Demo3 SCL & SDA connected to sensor SCL & SDA respectively
P25, P26	Multi Camera (Slave/Master)		Refer schematics for the connection
P27	EEPROM Addr. Sel	1–2 Closed & 3–4 Open (Default)	EEPROM Address set to 0xA8
		1–2 open & 3–4 Open	EEPROM Address set to 0xAC
		1–2 open & 3–4 closed	EEPROM Address set to 0xA4
		1–2 Closed & 3–4 closed	EEPROM Address set to 0xA0
P40	TEST	1–2 (Default)	Normal Mode Operation
		Open	Test Mode
P41	ATEST1	Open (Default)	Normal operation
		Pin 1 & 2	Analog manufacturing test access
P42	VAA Sel	2–3 (Default)	VAA is at 2.7 V from the on board LDO
		1–2	VAA is at 2.8 V from Demo3 Baseboard
P43	VAA-PIX Sel	2–3 (Default)	VAA-PIX is at 2.7 V from the on board LDO
		1–2	VAA-PIX is at 2.8 V from Demo3 Baseboard
SW1	RESET	N/A	When pushed, 240 ms reset signal will be sent to ARX3A0

## ARX3A0 – CSP35

### Interfacing to ON Semiconductor Demo3 Baseboard

The ON Semiconductor Demo3 baseboard has a similar 52-pin connector P5 which mates with J1 of the headboard. The four mounting holes secure the baseboard and the headboard with spacers and screws.

### Shorted Jumpers for Power Measurement

Different supplies to the evaluation board are provided by trace shorted jumper, for any voltage and power measurements. To conduct current measurement on a given power rail, cut the trace between the two pins of their respective JP, and insert an ammeter prior to powering up the system. The figure below shows where the trace to cut is located.

**Table 2. SHORTED JUMPERS FOR POWER MEASUREMENT**

Jumper	Voltage (V)
JP1 (From Demo3)	5.0
JP2 (Peripheral 3.3V)	3.3
JP3 (VDDIO_LS)	1.8
JP4 (VDDIO)	1.8
JP7 (VDD)	1.2
JP8 (VDD-PHY)	1.2
JP9 (VDD-ANA)	1.2
P42 (VAA)	2.7
P43 (VAA-PIX)	2.7

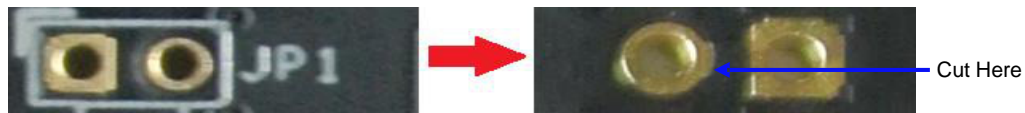

**Figure 8. Top and Bottom View of Shorted Jumper.  
The Bottom View Shows the Trace Location to Cut for Current Measurement.**