

# SPECIFICATIONS

PARAMETERS	VALUES	UNITS
RATED INPUT POWER	0.1	W
MAX INPUT POWER	0.2	W
IMPEDANCE	8 ± 15%	OHM
OUTPUT SPL @ .1W/1M (AT 0.8, 1.0, 1.2, 1.5 kHz)	89 ± 3	dBA
DISTORTION (MAX.)	5%	-
RESONANT FREQUENCY	800 ± 20%	Hz
FREQUENCY RANGE	Fo ~ 5,000	Hz
HOUSING MATERIAL	METAL	-
CONE MATERIAL	PAPER	-
MAGNET MATERIAL	NdFeB	-
OPERATING TEMPERATURE	-20 ~ +60	°C
WEIGHT	13	grams

THIS DOCUMENT CONTAINS DATA PROPRIETARY TO PROJECTS UNLIMITED, INC. ANY USE OR REPRODUCTION, IN ANY FORM, WITHOUT PRIOR WRITTEN PERMISSION OF PROJECTS UNLIMITED, INC. IS PROHIBITED.  
©2003, Projects Unlimited Inc.

# REVISION HISTORY

LTR	DESCRIPTION	DATE	APPROVED
-	RELEASED FROM ENGINEERING	6/6/2006	
A	REVISED TO INVENTOR 3-D DRAWINGS TEMPLATE	12/8/2008	B.R.
B	REVISED ELECTRICAL PARAMETERS	3/17/2017	M.L.

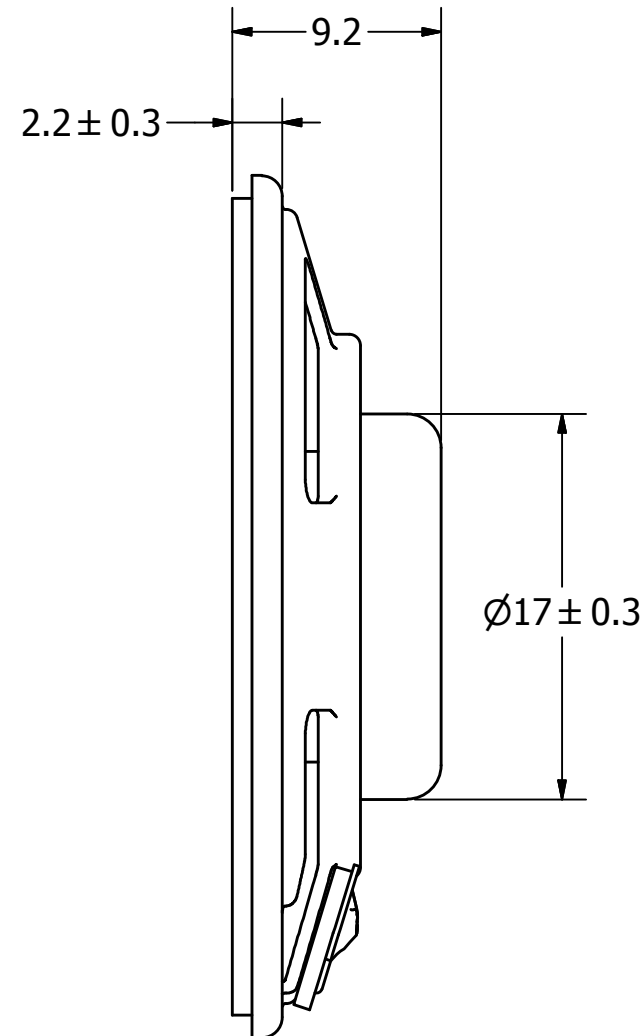
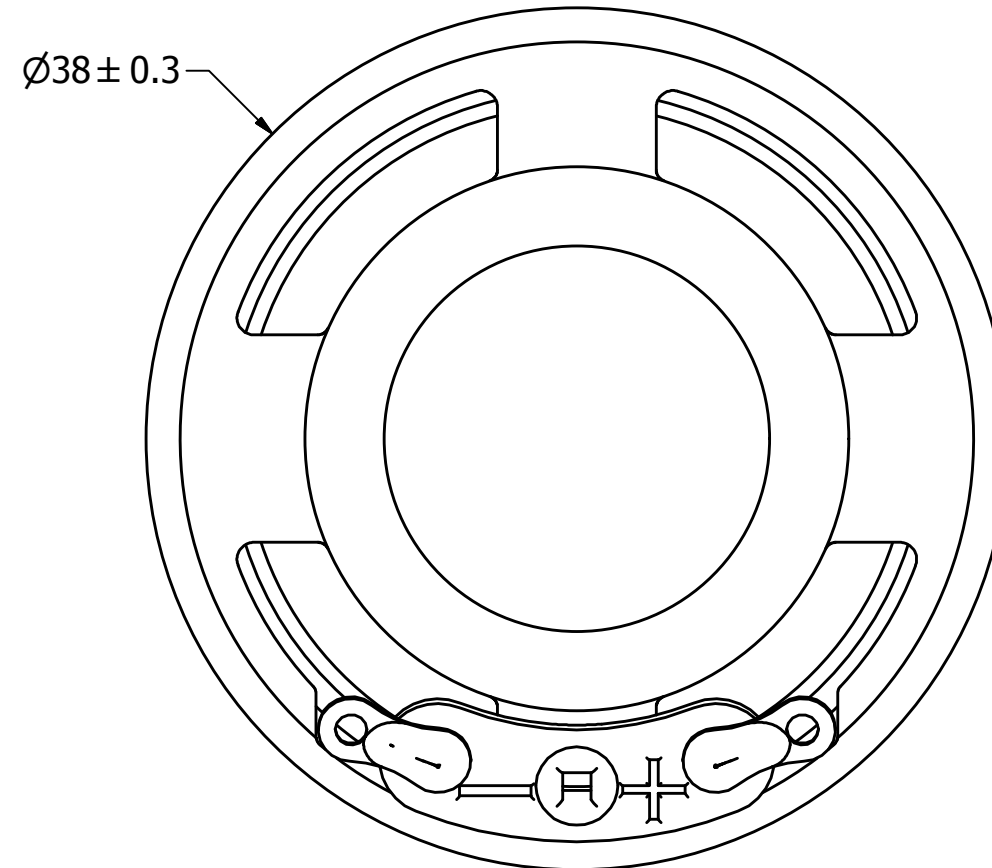

## NOTES:

1. ALL DIMENSIONS ARE IN MILLIMETERS.
2. SPECIFICATIONS SUBJECT TO CHANGE OR WITHDRAWL WITHOUT NOTICE.
3. THIS PART IS RoHS 2011/65/EU COMPLIANT.

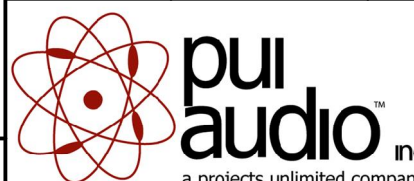
UNLESS OTHERWISE SPECIFIED: DIMENSIONS ARE IN MILLIMETERS, TOLERANCES ARE ±0.5 AND ANGLES ARE ±3°.	SIZE <b>A3</b>	Designed by	Date	Checked by	Date	Approved by	Date	Drawn Date
		J.D.	6/6/2006	E.P.	6/6/2006	B.R.	6/6/2006	12/8/2008
AS03808PR-R.idw				<b>AS03808PR-R</b>				
		<b>Speaker</b>			Edition	Sheet		
					-	1 / 1		