



austriamicrosystems AG

is now

ams AG

The technical content of this austriamicrosystems application note is still valid.

Contact information:

Headquarters:

ams AG
Tobelbaderstrasse 30
8141 Unterpremstaetten, Austria
Tel: +43 (0) 3136 500 0
e-Mail: ams_sales@ams.com

Please visit our website at www.ams.com

AS1110

Evaluation Board Application Note

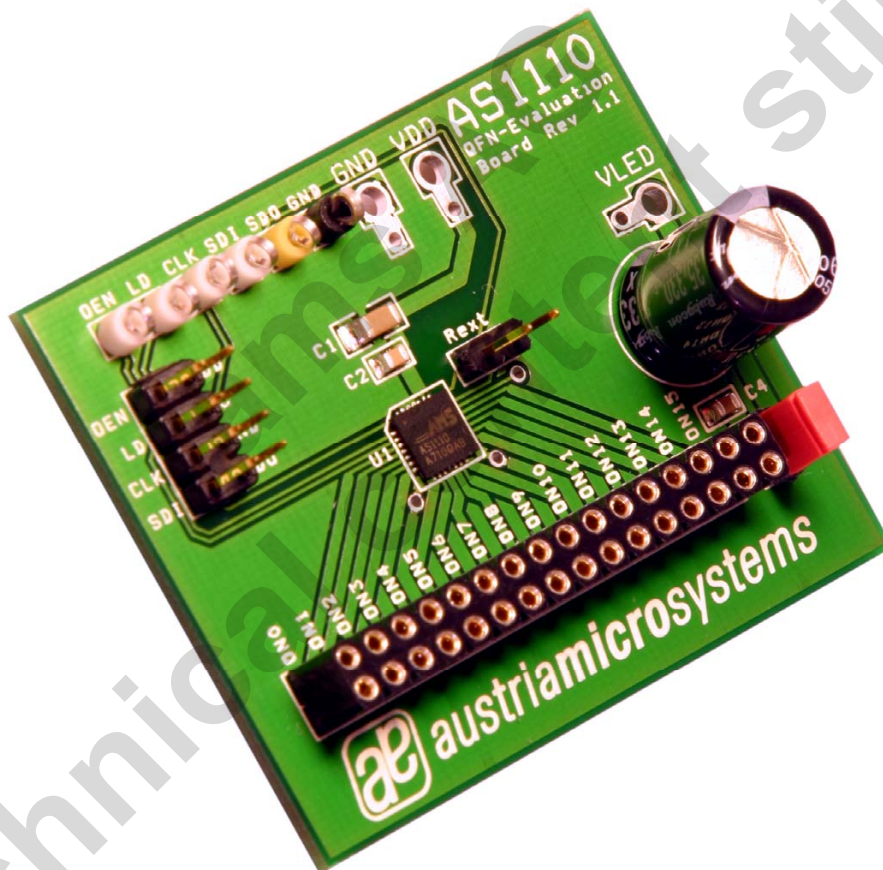

General Description

Board Description

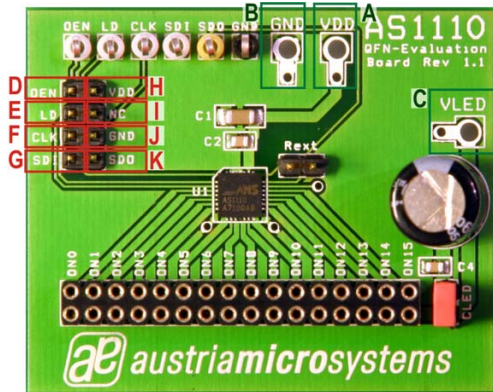

Figure 1: Board Description

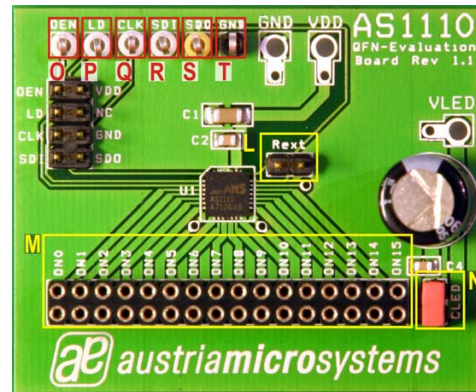

Figure 2: Board Description

Connector Description

Label	Name	Description	Info
A	VDD	Power Supply Connectors for VDD	+3.0V to +5.5V
B	GND	and Ground.	
C	VLED	Supply Voltage for the LED's	The output current drivers of the AS1110 can handle up to +15V.

Connector Description

Label	Name	Description	Info
D	OEN	Output Enable	0: Output drivers enabled; 1: Output drivers disabled
E	LD	Serial Data Load	Data transferred at the rising edge.
F	CLK	Serial Data Clock	
G	SDI	Serial Data Input	
H	VDD	Positive Supply Voltage	
I	NC	Not connected	
J	GND	Ground	
K	SDO	Serial Data Output	

Components Connectors Description

Label	Name	Description	Info
L	Rext	External Resistor	Place resistor here to set the load current.
M	ON0-7	Output Current Drivers	Connector for LED's. Upper side interfaces with the output drivers of the AS1110 while the lower side connects to VLED.
N	CLED	Decoupling Capacity of LEDs	Jumper to (dis)connect the onboard capacity.

Measurement Points Description

Label	Name	Description	Info
O	OEN	Output Enable	0: Output drivers enabled; 1: Output drivers disabled
P	LD	Serial Data Load	Data transferred at the rising edge.
Q	CLK	Serial Data Clock	
R	SDI	Serial Data Input	
S	SDO	Serial Data Output	
T	GND	Ground	

Operational sequence

1. If not present get the [datasheet](#) for the AS1110 from www.austriamicrosystems.com. Use the IC on the evaluation board only with the recommended settings and values as described in the [datasheet](#).
2. Place an external resistor in Rext "L" to set the LED current. If another capacitance then 330µF 35V is needed it is possible to disconnect the onboard capacity through the Jumper CLED "N". Connect the LEDs with the output current drivers "M".
3. Connect a +3.0V to +5.5V power supply (VDD "A" and GND "B" or VDD "H" and GND "J").
4. Connect a voltage supply to VLED "C". The output drivers sustain a maximum voltage of +15V at the pin.
5. Connect the Serial Data Interface. For the data format of the serial interface please see the [datasheet](#) for the AS1110.

Have fun using the evaluation board. If there are questions do not hesitate to contact us. See contact information at the end of the application note.

Layout of demoboard

Board schematics and layout

Figure 3: Schematics

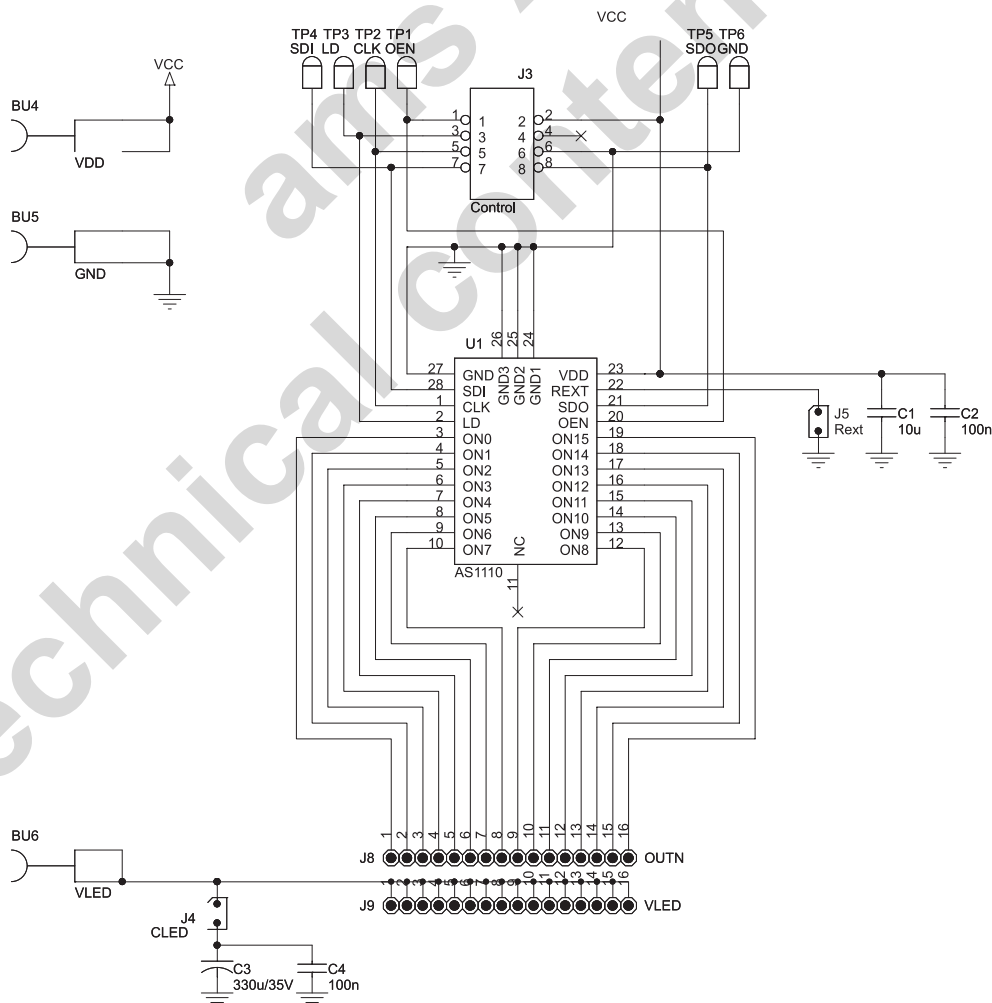

Figure 4: Top view

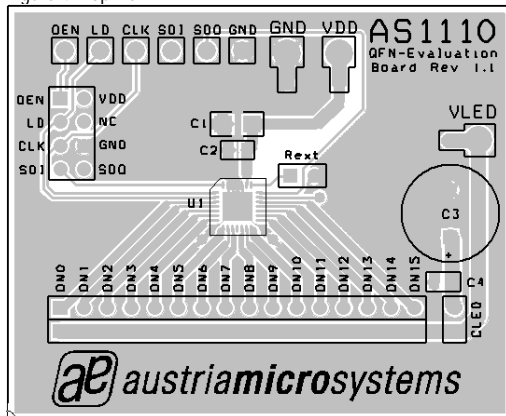
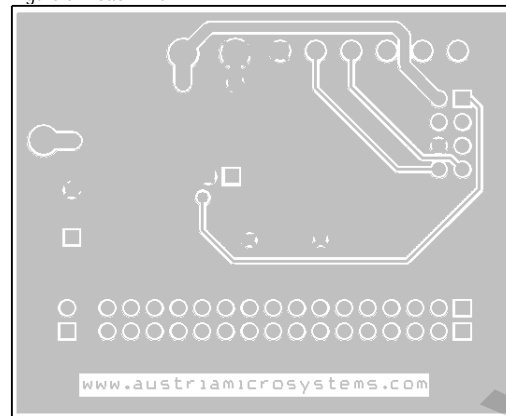

Figure 5: Bottom view



Recommended parts

Label	Info	Type	Manufacturer
C1	10 μ F, \pm 10%, 16V, X7R	GRM31CR71C106KAC7	Murata
C2, C4	0.1 μ F, \pm 10%, 50V, X7R	GRM21BR71H104KA01	Murata
C3	330u, 35V, Electrolytic Condensator		