



**Eval Kit Manual**

# **AS1111A**

**Standard Board**

**AS1111A-WL\_EK\_ST**

## Content Guide

1	Introduction .....	3
2	Kit Content .....	3
3	Getting Started .....	3
4	Hardware Description.....	4
5	Schematics, Layers and BOM .....	6
5.1	Schematic of AS1111A Evaluation Board.....	6
5.2	Layers .....	7
5.3	Bill of Materials.....	8
6	Ordering & Contact Information .....	9
7	Copyrights & Disclaimer.....	10
8	Revision Information .....	10

## 1 Introduction

This document describes the AS1111A Evaluation Kit.

The AS1111A is a LED driver designed to match current source bias for any color LED, including white and blue. The devices can drive up to 2 high-current LEDs, and the LED current is programmable using an external resistor (RSET).

The AS1111A LED currents are  $460 \times I_{SET}$  (per LED, type) at an LED cathode voltage (VSAT) of 150mV and  $650 \times I_{SET}$  (type) at a VSAT of 1V, where ISET is the current through RSET connected to pin CTRL.

The AS1111A incorporate a chip-enable feature via pin EN. When the devices is disabled, the supply current drops down to less than 1µA. The AS1111A are available in a 6-pin WL-CSP package with 0.4mm pitch.

## 2 Kit Content

Figure 1: Kit Content

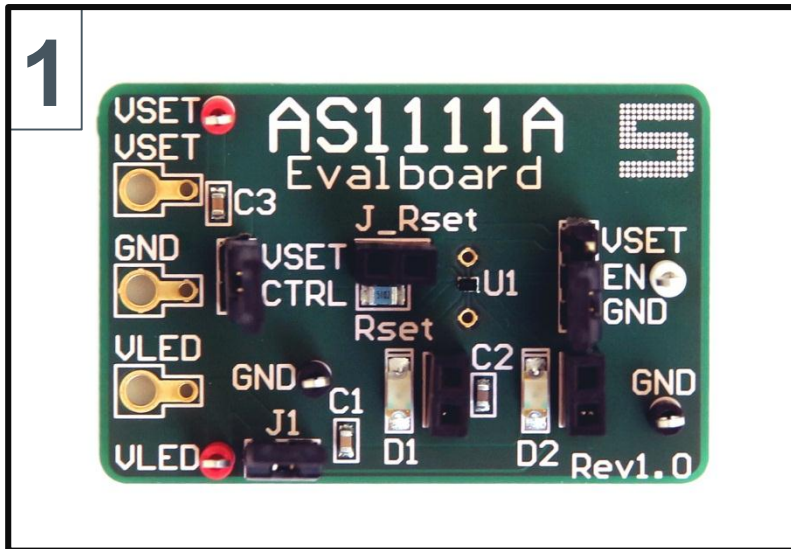

Label	Item	Comment
1	Evaluation Board	AS1111A (6-pin WL-CSP package with 0.4mm pitch)

## 3 Getting Started

Connect your supply to GND, VSET and VLED. Be shure that the jumpers are set like you can see in the Hardware Description below.

## 4 Hardware Description

Figure 2: Evaluation Board Overview

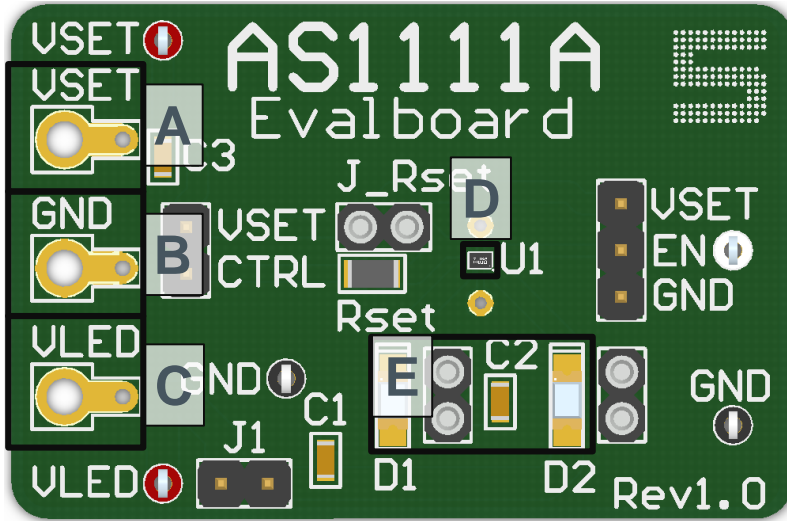

Label	Name	Designator	Description	Info
A	VSET	VSET	Voltage	Voltage to set the LED Current
B	GND	GND	Ground	
C	VLED	VLED	LED Supply	Supply Voltage for the LED's
D	AS1111A	U1	LED – driver	
E	LED's	D1, D2		

Figure 3: Jumper and device locations

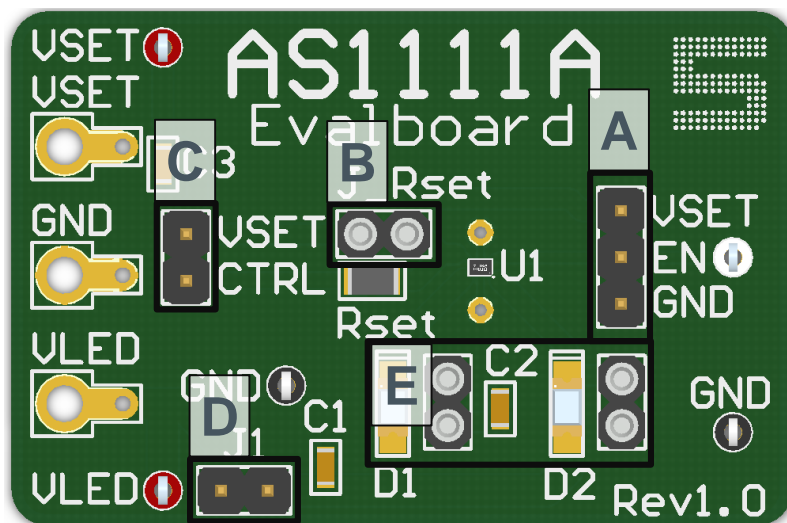



Label	Name	Designator	Description	Info
A	J_EN	J_EN	Enable or Disable the LED – driver	 GND - disabled  VSET - enabled
B	RSET	J_Rset		Connect different kind of RSET or you can make a parallel connection. Depending on Jumper J_CTRL.
C	J_CTRL	J_CTRL		Connect / Disconnect the soldered (51k) RSET resistor
D	J1	J1	Jumper	Connect / Disconnect LED's
E	LED's	J_D1, J_D2	Female Header	Connect different kind of LED's

Figure 4: Measurement Points



Label	Name	Designator	Description	Info
A	VSET	VSET	Voltage to set the LED current	Measurement Point
B	LED Voltage	VLED	Supply Voltage for the LED's	Measurement Point
C	GND	GND	Ground	Measurement Point
D	Enable	EN	$V_{EN} \geq 2.2V$ : VOUT is enabled $V_{EN} \leq 0.5V$ : VOUT is disabled	Measurement Point
E	GND	GND	Ground	Measurement Point

## 5 Schematics, Layers and BOM

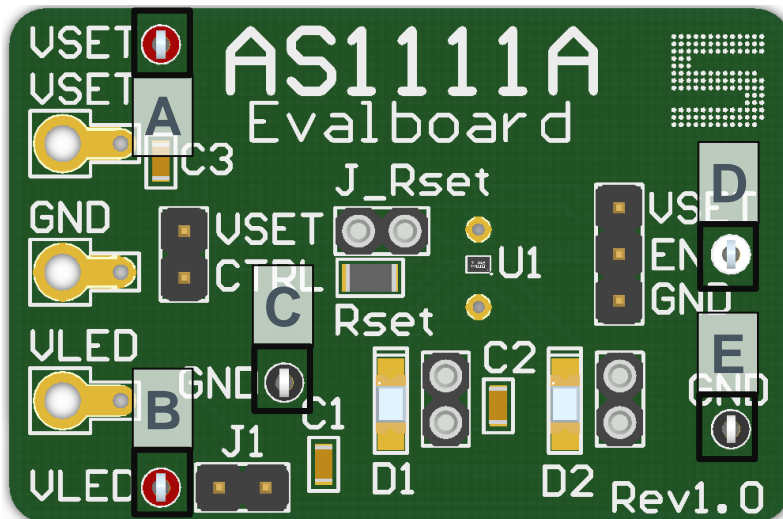
### 5.1 Schematic of AS1111A Evaluation Board

Figure 5: Schematic

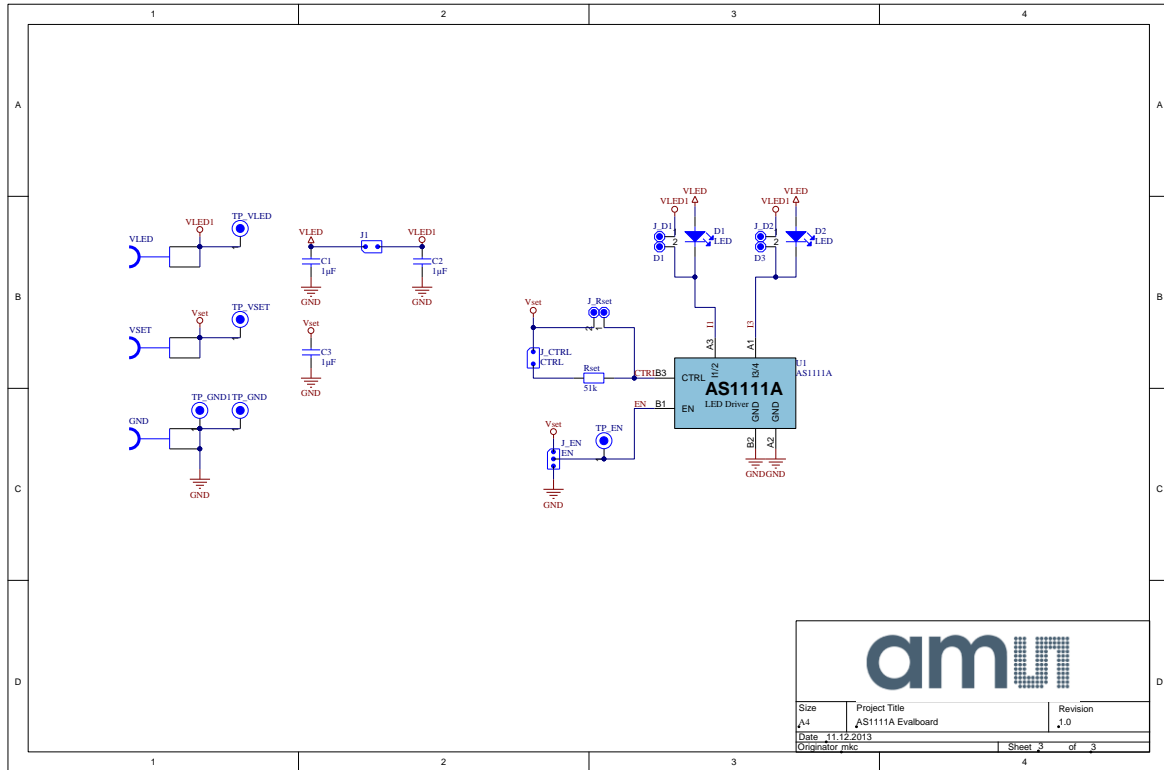

## 5.2 Layers

Figure 6: Top Layer

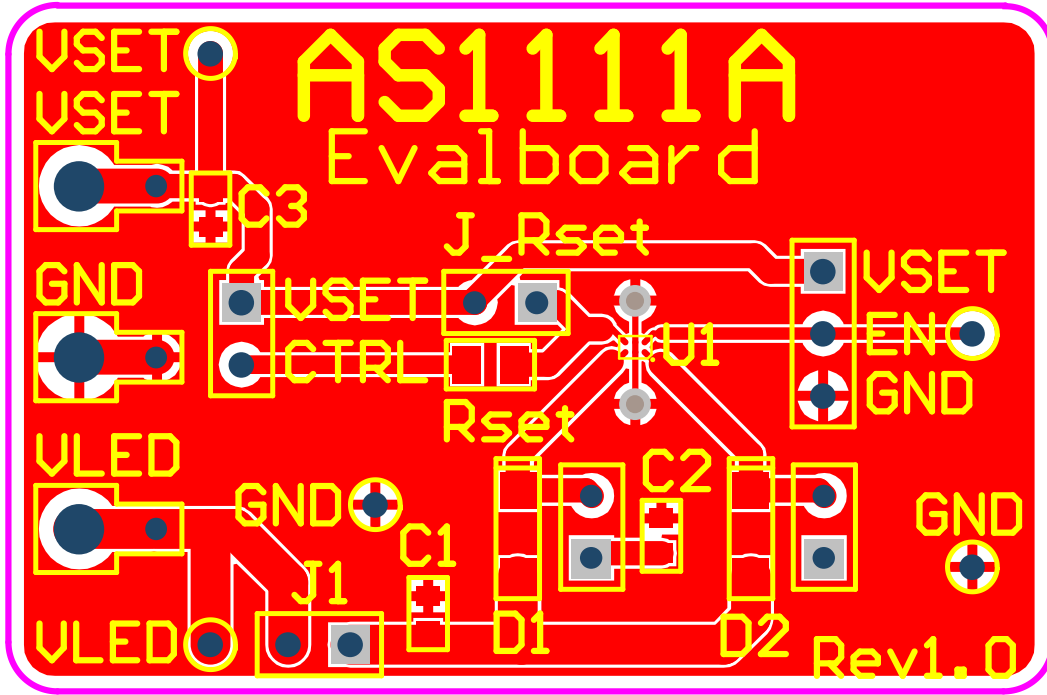
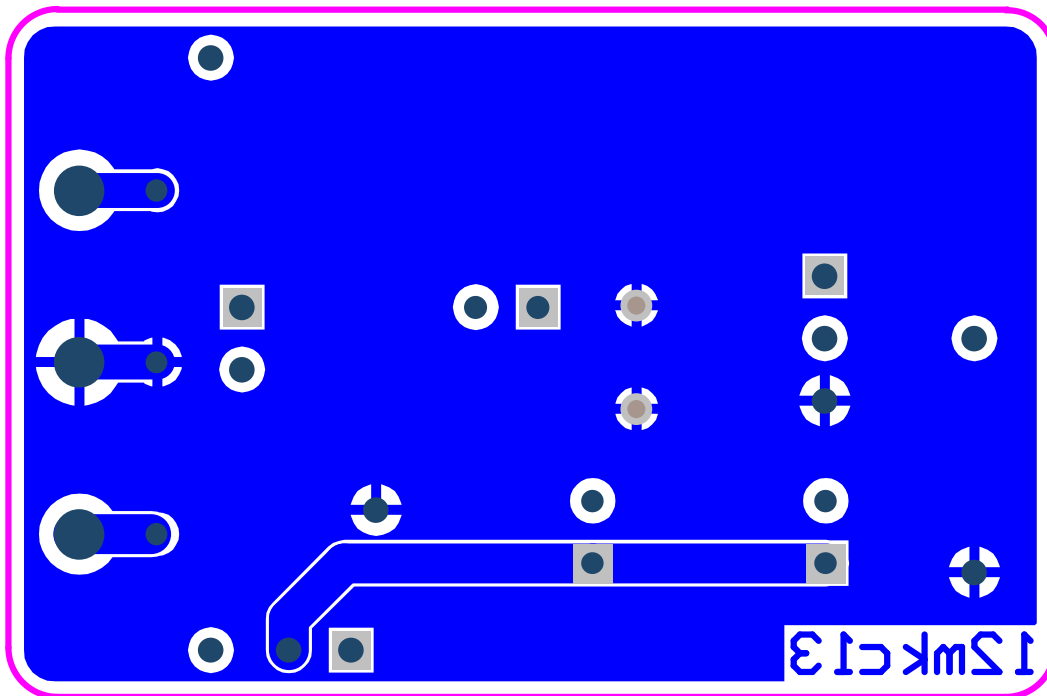

Figure 7: Bottom Layer



### 5.3 Bill of Materials

Figure 8: BOM

Bill of Materials			AS1111A Evalboard			
Company:			ams AG			
Originator:			mkc			
PCB Name:			AS1111A Evalboard			
PCB Version:			1.0			
Report Date:			11.12.2013			
#	Designator	Comment	Component_Description	Manufacturer	Manufacturer Part Number	Quantity
1	C1, C2, C3	1µF	CAP CER 1UF 16V 20% X5R 0603	Murata Electronics North America	GRM188R61C105MA12D	3
2	D1, D2	LED	LED 3.2X1.6MM 630NM RED CLR SMD	Kingbright	APT3216SURCK	2
3	J1, J_CTRL	2 PIN, CTRL	3M - 961102-6404-AR - CONNECTOR, HEADER, 2POS, 1ROW, 2.54MM	3M	961102-6404-AR	2
4	J_D1, J_D2, J_Rset	D1, D3	SAMTEC - SSA-102-S-G - BUCHSE, 2.54MM, LPT, 2KONT	SAMTEC	SSA-102-S-G	3
5	J_EN	EN	3M - 961103-6404-AR - BOARD TO BOARD, HEADER, 3POS, 1ROW	3M	961103-6404-AR	1
6	Rset	51k	MULTICOMP - MCD01W0805151K - WIDERSTAND, 51K, 0.1W, 1%, 0805	MULTICOMP	MCD01W0805151K	1
7	TP_EN	Testpoint	VERO - 20-313139 - PRÜFPUNKT, PCB, WEISS, PK100	VERO	20-313139	1
8	TP_GND, TP_GND1	Testpoint	VERO - 20-2137 - PRÜFPUNKT, PCB, SCHWARZ, PK100	VERO	20-2137	2
9	TP_VLED, TP_VSET	Testpoint	VERO - 20-313137 - PRÜFPUNKT, PCB, ROT, PK100	VERO	20-313137	2
10	U1	AS1111A			AS1111A-WL_BK_ST	1
<b>Approved</b>			<b>Notes</b>			<b>16</b>



## 6 Ordering & Contact Information

Ordering Code	Description
AS1111A-WL_EK_ST	AS1111A Eval Kit Standard Board

**Buy our products or get free samples online at:**

[www.ams.com/ICdirect](http://www.ams.com/ICdirect)

**Technical Support is available at:**

[www.ams.com/Technical-Support](http://www.ams.com/Technical-Support)

**Provide feedback about this document at:**

[www.ams.com/Document-Feedback](http://www.ams.com/Document-Feedback)

**For further information and requests, e-mail us at:**

[ams\\_sales@ams.com](mailto:ams_sales@ams.com)

**For sales offices, distributors and representatives, please visit:**

[www.ams.com/contact](http://www.ams.com/contact)

### Headquarters

ams AG

Tobelbaderstrasse 30

8141 Unterpemstaetten

Austria, Europe

Tel: +43 (0) 3136 500 0

Website: [www.ams.com](http://www.ams.com)