

**RevisionHistory**

512 Kb x16 Pseudo Static RAM

**48ball-FPBGA**

Revision	Details	Date
Rev 1.0	Preliminary datasheet	Aug. 2018

## GENERAL DESCRIPTION

The AS1C512K16P-70BIN is 8,388,608 bits of Pseudo SRAM which uses DRAM type memory cells, but this device has refresh-free operation and extreme low power consumption technology. Furthermore the interface is compatible to a low power Asynchronous type SRAM. The AS1C512K16P-70BIN is organized as 524,288 Words x 16 bit.

## FEATURES

- Organization :512K x16
- Address access speed 70ns
- Power Supply Voltage : 2.6 ~ 3.3V
- Separated I/O power(V<sub>CCQ</sub>) & Core power(V<sub>CC</sub>)
- Three state outputs
- Byte read/write control by UB# / LB#
- Auto-TCSR for power saving
- Package type : 48-FPBGA 6.0x7.0
- Operating Temperature
  - . Industrial : -40 °C ~ 85 °C

## PRODUCT FAMILY

Part Number	Operating Temp.	Power Supply	Speed (t <sub>RC</sub> )	Power Dissipation		
				Standby (I <sub>SB</sub> , Max.)	Operating I <sub>CC</sub> ( Max.)	
					I <sub>CC1</sub> ( f = 1MHz)	I <sub>CC2</sub> ( f = f <sub>max</sub> )
AS1C512K16P-70BIN	-40 °C to 85 °C	2.6V to 3.3V	70ns	120uA	5mA	25mA

## FUNCTION BLOCK DIAGRAM

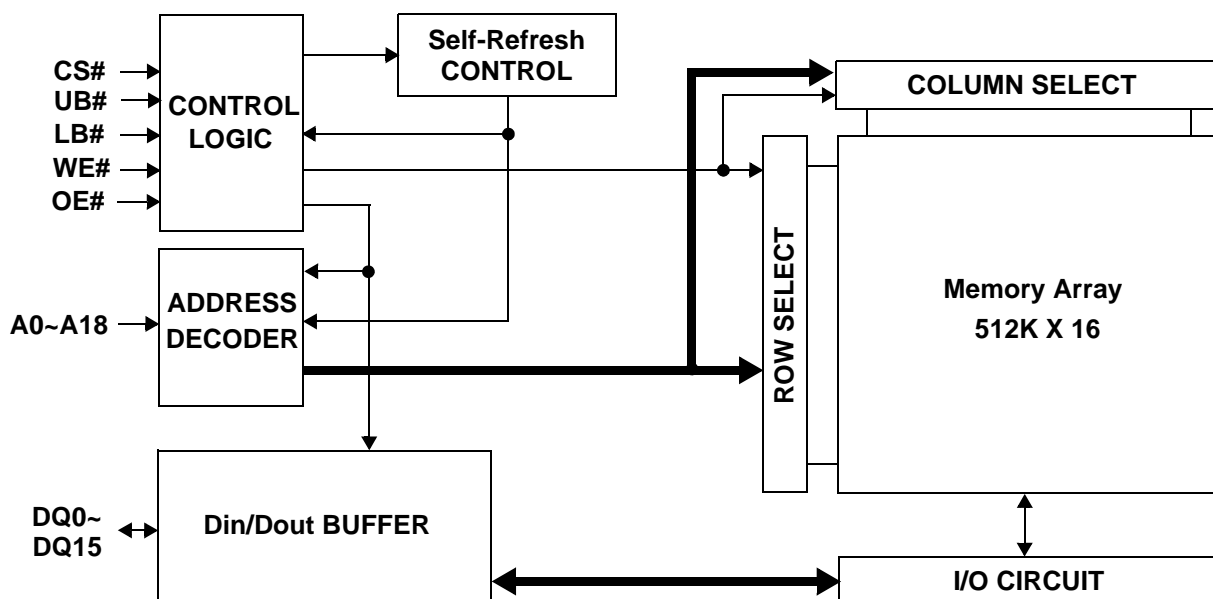

## PIN DESCRIPTION ( 48-FPBGA-6.00x7.00 )

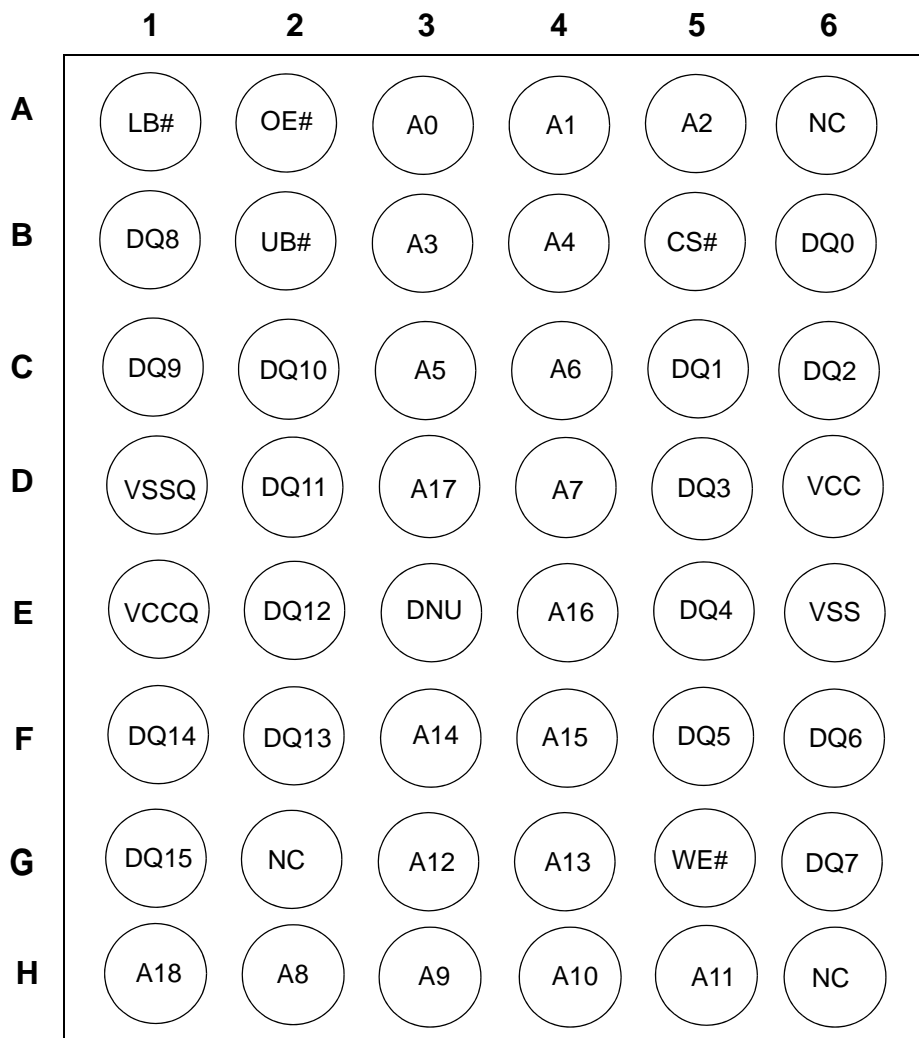

**TOP VIEW (Ball Down)**

Name	Function	Name	Function
CS#	Chip select input	LB#	Lower byte (DQ <sub>0-7</sub> )
OE#	Output enable input	UB#	Upper byte (DQ <sub>8-15</sub> )
WE#	Write enable input	VCC	Power supply
DQ <sub>0-15</sub>	Data in-out	VCCQ	I/O power supply
A <sub>0-18</sub>	Address inputs	VSS(Q)	Ground
DNU	Do not use	NC	No connection

## ABSOLUTE MAXIMUM RATINGS <sup>1)</sup>

Parameter		Symbol	Ratings	Unit
Voltage on Any Pin Relative to Vss		V <sub>IN</sub> , V <sub>OUT</sub>	-0.2 to V <sub>CCQ</sub> +0.3	V
Voltage on Vcc supply relative to Vss		V <sub>CC</sub> , V <sub>CCQ</sub>	-0.2 <sup>2)</sup> to V <sub>CCQ</sub> +0.3V	V
Power Dissipation		P <sub>D</sub>	1.0	W
Storage Temperature		T <sub>STG</sub>	-65 to 150	°C
Operating Temperature	Industrial	T <sub>A</sub>	-40 to 85	°C

- Stresses greater than those listed above "Absolute Maximum Ratings" may cause permanent damage to the device. Functional operation should be restricted to recommended operating condition. Exposure to absolute maximum rating conditions for extended periods may affect reliability.
- Undershoot at power-off : -1.0V in case of pulse width  $\leq$  20ns

## FUNCTIONAL DESCRIPTION

CS#	OE#	WE#	LB#	UB#	DQ <sub>0~7</sub>	DQ <sub>8~15</sub>	Mode	Power
H	X	X	X	X	High-Z	High-Z	Deselected	Stand by
L	H	H	L	X	High-Z	High-Z	Output Disabled	Active
L	H	H	X	L	High-Z	High-Z	Output Disabled	Active
L	L	H	L	H	Data Out	High-Z	Lower Byte Read	Active
L	L	H	H	L	High-Z	Data Out	Upper Byte Read	Active
L	L	H	L	L	Data Out	Data Out	Word Read	Active
L	X	L	L	H	Data In	High-Z	Lower Byte Write	Active
L	X	L	H	L	High-Z	Data In	Upper Byte Write	Active
L	X	L	L	L	Data In	Data In	Word Write	Active

Note:

- X means don't care. (Must be low or high state)

## RECOMMENDED DC OPERATING CONDITIONS

Parameter	Symbol	Min	Typ	Max	Unit
Supply voltage	$V_{CC}$	2.6	3.0	3.3	V
	$V_{CCQ}$	2.6	3.0	3.3	V
Ground	$V_{SS}, V_{SSQ}$	0	0	0	V
Input high voltage	$V_{IH}$	$0.8 * V_{CCQ}$	-	$V_{CCQ} + 0.2^{1)}$	V
Input low voltage	$V_{IL}$	$-0.2^{2)}$	-	$0.2 * V_{CCQ}$	V

1. Overshoot:  $V_{CC} + 1.0$  V in case of pulse width  $\leq 20$ ns
2. Undershoot:  $-1.0$  V in case of pulse width  $\leq 20$ ns
3. Overshoot and undershoot are sampled, not 100% tested.

## CAPACITANCE<sup>1)</sup> ( $f=1$ MHz, $T_A=25^\circ$ C)

Item	Symbol	Test Condition	Min	Max	Unit
Input capacitance	$C_{IN}$	$V_{IN}=0$ V	-	8	pF
Input/Output capacitance	$C_{IO}$	$V_{IO}=0$ V	-	8	pF

1. Capacitance is sampled, not 100% tested

## DC AND OPERATING CHARACTERISTICS

Parameter	Symbol	Test Conditions	Min	Typ	Max	Unit
Input leakage current	$I_{LI}$	$V_{IN}=V_{SS}$ to $V_{CCQ}$ , $V_{CC}=V_{CCmax}$	-1	-	1	$\mu$ A
Output leakage current	$I_{LO}$	$CS\#=V_{IH}$ , $OE\#=V_{IH}$ or $WE\#=V_{IL}$ , $V_{IO}=V_{SS}$ to $V_{CCQ}$ , $V_{CC}=V_{CCmax}$	-1	-	1	$\mu$ A
Average operating current	$I_{CC1}$	Cycle time = 1 $\mu$ s, $I_{IO}=0$ mA, 100% duty, $CS\#\leq 0.2$ V, $V_{IN}\leq 0.2$ V or $V_{IN}\geq V_{CCQ}-0.2$ V	-	-	5	mA
	$I_{CC2}$	Cycle time = Min, $I_{IO}=0$ mA, 100% duty, $CS\#=V_{IL}$ , $V_{IN}=V_{IL}$ or $V_{IH}$	-	-	25	mA
Output low voltage	$V_{OL}$	$I_{OL} = 0.5$ mA, $V_{CC}=V_{CCmin}$	-	-	$0.2 * V_{CCQ}$	V
Output high voltage	$V_{OH}$	$I_{OH} = -0.5$ mA, $V_{CC}=V_{CCmin}$	$0.8 * V_{CCQ}$	-	-	V
Standby current (CMOS)	$I_{SB}$	$CS\#\geq V_{CCQ}-0.2$ V, Other inputs = 0 ~ $V_{CCQ}$ (Typ. condition : $V_{CC}=3.0$ V @ $25^\circ$ C) (Max. condition : $V_{CC}=3.3$ V @ $85^\circ$ C)	-	-	120	$\mu$ A

1. Maximum  $I_{CC}$  specifications are tested with  $V_{CC} = V_{CCmax}$ .

## AC OPERATING CONDITIONS

Test Conditions (Test Load and Test Input/Output Reference)

Input Pulse Level : 0.2V to  $V_{CCQ}-0.2V$

Input Rise and Fall Time : 5ns

Input and Output reference Voltage :  $V_{CCQ}/2$

Output Load (See right) :  $CL^{(1)} = 30pF$

1. Including scope and Jig capacitance

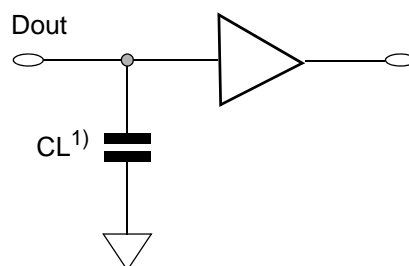

## AC CHARACTERISTICS

Parameter List		Symbol	Speed		Unit
			Min	Max	
Read	Read Cycle Time	$t_{RC}$	70	10k	ns
	Address access time	$t_{AA}$	-	70	ns
	Chip enable to data output	$t_{CO}$	-	70	ns
	Output enable to valid output	$t_{OE}$	-	25	ns
	UB#, LB# enable to data output	$t_{BA}$	-	25	ns
	Chip enable to low-Z output	$t_{LZ}$	10	-	ns
	UB#, LB# enable to low-Z output	$t_{BLZ}$	0	-	ns
	Output enable to low-Z output	$t_{OLZ}$	0	-	ns
	Chip disable to high-Z output	$t_{HZ}$	0	20	ns
	UB#, LB# disable to high-Z output	$t_{BHZ}$	0	20	ns
	Output disable to high-Z output	$t_{OHZ}$	0	20	ns
	Output hold from Address change	$t_{OH}$	5	-	ns
Write	Write Cycle Time	$t_{WC}$	70	10k	ns
	Chip enable to end of write	$t_{CW}$	60	-	ns
	Address setup time	$t_{AS}$	0	-	ns
	Address valid to end of write	$t_{AW}$	60	-	ns
	UB#, LB# valid to end of write	$t_{BW}$	60	-	ns
	Write pulse width	$t_{WP}$	50	-	ns
	Write recovery time	$t_{WR}$	0	-	ns
	Write to output high-Z	$t_{WHZ}$	0	20	ns
	Data to write time overlap	$t_{DW}$	20	-	ns
	Data hold from write time	$t_{DH}$	0	-	ns
	End write to output low-Z	$t_{OW}$	5	-	ns

## TIMING DIAGRAMS

**READ CYCLE (1)** (Address controlled, CS#=OE#=V<sub>IL</sub>, WE#=V<sub>IH</sub>, UB# or/and LB#=V<sub>IL</sub>)

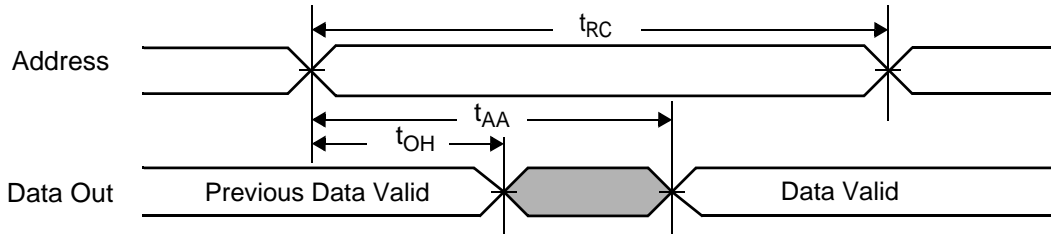

**READ CYCLE (2)** (WE#=V<sub>IH</sub>)

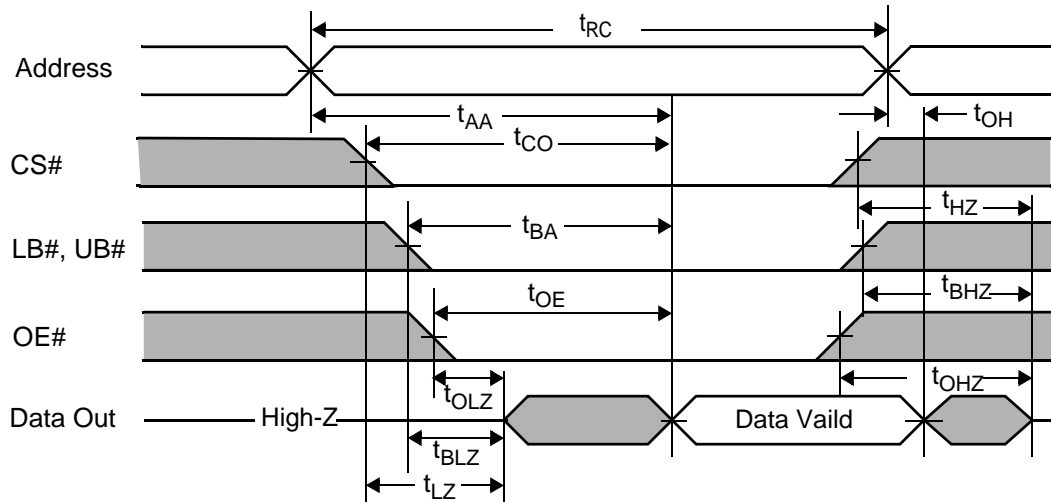

**NOTES (READ CYCLE)**

1.  $t_{HZ}$ ,  $t_{BHZ}$  and  $t_{OHZ}$  are defined as the time at which the outputs achieve the open circuit conditions and are not referenced to output voltage levels.
2. Do not Access device with cycle timing shorter than  $t_{RC}$  for continuous periods > 10us.

## WRITE CYCLE (1) (WE# controlled)

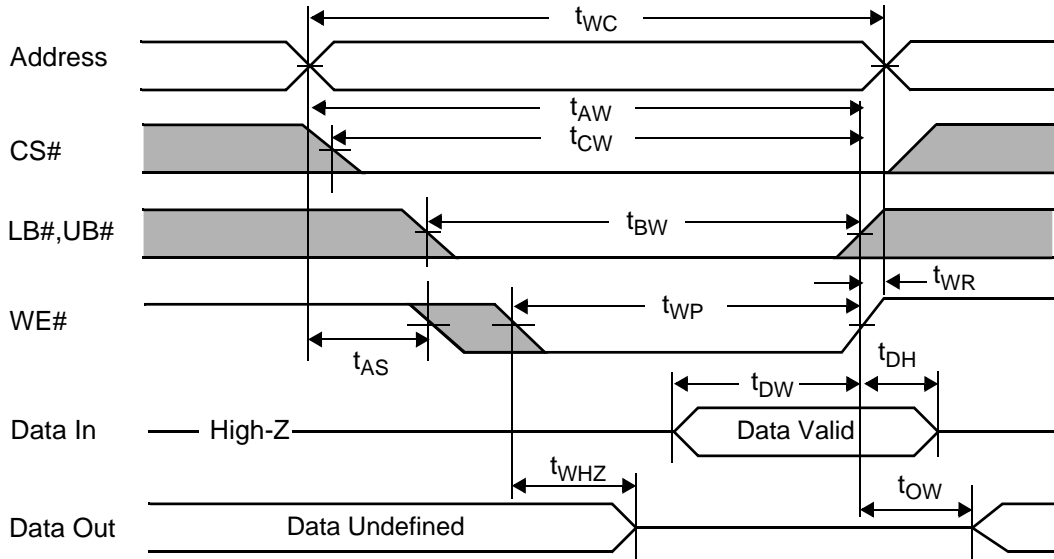

## WRITE CYCLE (2) (CS# controlled)

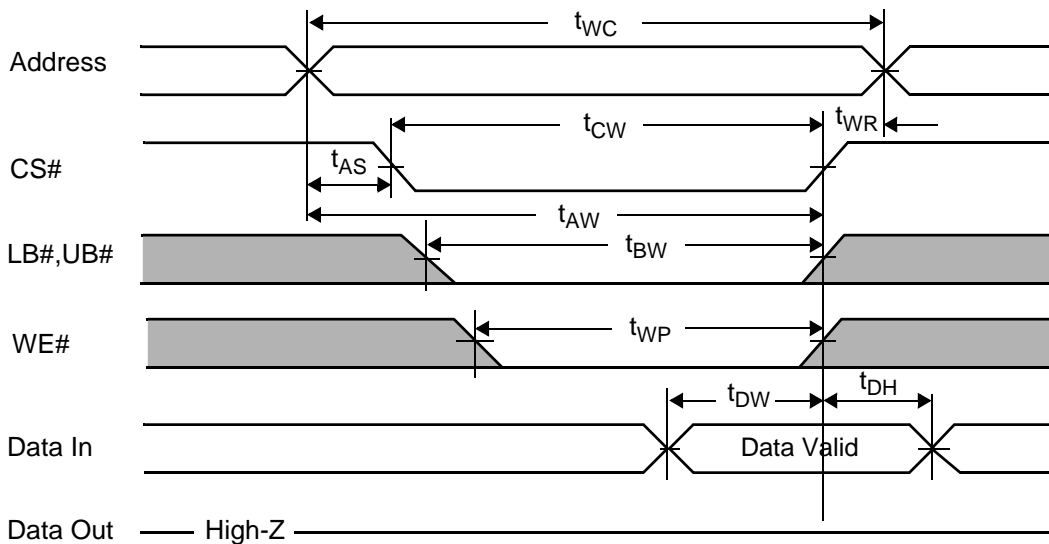

## WRITE CYCLE (3) (UB#/LB# controlled)

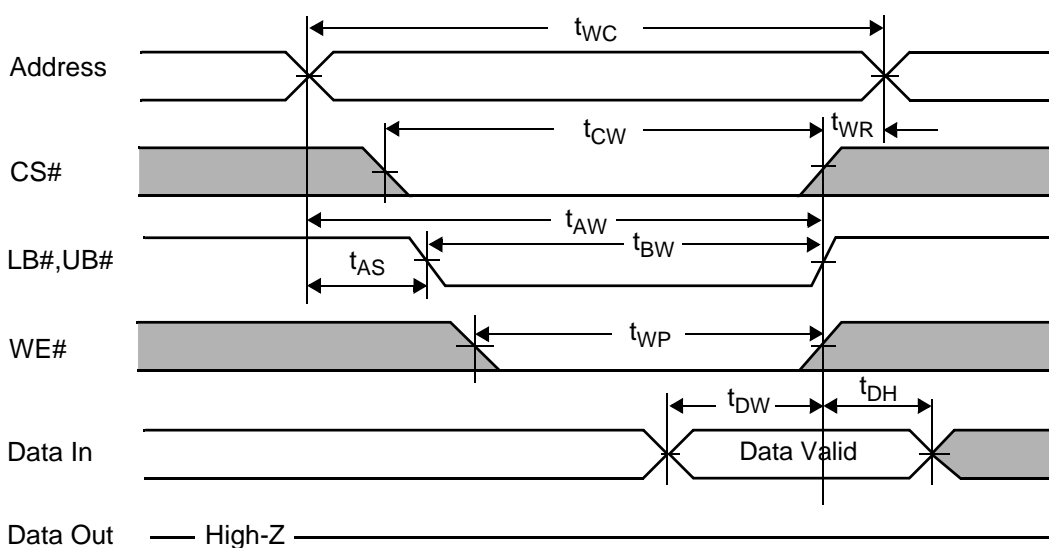



**NOTES (WRITE CYCLE)**

1. A write occurs during the overlap( $t_{WP}$ ) of low CS#, low WE# and low UB# or LB#. A write begins at the last transition among low CS# and low WE# with asserting UB# or LB# low for single byte operation or simultaneously asserting UB# and LB# low for word operation. A write ends at the earliest transition among high CS# and high WE#. The  $t_{WP}$  is measured from the beginning of write to the end of write.
2.  $t_{CW}$  is measured from CS# going low to end of write.
3.  $t_{AS}$  is measured from the address valid to the beginning of write.
4.  $t_{WR}$  is measured from the end of write to the address change.  $t_{WR}$  applied in case a write ends as CS# or WE# going high.
5. Do not access device with cycle timing shorter than  $t_{WC}$  for continuous periods > 10us.

**TIMING WAVEFORM OF POWER UP**

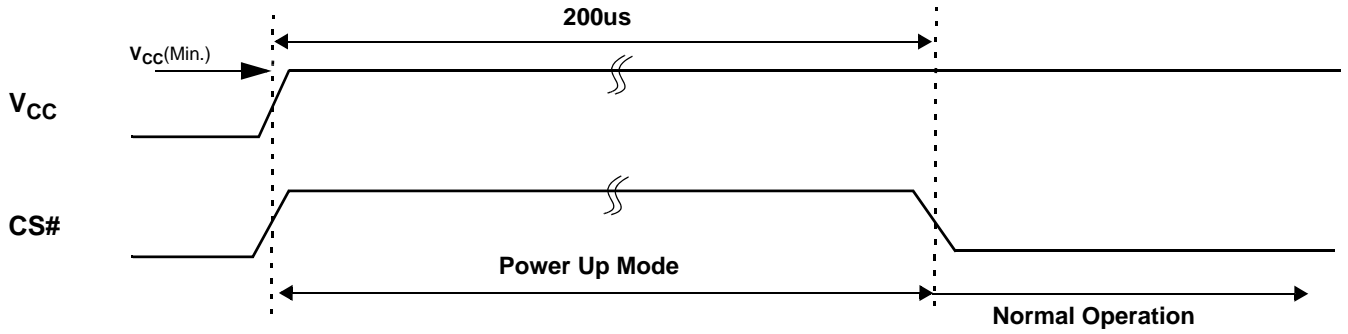

**NOTE ( POWER UP )**

1. After  $V_{CC}$  reaches  $V_{CC(Min.)}$  , wait  $200\mu s$  with  $CS\#$  high. Then you get into the normal operation.

Unit: millimeters

## PACKAGE DIMENSION

48 Ball Fine Pitch BGA (0.75mm ball pitch)

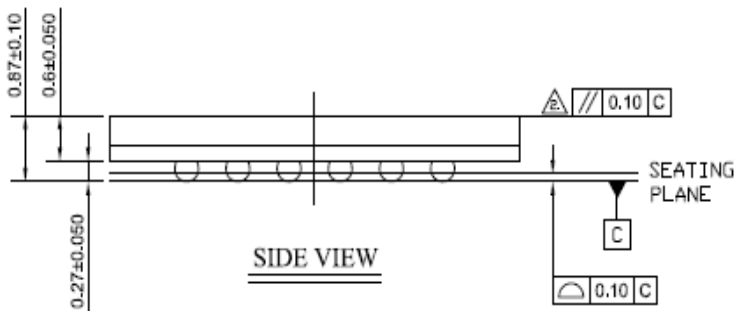
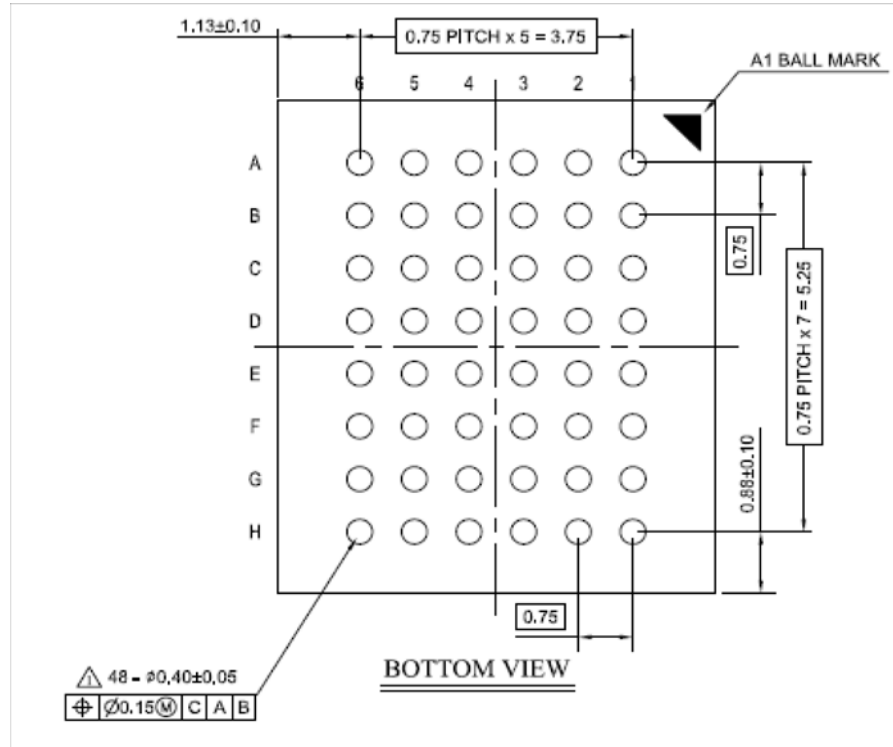
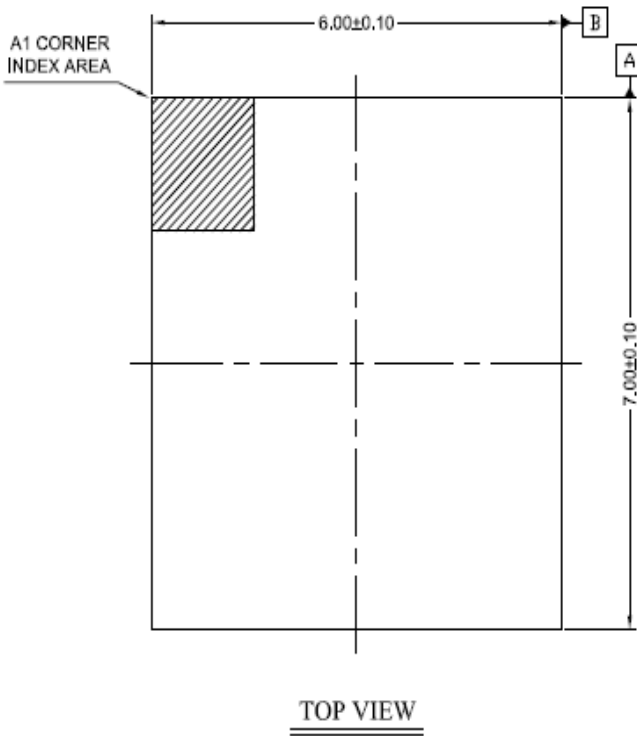

**NOTE :**

1. ALL DIMENSION ARE IN MILLIMETERS.
2.  $\Delta$  POST REFLOW SOLDER BALL DIAMETER.  
(Pre Reflow Diameter :  $0.35 \pm 0.02$ )
3.  $\Delta$  TOLERANCE INCLUDES WARPAGE.