

AS22 Series Miniature Kit Encoder



Description

The Broadcom[®] AS22 Series kit encoder solution offers a compact size with an overall diameter of 22 mm and height of 10.9 mm for the space-constrained application.

To meet the growing demand for high-precision application, the AS22 Series offers a wide range of incremental resolution, ranging from 360 to 2048 counts per revolution (cpr).

The encoder provides A and B channel of incremental digital signal output, as well as a digital index pulse per revolution enabling the homing positioning operation. The three-channel solution comes with the optional RS422 compatible differential output offering the high transmission noise immunity for signal over cable.

To cater to a wide selection of industrial applications, this encoder is design to operate in a robust environment with the operating temperature ranging from -20°C to $+100^{\circ}\text{C}$.

The AS22 Series is designed for ease of use. The kit solution is engineered with the hassle-free installation, eliminating the need for a tedious alignment process.

Features

- Compact size $\text{Ø}22 \times 10.9$ mm
- 5V operating voltage
- -20°C to $+100^{\circ}\text{C}$ operating temperature
- Incremental A, B, and Index channels
- TTL and RS422 compatible differential output
- 360 cpr to 2048 cpr
- Shaft diameter from 2 mm up to $\frac{1}{4}$ "
- Spatial play tolerance of $\text{Ø}0.15$ mm
- Allows motor shaft axial play of ± 0.25 mm
- Hassles-free installation
- Rohs compliance

Applications

- Industrial automation and robotic
- Industrial sewing and textiles machinery
- Stepper/servo motor
- Factory automation

NOTE: This product is not specifically designed or manufactured for use in any specific device. Customers are solely responsible for determining the suitability of this product for its intended application and solely liable for all loss, damage, expense, or liability in connection with such use.

Package Dimensions

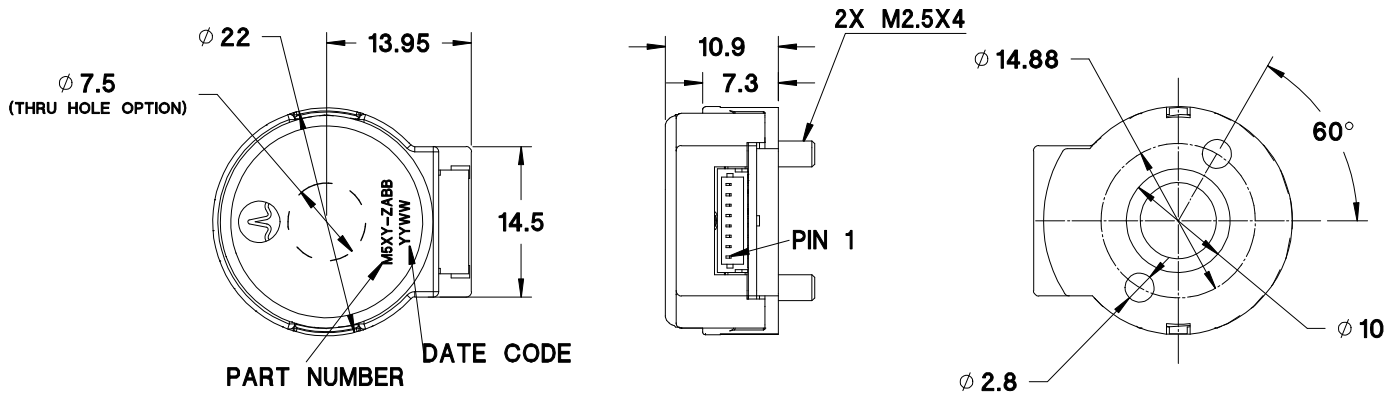

Mounting Considerations

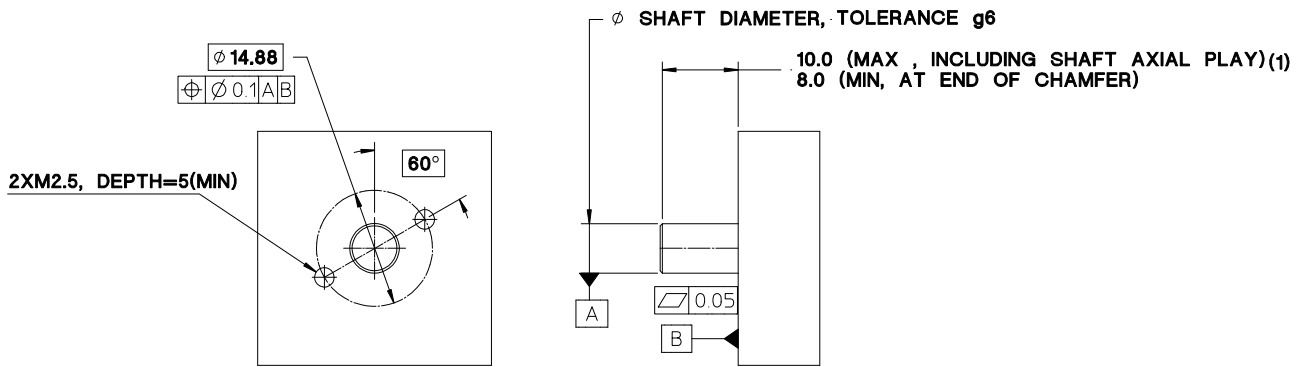

All dimensions are in mm.

NOTE: 1. No maximum shaft length limit for cover with hole option.

Pin Configuration

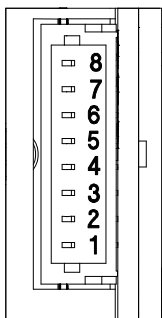

Pin	Differential	Single Ended (TTL)
1	GND	GND
2	Ch A+	Ch A+
3	Ch A-	NA
4	Vcc	Vcc
5	Ch B+	Ch B+
6	Ch B-	NA
7 ^a	Ch I+	Ch I+
8 ^a	Ch I-	NA

a. Only applicable to 3 channel options.

NOTE: Mating connector is JST Socket 08SR-3S, wire AWG #30 or JST SHR-08V-S-B/SHR-08V-S with contact SSH-003T-P0.2-H for wire AWG#32~28 .

Absolute Maximum Ratings

Parameter	
Storage Temperature, T_S	-40°C to +100°C
Operating Temperature, T_A	-20°C to +100°C
Supply Voltage, V_{CC}	-0.5V to +7V
Output Voltage, V_O	-0.5V to V_{CC}
Output Current per Channel, I_{OUT} (single ended)	±1.5 mA
Output Current per Channel, I_{OUT} (differential line drivers)	±20 mA
Vibration (JEDEC JESD22-B103)	20G, 20 Hz to 2000 Hz
Mechanical Shock (JEDEC JESD22-B110)	1500G (peak), 0.5-ms pulse duration, half sine
Relative Humidity	60°C, 90%RH
ESD, IEC 61000-4-2, Air discharge (TTL and differential)	±15 kV

Output Waveform

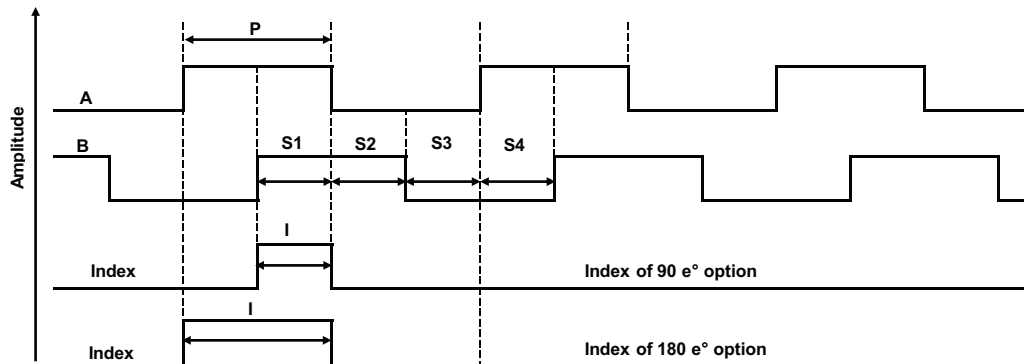

Ch A leads Ch B for clockwise direction, viewed from cover side of the encoder

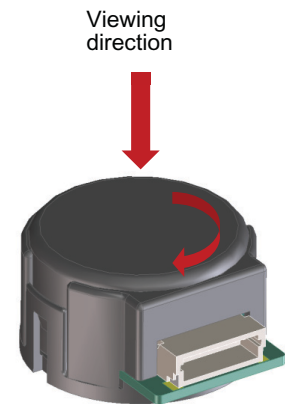

Recommended Operating Conditions

Parameter	Sym.	Min.	Typ.	Max.	Unit	Notes
Ambient Temperature	T_A	-20	—	+100	°C	
Supply Voltage	V_{CC}	4.5	5.0	5.5	V	Ripple < 100 mVp-p
Max RPM		—	—	4800k/cpr		360 cpr to 512 cpr
				9600k/cpr		1000 cpr and 1024 cpr
				19200k/cpr		2000 cpr and 2048 cpr

Encoding Characteristics

Encoding characteristics over recommended operating range and recommended mounting tolerances unless otherwise specified.

Parameter	Sym.	Min.	Typ.	Max.	Unit	Notes
Pulse Width Error	ΔP	—	10	20	°e	360 cpr to 512 cpr
		—	15	25	°e	1000 cpr and 1024 cpr
		—	20	45	°e	2000 cpr and 2048 cpr
Logic State Width Error	ΔS	—	5	15	°e	360 cpr to 512 cpr
		—	10	25	°e	1000 cpr and 1024 cpr
		—	15	40	°e	2000 cpr and 2048 cpr
Index Width Error	ΔI	—	5	40	°e	180°e index
		—	5	15	°e	90°e index

Single-Ended Electrical Characteristics

Electrical characteristics over recommended operating condition at 25°C.

Parameter	Sym.	Min.	Typ.	Max.	Unit	Notes
Supply Current	I_{CC}	—	23	35	mA	No load
High Level Output Voltage	V_{OH}	2.4	—	—	V	$I_{OH} = -1.5mA$
Low Level Output Voltage	V_{OL}	—	—	0.4	V	$I_{OL} = +1.5mA$
Output Current per Channel	I_O	—	—	1.5	mA	
Rise Time	t_r	—	<100	—	ns	$C_L = 25 pF$
Fall Time	t_f	—	<100	—	ns	$R_L = 2.7 k\Omega$
Rise Time	t_r	—	<65	—	ns	No load
Fall Time	t_f	—	<90	—	ns	

Differential Electrical Characteristics

Electrical characteristics over recommended operating condition at 25°C.

Parameter	Sym.	Min.	Typ.	Max.	Unit	Notes
Supply Current	I_{CC}	—	35	60	mA	No load
High Level Output Voltage	V_{OH}	2.4	—	—	V	$I_{OH} = -20$ mA
Low Level Output Voltage	V_{OL}	—	—	0.4	V	$I_{OL} = +20$ mA
Output Current per Channel	I_O	—	—	20	mA	
Rise Time	t_r	—	<220	—	ns	$C_L = 14$ pF
Fall Time	t_f	—	<150	—	ns	$R_L = 2.7$ k Ω
Rise Time	t_r	—	<35	—	ns	No load
Fall Time	t_f	—	<25	—	ns	

Mechanical Characteristics

Parameter	Remark	Dimension	Tolerance	Unit
Code Wheel Shaft Diameter		2, 3, 4, 5, 6	g6	mm
		1/8, 5/32, 3/16, 1/4		in.
Max Shaft Length ^a	Including shaft axial play	10(0.395)	—	mm
Min Shaft Length	End of shaft chamfer	8.0(0.315)	—	mm
Shaft Axial Play		—	± 0.25 (± 0.01)	mm (in.)
Radial Play Including Shaft TIR		—	$\varnothing 0.15$ (0.006)	mm (in.)
Max Moment of Inertia for Code Wheel Assembly		81.5	—	g.mm ²
Hub Set Screw Torque		0.10 to 0.13	—	N.m
Mounting Screw Torque (2x M2.5)		0.10 to 0.23	—	N.m

a. No limit for hole in cover option.

Ordering Information

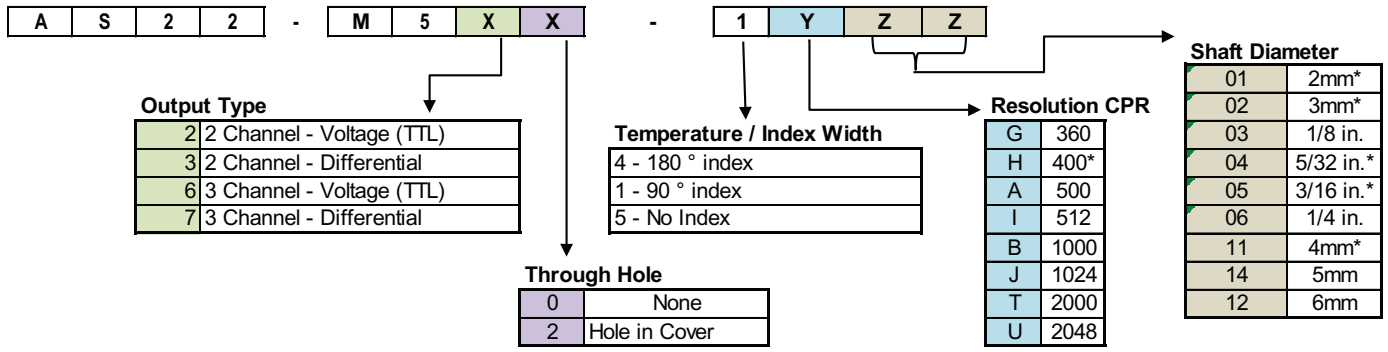

* Check with Factory for availability