

Parallel Persistent SRAM Memory

(AS3001316, AS3004316, AS3008316, AS3016316, AS3032316)

Features

- Interface
 - Parallel Asynchronous x16
- Technology
 - 40nm pMTJ STT-MRAM
 - Virtually unlimited Endurance and Data Retention (see Endurance and Data Retention on page 24)
- Density
 - 1Mb, 4Mb, 8Mb, 16Mb, 32Mb
- Operating Voltage Range
 - V_{CC} : 2.70V – 3.60V
- Operating Temperature Range
 - Industrial: -40°C to 85°C
 - Industrial Plus: -40°C to 105°C
- RoHS Compliant
- Packages
 - 44-pin TSOP (10mm x 18mm)
 - 54-pin TSOP (10mm x 22mm)
 - 48-ball FBGA (10mm x 10mm)
- Memory Array Organization
 - 1Mbit
 - 65,536 x 16
 - 4Mbit
 - 262,144 x 16
 - 8Mbit
 - 524,288 x 16
 - 16Mbit
 - 1,048,576 x 16
 - 32Mbit
 - 2,097,152 x 16

Performance

Device Operation	Typical Values	Units
Read Cycle Time	35.0 (minimum)	ns
Write Cycle Time	35.0 (minimum)	ns
Standby Current	1.7 (typical)*	mA
Sleep Mode Current	5.0 (typical)*	uA
Read Current	20.0 (typical)	mA
Write Current	20.0 (typical)	mA

*Number shown is for 16Mb device

Table of Contents

Features.....	1
Performance.....	1
Table of Contents.....	2
General Description.....	3
Ordering Options.....	4
Valid Combinations — Standard.....	5
Signal Description and Assignment.....	8
Package Options.....	9
44-Pin TSOP (Top View).....	9
54-Pin TSOP (Top View).....	9
48-Ball FBGA (Balls Down, Top View).....	10
Package Drawings.....	11
44-Pin TSOP.....	11
54-Pin TSOP.....	12
48-Ball FBGA.....	13
Architecture.....	14
Device Initialization.....	15
Electrical Specifications.....	18
Write Operation.....	20
Bus Turnaround Operation – Read to Write.....	22
Read Operation.....	23
Endurance and Data Retention.....	24
Thermal Resistance.....	25
Product Use Limitations.....	26
Limited Warranty.....	26

General Description

AS3xxx316 is a magneto-resistive random-access memory (MRAM). It is offered in density ranging from 1Mbit to 32Mbit. MRAM technology is analogous to Flash technology with SRAM compatible 35ns/35ns read/write timings (Persistent SRAM, P-SRAM). Data is always non-volatile. This makes MRAM a very reliable and fast non-volatile memory solution.

Table 1: Technology Comparison

	SRAM	Flash	EEPROM	MRAM
Non-Volatility	–	√	√	√
Write Performance	√	–	–	√
Read Performance	√	–	–	√
Endurance	√	–	–	√
Power	–	–	–	√

MRAM is a true random-access memory; allowing both reads and writes to occur randomly in memory. MRAM is ideal for applications that must store and retrieve data without incurring large latency penalties. It offers low latency, low power, virtually unlimited endurance and data retention, high performance and scalable memory technology.

AS3xxx316 is available in small footprint 54-pin TSOP (10mm x 22mm) and 48-Ball FBGA (10mm x 10mm) packages supporting densities ranging from 1Mb to 32Mb. Densities of 1Mb and 4Mb are also available in a small footprint 44-pin TSOP (10mm x 18mm). These packages are compatible with similar low-power volatile and non-volatile products.

AS3xxx316 is offered with industrial (-40°C to 85°C) and industrial plus (-40°C to 105°C) operating temperature ranges.

Ordering Options

The ordering part numbers are formed by a valid combination of the following options:

Figure 1: Part Number Ordering System

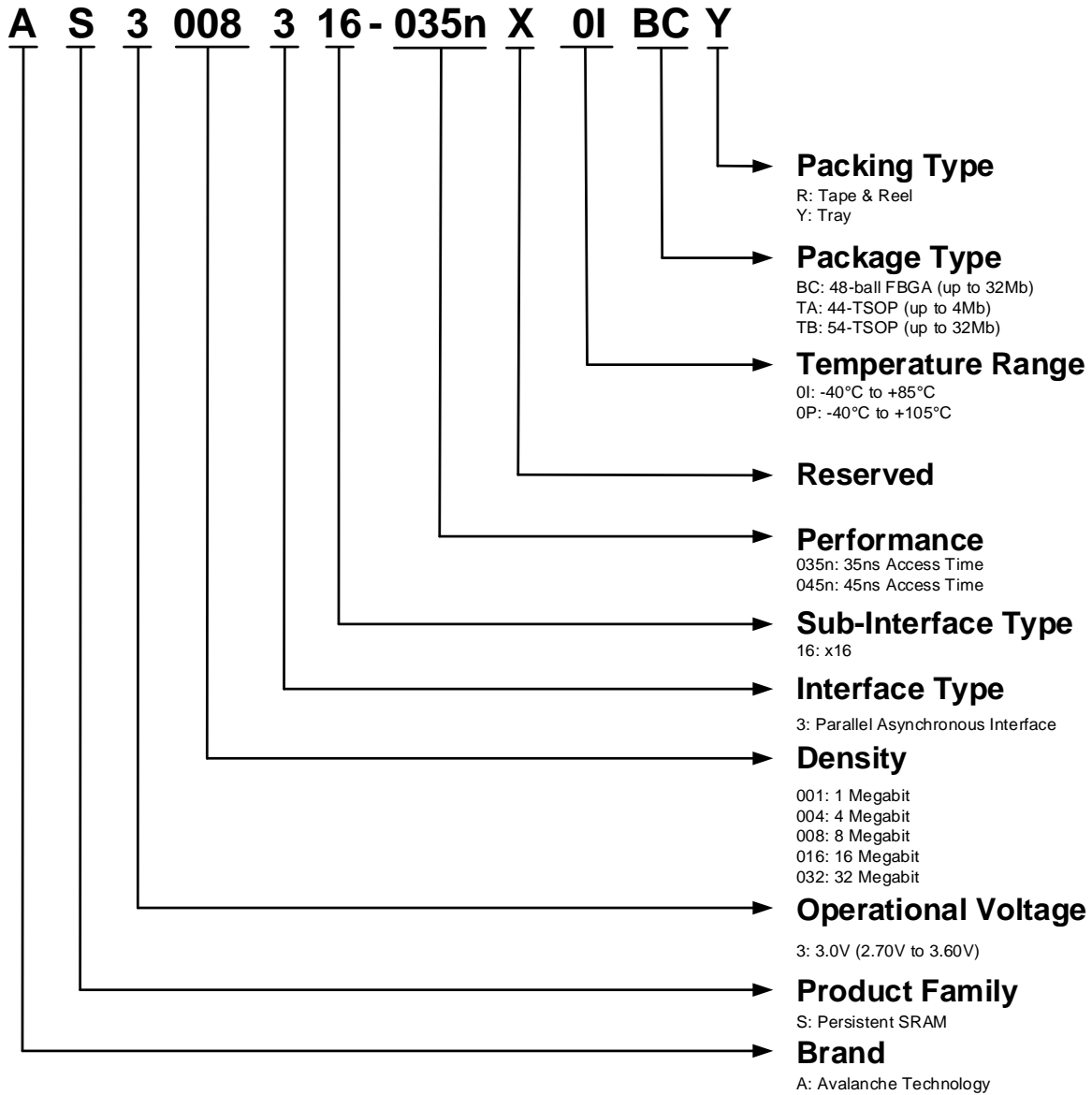

Valid Combinations — Standard

Valid Combinations list includes device configurations currently available. Contact your local sales office to confirm availability of specific valid combinations and to check on newly released combinations.

Table 2: Valid Combinations List

Valid Combinations – 35ns				
Base Part Number	Temperature Range	Package Type	Packing Type	Part Number
AS3001316-035nX	0I, 0P	BC, TA, TB	R, Y	AS3001316-035nX0IBCR
				AS3001316-035nX0IBCY
				AS3001316-035nX0ITAR
				AS3001316-035nX0ITAY
				AS3001316-035nX0ITBR
				AS3001316-035nX0ITBY
				AS3001316-035nX0PBCR
				AS3001316-035nX0PBCY
				AS3001316-035nX0PTAR
				AS3001316-035nX0PTAY
				AS3001316-035nX0PTBR
				AS3001316-035nX0PTBY
AS3004316-035nX	0I, 0P	BC, TA, TB	R, Y	AS3004316-035nX0IBCR
				AS3004316-035nX0IBCY
				AS3004316-035nX0ITAR
				AS3004316-035nX0ITAY
				AS3004316-035nX0ITBR
				AS3004316-035nX0ITBY
				AS3004316-035nX0PBCR
				AS3004316-035nX0PBCY
				AS3004316-035nX0PTAR
				AS3004316-035nX0PTAY
				AS3004316-035nX0PTBR
				AS3004316-035nX0PTBY
AS3008316-035nX	0I, 0P	BC, TB	R, Y	AS3008316-035nX0IBCR
				AS3008316-035nX0IBCY
				AS3008316-035nX0ITBR
				AS3008316-035nX0ITBY
				AS3008316-035nX0PBCR
				AS3008316-035nX0PBCY
				AS3008316-035nX0PTBR
				AS3008316-035nX0PTBY
AS3016316-035nX	0I, 0P	BC, TB	R, Y	AS3016316-035nX0IBCR
				AS3016316-035nX0IBCY

				AS3016316-035nX0ITBR
				AS3016316-035nX0ITBY
				AS3016316-035nX0PBCR
				AS3016316-035nX0PBCY
				AS3016316-035nX0PTBR
				AS3016316-035nX0PTBY
AS3032316-035nX	0I, 0P	BC, TB	R, Y	AS3032316-035nX0IBCR
				AS3032316-035nX0IBCY
				AS3032316-035nX0ITBR
				AS3032316-035nX0ITBY
				AS3032316-035nX0PBCR
				AS3032316-035nX0PBCY
				AS3032316-035nX0PTBR
				AS3032316-035nX0PTBY

Valid Combinations – 45ns				
Base Part Number	Temperature Range	Package Type	Packing Type	Part Number
AS3001316-045nX	0I, 0P	BC, TA, TB	R, Y	AS3001316-045nX0IBCR
				AS3001316-045nX0IBCY
				AS3001316-045nX0ITAR
				AS3001316-045nX0ITAY
				AS3001316-045nX0ITBR
				AS3001316-045nX0ITBY
				AS3001316-045nX0PBCR
				AS3001316-045nX0PBCY
				AS3001316-045nX0PTAR
				AS3001316-045nX0PTAY
				AS3001316-045nX0PTBR
				AS3001316-045nX0PTBY
AS3004316-045nX	0I, 0P	BC, TA, TB	R, Y	AS3004316-045nX0IBCR
				AS3004316-045nX0IBCY
				AS3004316-045nX0ITAR
				AS3004316-045nX0ITAY
				AS3004316-045nX0ITBR
				AS3004316-045nX0ITBY
				AS3004316-045nX0PBCR
				AS3004316-045nX0PBCY
				AS3004316-045nX0PTAR
				AS3004316-045nX0PTAY
AS3004316-045nX0PTBR				

AS3008316-045nX	0I, 0P	BC, TB	R, Y	AS3004316-045nX0PTBY
				AS3008316-045nX0IBCR
				AS3008316-045nX0IBCY
				AS3008316-045nX0ITBR
				AS3008316-045nX0ITBY
				AS3008316-045nX0PBCR
				AS3008316-045nX0PBCY
				AS3008316-045nX0PTBR
				AS3008316-045nX0PTBY
AS3016316-045nX	0I, 0P	BC, TB	R, Y	AS3016316-045nX0IBCR
				AS3016316-045nX0IBCY
				AS3016316-045nX0ITBR
				AS3016316-045nX0ITBY
				AS3016316-045nX0PBCR
				AS3016316-045nX0PBCY
				AS3016316-045nX0PTBR
				AS3016316-045nX0PTBY
				AS3032316-045nX
AS3032316-045nX0IBCY				
AS3032316-045nX0ITBR				
AS3032316-045nX0ITBY				
AS3032316-045nX0PBCR				
AS3032316-045nX0PBCY				
AS3032316-045nX0PTBR				
AS3032316-045nX0PTBY				

Signal Description and Assignment

Figure 2: Device Pinout

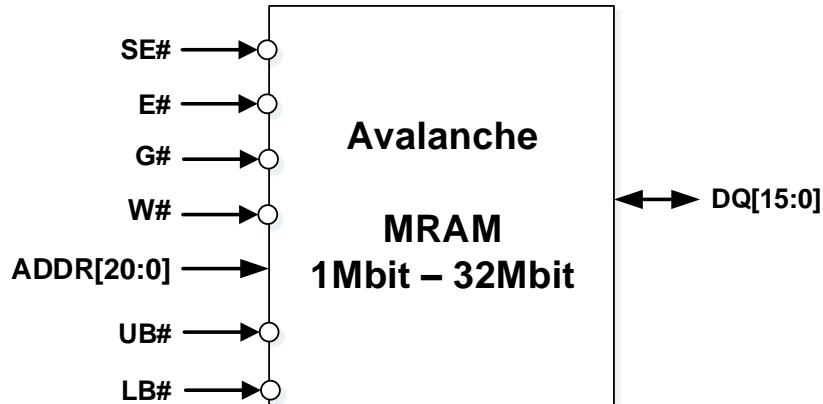
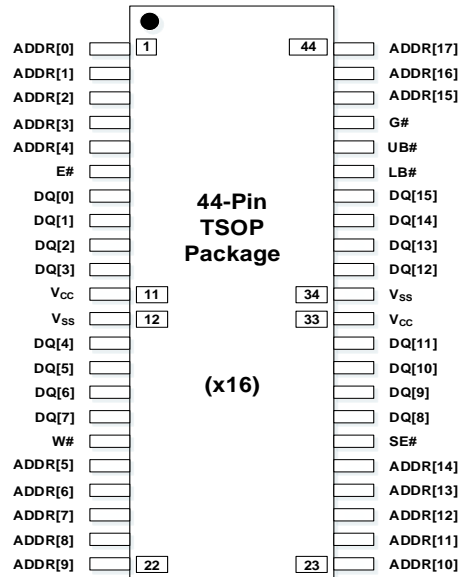

Table 3: Signal Description

Signal	Type	Description
SE#	Input	Sleep: Enables or disables Low power mode.
E#	Input	Chip enable: Enables or disables the MRAM.
G#	Input	Output enable: Enables the output drivers in bidirectional data transfer I/Os.
W#	Input	Write enable: Transfers serial data from the host system to the MRAM when Low (Logic '0'). Transfers serial data from the MRAM to the host system when High (Logic '1').
UB#	Input	Upper Byte Enable: Enables or disables DQ[15:8].
LB#	Input	Lower Byte Enable: Enables or disables DQ[7:0].
ADDR[20:0]	Input	Address: I/Os for address transfer. 01M: ADDR[15:0] – 16 Address pins for 01M devices. 04M: ADDR[17:0] – 18 Address pins for 04M devices. 08M: ADDR[18:0] – 19 Address pins for 08M devices. 16M: ADDR[19:0] – 20 Address pins for 16M devices. 32M: ADDR[20:0] – 21 Address pins for 32M devices.
DQ[15:0]	Input / Output	Data inputs/outputs: The bidirectional I/Os transfer data.
V_{cc}	Supply	V_{cc}: Core and I/O power supply.
V_{ss}	Supply	V_{ss}: Core and I/O ground supply.
NC		No connect: NCs are not internally connected. They can be driven or left unconnected.
DNU		Do not use: DNUs must be left unconnected.

Package Options

44-Pin TSOP (Top View)



54-Pin TSOP (Top View)

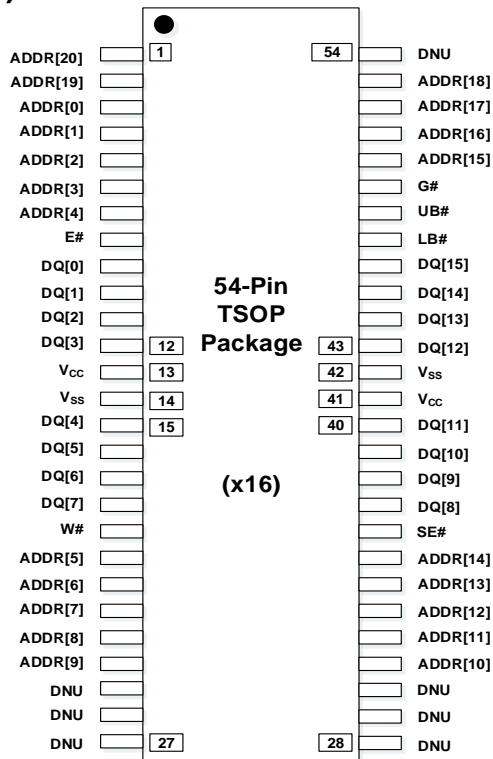

48-Ball FBGA (Balls Down, Top View)

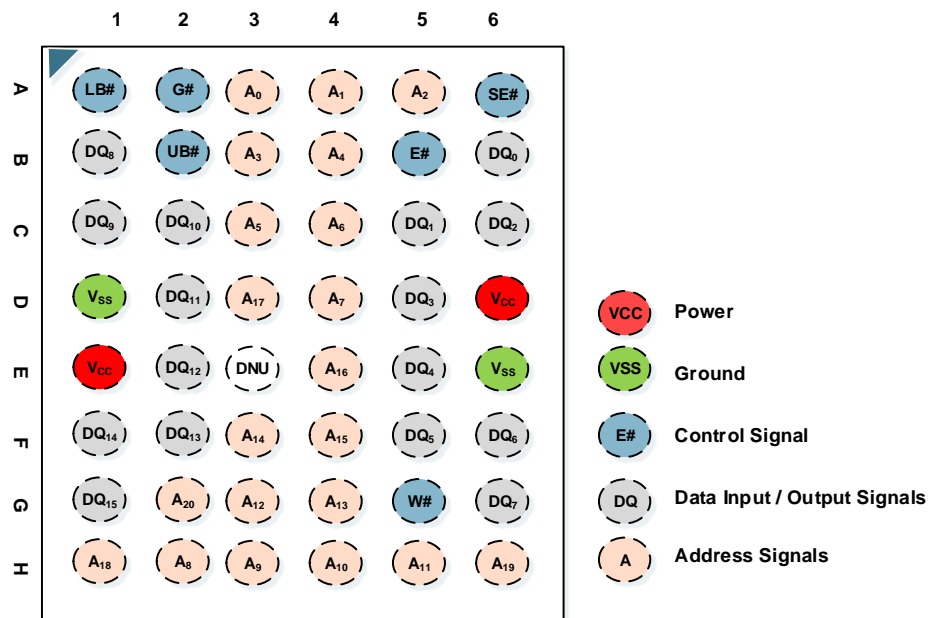

Package Drawings

44-Pin TSOP

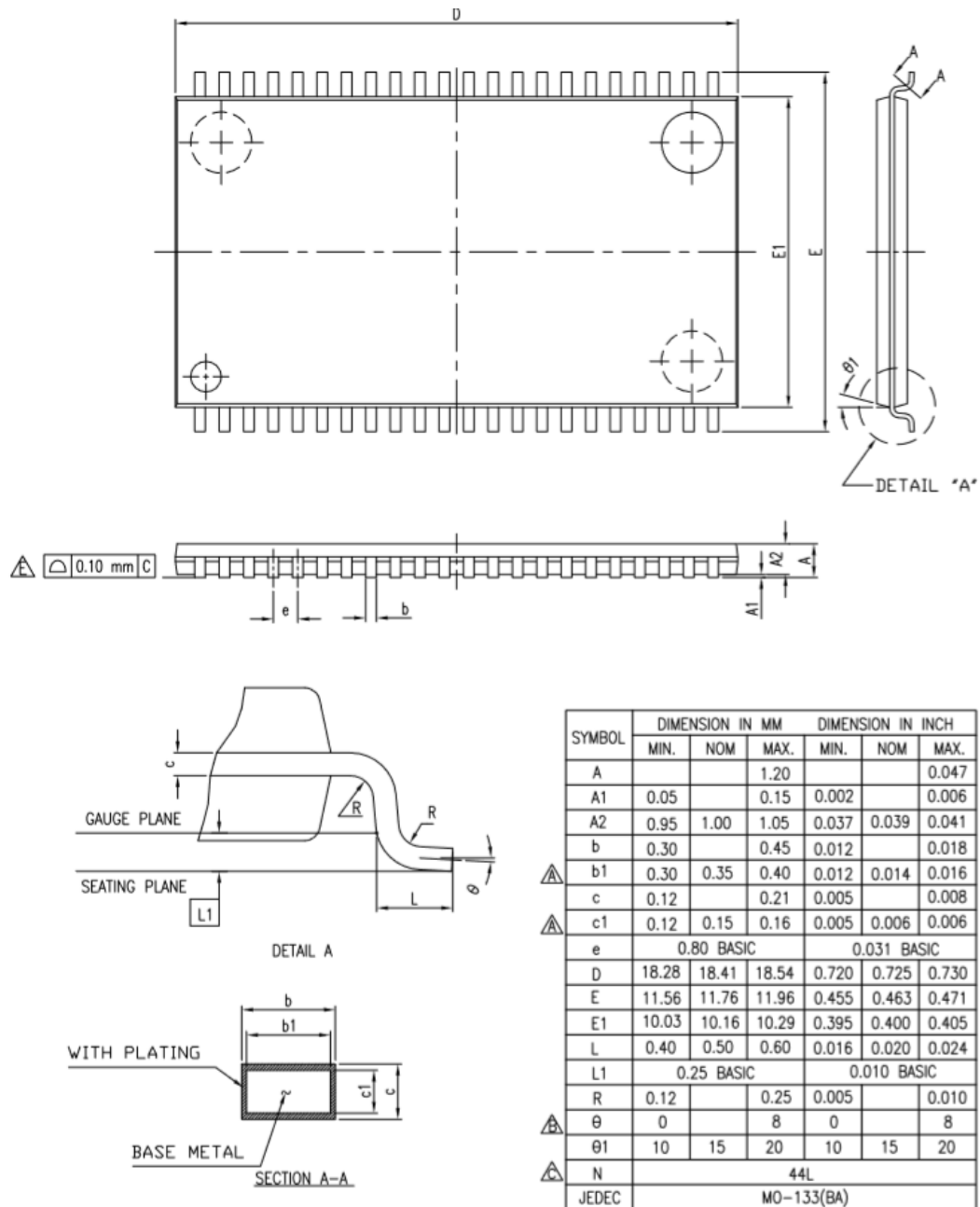

NOTE : DIMENSIONS D AND E1 DO NOT INCLUDE MOLD PROTRUSIONS.
 D AND E1 ARE MAXIMUM PLASTIC BODY SIZE DIMENSIONS INCLUDING MOLD MISMATCH.

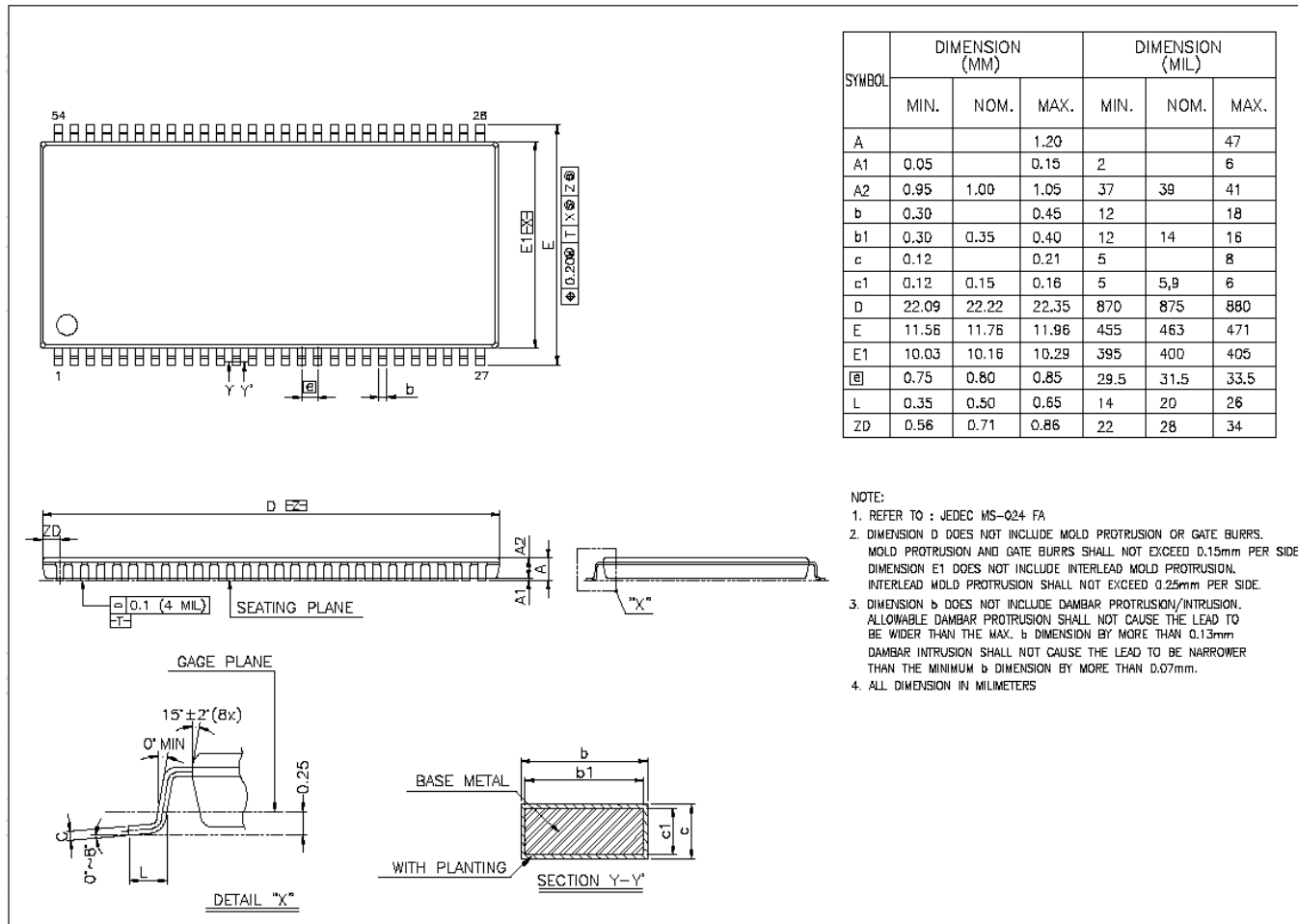
54-Pin TSOP

48-Ball FBGA

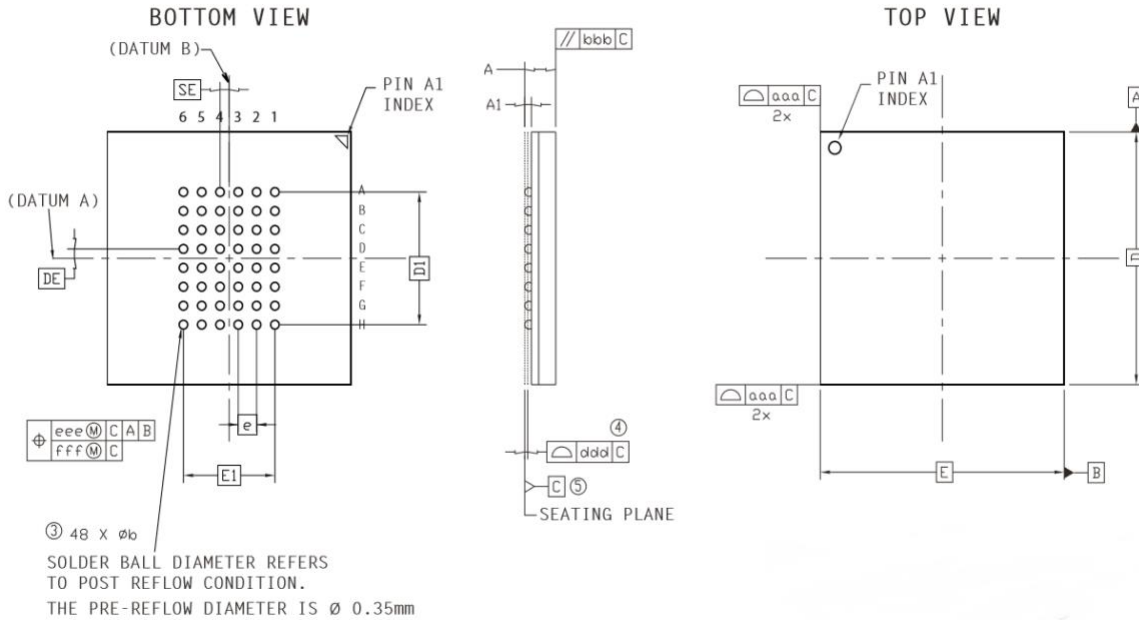

Ref	Min	Nominal	Max
A	1.19	1.27	1.35
A1	0.22	0.27	0.32
b	0.31	0.36	0.41
D	10.00 BSC		
E	10.00 BSC		
D1	5.25 BSC		
E1	3.75 BSC		
DE	0.375 BSC		
SE	0.375 BSC		
e	0.75 BSC		

Ref	Tolerance of, from and position
aaa	0.10
bbb	0.10
ddd	0.10
eee	0.15
fff	0.08

1. Dimensions in Millimeters.
2. The 'e' represents the basic solder ball grid pitch.
- ③ 'b' is measurable at the maximum solder ball diameter in a plane parallel to datum C.
- ④ Dimension 'ddd' is measured parallel to primary datum C.
- ⑤ Primary datum C (seating plane) is defined by the crowns of the solder balls.
6. Package dimensions refer to JEDEC MO-205 Rev. G.

Architecture

AS3xxx316 is a high performance MRAM device. Writing to and reading from the device as follows:

To write to the device, bring Chip Enable (E#) and Write Enable (W#) inputs Low (Logic '0'). This enables data on I/O pins (DQ[0] to DQ[15]) to be written into the memory location specified by the address pins ADDR[0] through ADDR[20] (54-pin TSOP and 48-ball FBGA) and ADDR[0] through ADDR[17] (44-pin TSOP).

To read from the device, bring Chip Enable (E#) input Low (Logic '0'), Output Enable (G#) input Low (Logic '0') while maintaining Write Enable (W#) High (Logic '1'). This enables data from the memory location specified by the address pins ADDR[0] through ADDR[20] (54-pin TSOP and 48-ball FBGA) and ADDR[0] through ADDR[17] (44-pin TSOP) to appear on I/O pins (DQ[0] to DQ[15]).

Figure 3: Functional Block Diagram

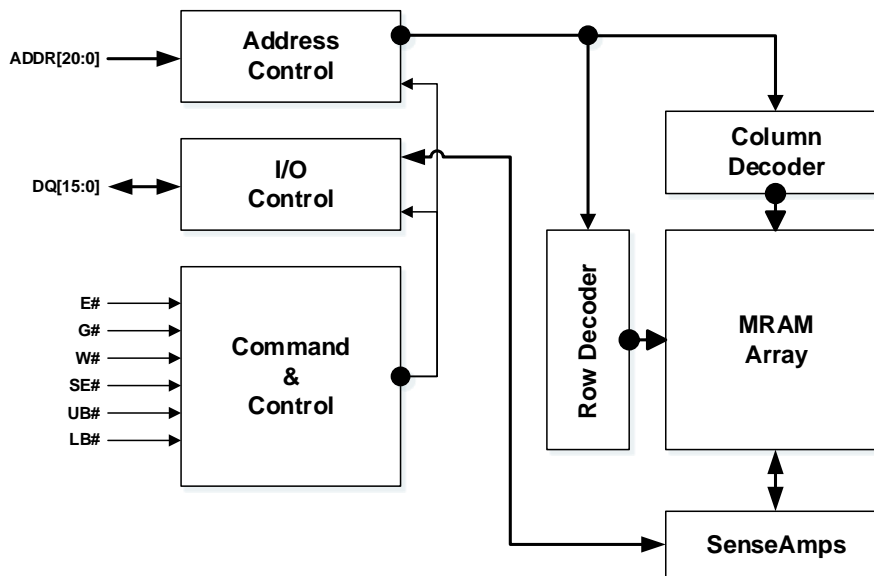

Table 4: Modes of Operation

Mode	E#	G#	W#	SE#	UB#	LB#	Current	DQ[15:8]	DQ[7:0]
Not Selected	H	X	X	H	X	X	ISB	Hi-Z	Hi-Z
Output Disabled	L	H	H	H	X	X	I _{READ}	Hi-Z	Hi-Z
Output Disabled	L	X	X	H	H	H	I _{READ}	Hi-Z	Hi-Z
Read Upper Byte	L	L	H	H	L	H	I _{READ}	Dataout	Hi-Z
Read Lower Byte	L	L	H	H	H	L	I _{READ}	Hi-Z	Dataout
Read Word	L	L	H	H	L	L	I _{READ}	Dataout	Dataout
Write Upper Byte	L	X	L	H	L	H	I _{WRITE}	Datain	Hi-Z
Write Lower Byte	L	X	L	H	H	L	I _{WRITE}	Hi-Z	Datain
Write Word	L	X	L	H	L	L	I _{WRITE}	Datain	Datain
Sleep	H	X	X	L	X	X	I _{SLP}	Hi-Z	Hi-Z

Notes:

H: High (Logic '1')

X: Don't Care

L: Low (Logic '0')

Hi-Z: High Impedance

Device Initialization

When powering up, the following procedure is required to initialize the device correctly:

- E#, W#, G#, SE# must follow V_{CC} during power-up

Figure 4: Power-Up Behavior

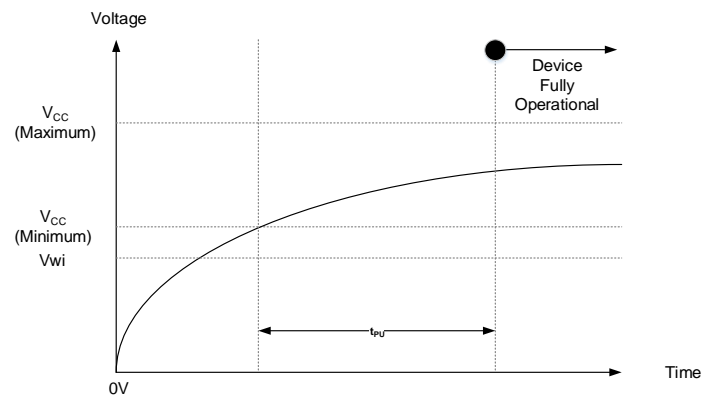

When powering down, the following procedure is required to turn off the device correctly:

- E#, W#, G#, SE# must follow V_{CC} during power-down
- During power loss or brownout, where V_{CC} goes below V_{wi} , read/write operations are prohibited. The power-up timing needs to be observed after V_{CC} goes above V_{CC} (minimum)

Figure 5: Power-Down Behavior

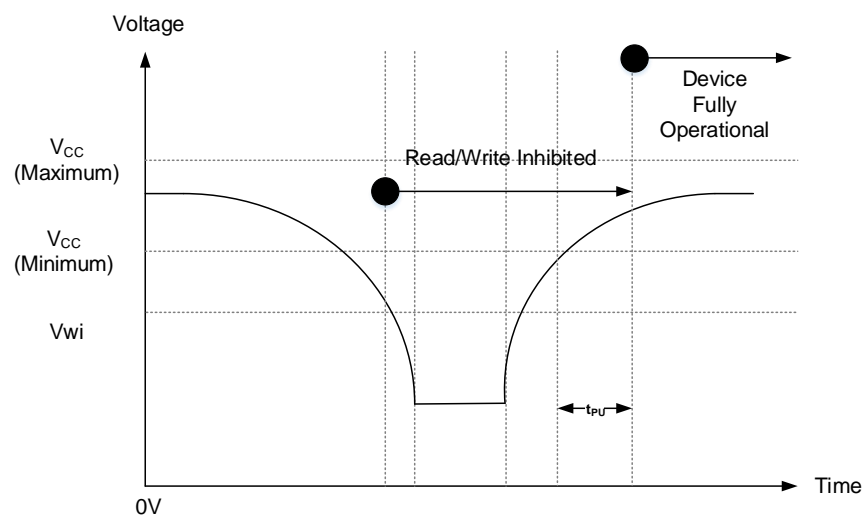

Sleep Mode - The device incorporate a sleep mode of operation to achieve lowest power supply current condition

- The device enters the sleep mode by asserting the SE# pin low. Read and Write operation must be completed before the SE# pin going low.
- When SE# is asserted low, it should remain low for at least 5 μ S.
- Sleep exit is achieved by asserting the SE# pin high. There is a 5 μ S wait delay before the device is operational.
- If sleep mode is not used, the SE# pin should be tied to V_{CC} .
 - For existing designs migrating to this device, it is not required to tie this pin to V_{CC} . The pin can be left as NC. The pin has a pull-up on-chip and the device will function normally with this pin not connected.

Figure 6: Sleep Mode Timing

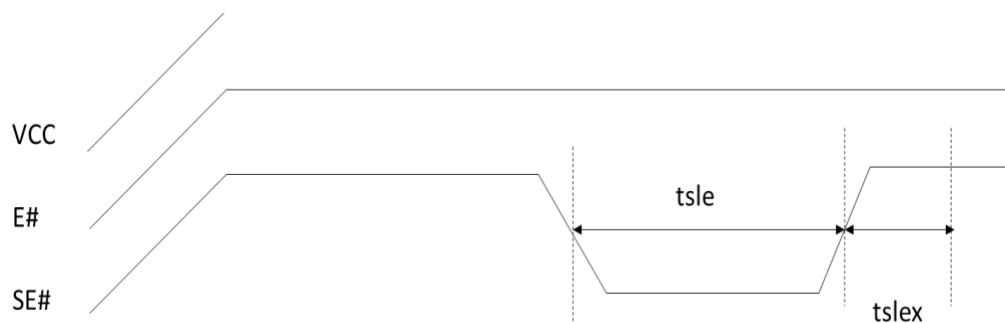

Table 5: Sleep Mode Timing

Parameter	Symbol	Minimum	Maximum	Units
Sleep Mode Entry Time	t_{sle}	5	-	μ S
Sleep Mode Exit Time	t_{slex}	5	-	μ S

Table 6: Device Initialization Timing – 3.0V

Parameter	Symbol	Test Conditions	3.0V			Units
			Minimum	Typical	Maximum	
V_{CC} Range		All operating voltages and temperatures	2.7	-	3.6	V
V_{CC} Power Up to First Instruction	t _{PU}	All operating voltages and temperatures	-	-	1	ms

Electrical Specifications

Table 7: Recommended Operating Conditions

Parameter / Condition	Minimum	Typical	Maximum	Units	
	Industrial	-40.0	-	85.0	°C
	Industrial Plus	-40.0	-	105.0	°C
V _{CC} Supply Voltage	3.0V	2.7	3.0	3.6	V
V _{SS} Supply Voltage		0.0	0.0	0.0	V
V _{wi} Write Inhibit Voltage		2.1	2.3	2.5	V

Table 8: Pin Capacitance

Parameter	Test Conditions	Symbol	Maximum	Units
Input Pin Capacitance	TEMP = 25°C; f = 1 MHz; V _{IN} = 0V	C _{IN}	10.0	pF
Input / Output Pin Capacitance	TEMP = 25°C; f = 1 MHz; V _{IN} = 0V	C _{INOUT}	10.0	pF

Table 9: DC Characteristics

Parameter	Symbol	Test Conditions	3.0V Device (2.7V-3.6V)			Units	
			Minimum	Typical	Maximum		
Read Current	I _{READ}	V _{CC} (max), I _{OUT} =0mA	-	20.0	30.0	mA	
Write Current	I _{WRITE}	V _{CC} (max)	-	20.0	30.0	mA	
Standby Current Industrial (-40°C to 85°C)	I _{SB}	E#=V _{IH} , V _{CC} (max)	1Mb-16Mb	-	1.5	1.7	mA
			32Mb	-	3.0	3.4	
Standby Current Industrial Extended (-40°C to 105°C)	I _{SB}	E#=V _{IH} , V _{CC} (max)	1Mb-16Mb	-	1.7	2.0	mA
			32Mb	-	3.4	4.0	
Sleep Mode Current	I _{SLP}	V _{CC} (max), 85°C	1Mb-16Mb	-	5.0	8.0	uA
			32Mb	-	10.0	16.0	
Input Leakage Current	I _{LI}	V _{IN} =0 to V _{CC} (max)	-	-	±1.0	μA	
Output Leakage Current	I _{LO}	V _{OUT} =0 to V _{CC} (max)	-	-	±1.0	μA	
Input High Voltage	V _{IH}		0.8xV _{CC}	-	V _{CC} +0.3	V	
Input Low Voltage	V _{IL}		-0.5	-	0.2xV _{CC}	V	
Output High Voltage Level	V _{OH}	I _{OH} = -1.6mA	V _{CC} -0.5	-	-	V	
Output Low Voltage Level	V _{OL}	I _{OL} = 1.6mA	-	-	0.4	V	

Table 10: Magnetic Immunity Characteristics

Parameter	Symbol	Maximum	Units
Magnetic Field During Write	H_{\max_write}	24000	A/m
Magnetic Field During Read	H_{\max_read}	24000	A/m

Table 11: AC Test Conditions

Parameter	Value
Input pulse levels	0.0V to V_{CC}
Input rise and fall times	5ns
Input and output measurement timing levels	$V_{CC}/2$
Output Load	CL = 30pF

Write Operation

Figure 7: Write Operation

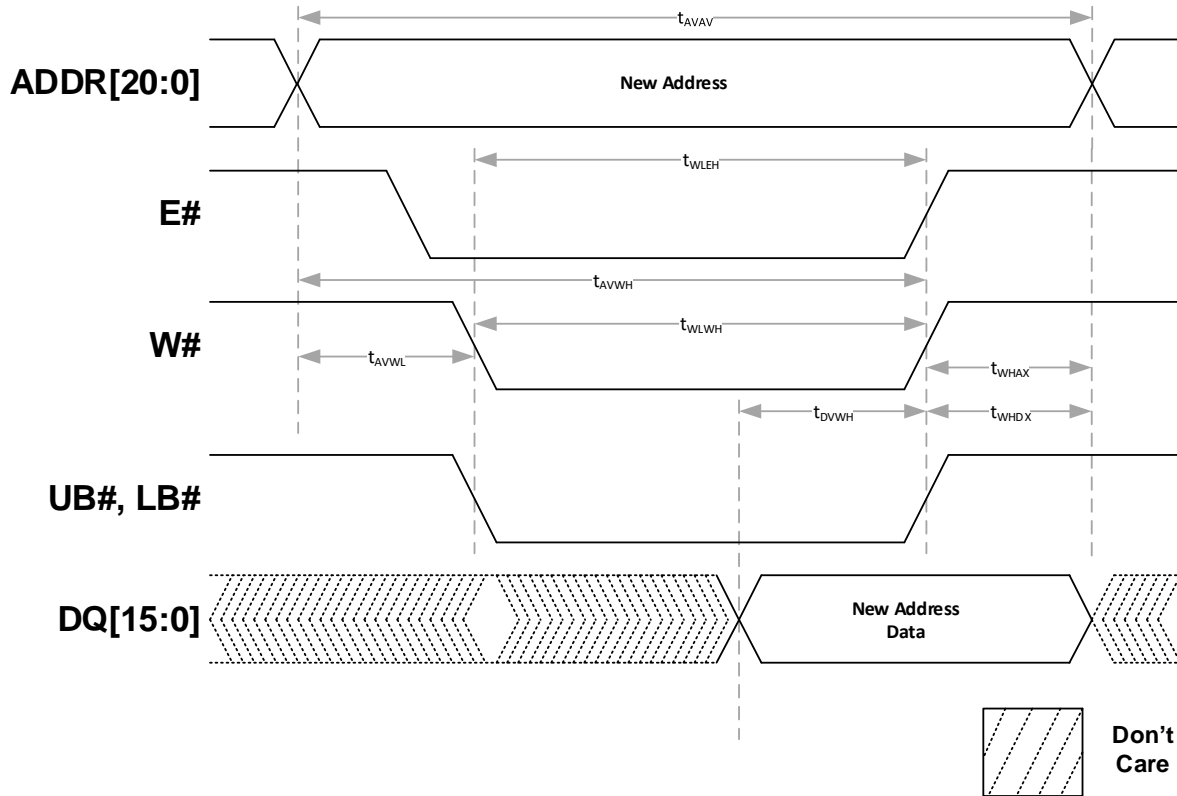

Table 12: Write Operation (W# Controlled)

Parameter	Symbol	Minimum		Maximum	Units
		35ns	45ns		
Write Cycle Time	t_{AVAV}	35	45	-	ns
Address Set-Up Time	t_{AVWL}	0		-	ns
Address Valid to end of Write (G# High)	t_{AVWH}	18	28	-	ns
Address Valid to end of Write (G# Low)	t_{AVWH}	20	30	-	ns
Write Pulse Width (G# High)	t_{WLWH}, t_{WLEH}	15	25	-	ns
Write Pulse Width (G# Low)	t_{WLWH}, t_{WLEH}	15	25	-	ns
Data Valid to end of Write	t_{DVWH}	10	15	-	ns
Data Hold Time	t_{WHDX}	0		-	ns
Write recovery Time	t_{WHAX}	12		-	ns

Notes:

- G# is High (Logic '1') for Write operation
- Power supplies must be stable
- Addresses valid either before or at the same time as E# goes low

Figure 8: Write Operation (E# Controlled)

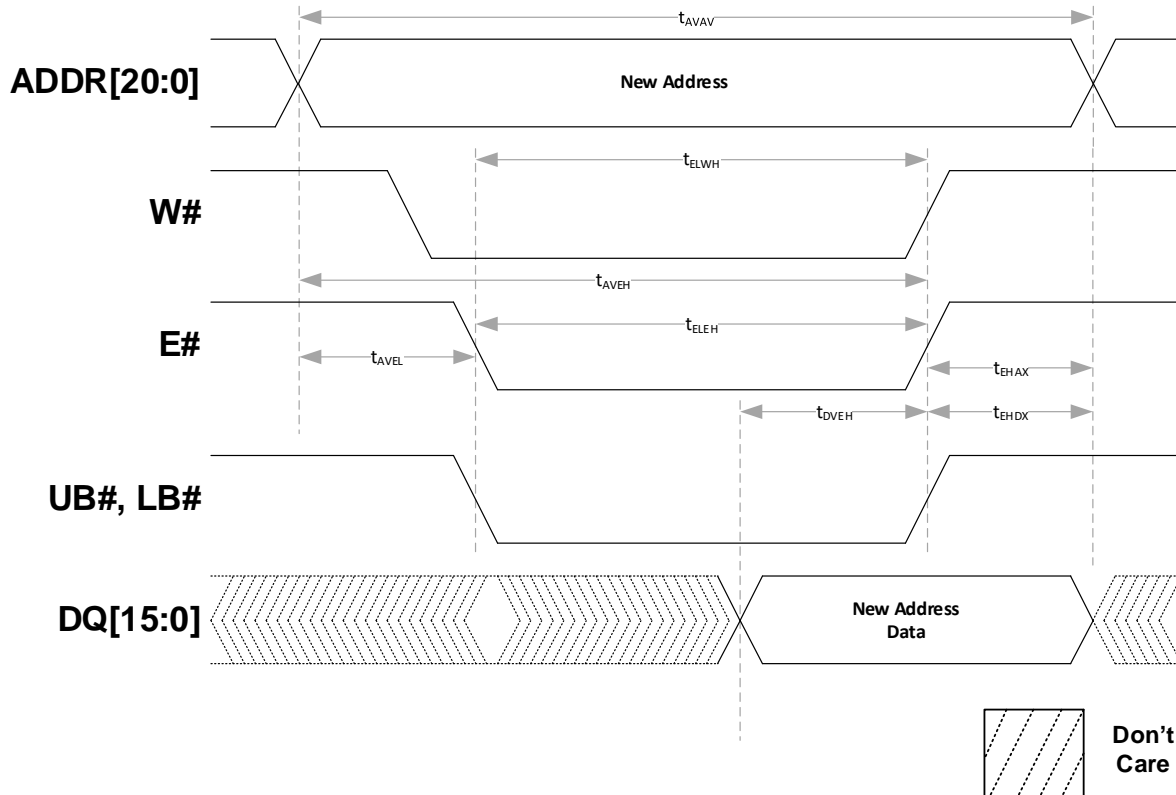

Table 13: Write Operation (E# Controlled)

Parameter	Symbol	Minimum		Maximum	Units
		35ns	45ns		
Write Cycle Time	t_{AVAV}	35	45	-	ns
Address Set-Up Time	t_{AVEL}	0		-	ns
Address Valid to end of Write (G# High)	t_{AVEH}	18	28	-	ns
Address Valid to end of Write (G# Low)	t_{AVEH}	20	30	-	ns
Write Pulse Width (G# High)	t_{ELWH}, t_{ELEH}	15	25	-	ns
Write Pulse Width (G# Low)	t_{ELWH}, t_{ELEH}	15	25	-	ns
Data Valid to end of Write	t_{DVEH}	10	15	-	ns
Data Hold Time	t_{EHDX}	0		-	ns
Write recovery Time	t_{EHAX}	12		-	ns

Notes:

G# is High (Logic '1') for Write operation

Power supplies must be stable

Addresses valid either before or at the same time as W# goes low

Bus Turnaround Operation – Read to Write

Figure 8: Bus Turnaround Operation

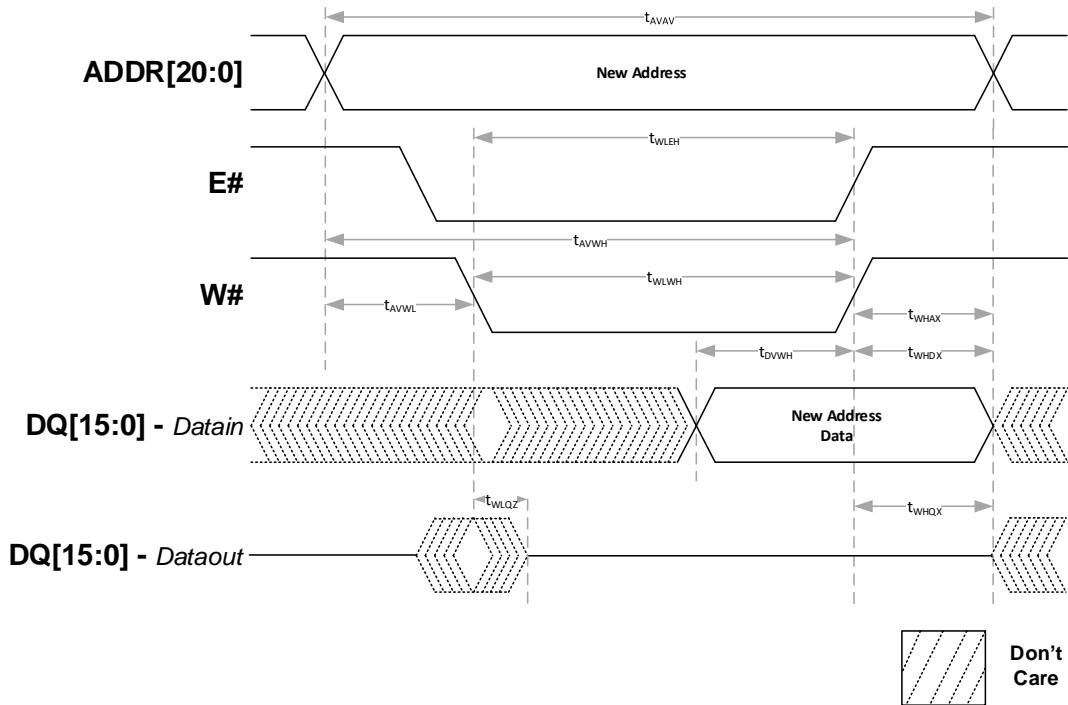

Table 14: Write Operation

Parameter	Symbol	Minimum	Maximum		Units
			35ns	45ns	
W# Low to Data Hi-Z	t_{WLQZ}	0	12	15	ns
W# High to Output Active	t_{WHQX}	3	-	-	ns

Notes:

Power supplies must be stable

Addresses valid either before or at the same time as E# goes low

Read Operation

Figure 9: Read Operation

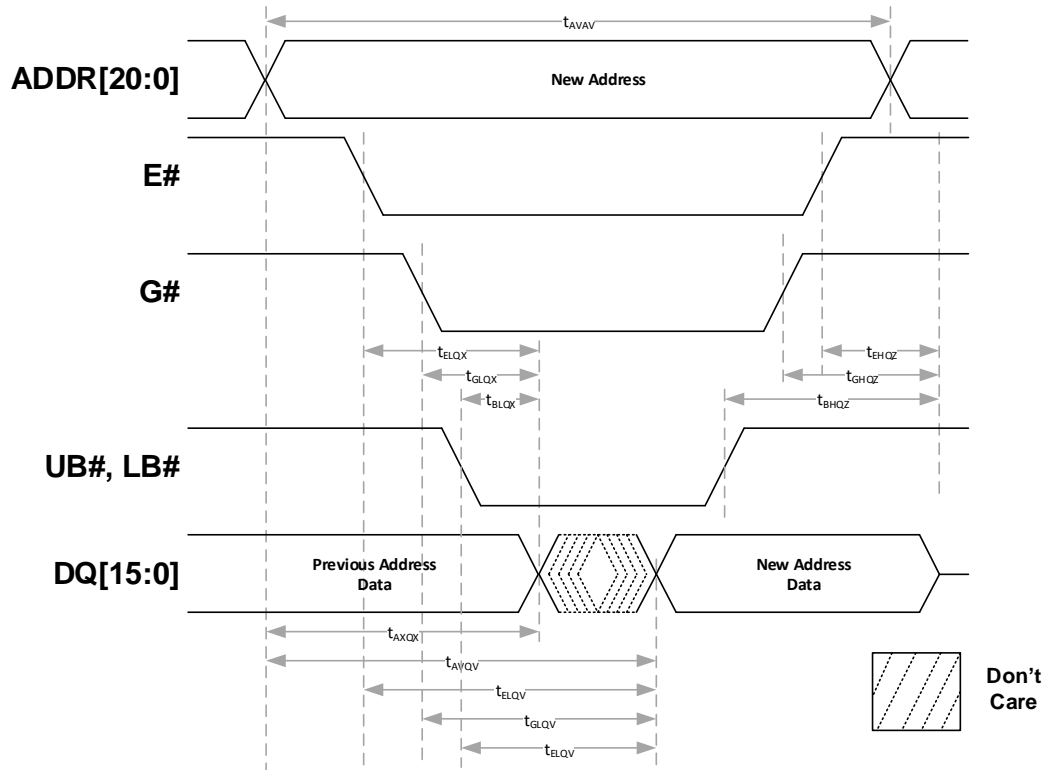

Table 15: Read Operation

Parameter	Symbol	Minimum		Maximum		Units
		35ns	45ns	35ns	45ns	
Read Cycle Time	t_{AVAV}	35	45	-	-	ns
Address Cycle Time	t_{AVQV}	-	-	35	45	ns
Chip Enable Access Time	t_{ELQV}	-	-	35	45	ns
Output Enable Access Time	t_{GLQV}	-	-	15	25	ns
Byte Enable Access Time	t_{BLQV}	-	-	15	25	ns
Output Hold From Address Change	t_{AXQX}	3	-	-	-	ns
Chip Enable Low to Output Active	t_{ELQX}	3	-	-	-	ns
Output Enable Low to Output Active	t_{GLQX}	0	-	-	-	ns
Byte Enable Low to Output Active	t_{BLQX}	0	-	-	-	ns
Chip Enable High to Output Hi-Z	t_{EHQZ}	0	-	15	-	ns
Output Enable High to Output Hi-Z	t_{GHQZ}	0	-	10	15	ns
Byte Enable High to Output Hi-Z	t_{BHQZ}	0	-	10	-	ns

Notes:

W# is High (Logic '1') for Read operation

Power supplies must be stable

Addresses valid either before or at the same time as E# goes low

Endurance and Data Retention

Table 16: Endurance and Data Retention

Parameter	Symbol	Test Conditions	Minimum	Units
Write Endurance	END	-	10 ¹⁴	cycles
Data Retention	RET	105°C	10	years
		85°C	1,000	
		75°C	10,000	
		65°C	1,000,000	

Thermal Resistance

Table 17: Thermal Resistance Specifications

Parameter	Description	Test Conditions	44-pin TSOP	54-pin TSOP (16Mb)	54-pin TSOP (32Mb)	48 Ball FBGA (16Mb)	48 Ball FBGA (32Mb)	Unit
θ_{JA}	Thermal resistance (junction to ambient)	Test conditions follow standard test methods and procedures for measuring thermal impedance, per EIA/JESD51	40.05	52.78	54.07	42.67	43.98	°C/W
θ_{JC}	Thermal resistance (junction to case)		7.02	6.70	7.82	11.09	11.82	

Notes:

1: These parameters are guaranteed by characterization; not tested in production.