



Eval Kit Manual

AS5013

Adapter Board

AS5013-QF_EK_AB

Table of Contents

1	Introduction	3
1.1	Kit Content	3
2	Board description	4
3	AS5013 adapter board and pinout	5
4	AS5013-QF_EK_AB Hardware	6
4.1	AS5013-QF_EK_AB schematics	6
4.2	AS5013-QF_EK_AB PCB layout	7
5	Ordering & Contact Information	8
6	Copyrights & Disclaimer.....	9

Revision History

Revision	Date	Owner	Description
1.0	07.01.2015	azen	Initial version

1 Introduction

The AS5013 adapter board is a small PCB allowing simple and quick testing or evaluation of the AS5013 magnetic position sensor without the need to build a test fixture or design an own PCB.

1.1 Kit Content

Figure 1: Kit content

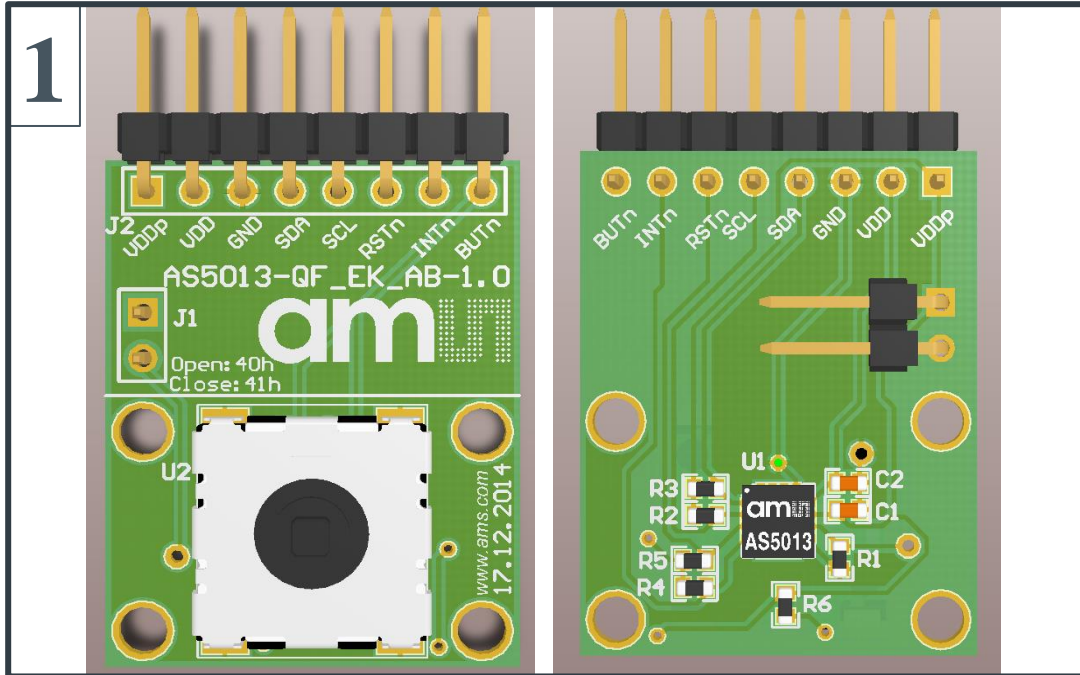

Pos.	Item	Comment
1	AS5013-QF_EK_AB	Adapter board (View front-/backside)
2	N40P107	EasyPoint Module (mounted on the adapterboard's frontside)

2 Board description

The PCB can either be connected to an external microcontroller or to the Universal Connector Board (AS5xxx-UCB) in combination with a NI USB-8451 box and our provided LabVIEW software.

J2 has to be populated with a 1x8 pin header and is required for power supply as well as I2C Interface.

The connector J1 allows to select between 40h or 41h as I2C adress.

Figure 2: AS5013 adapter board (Frontside & Backside)

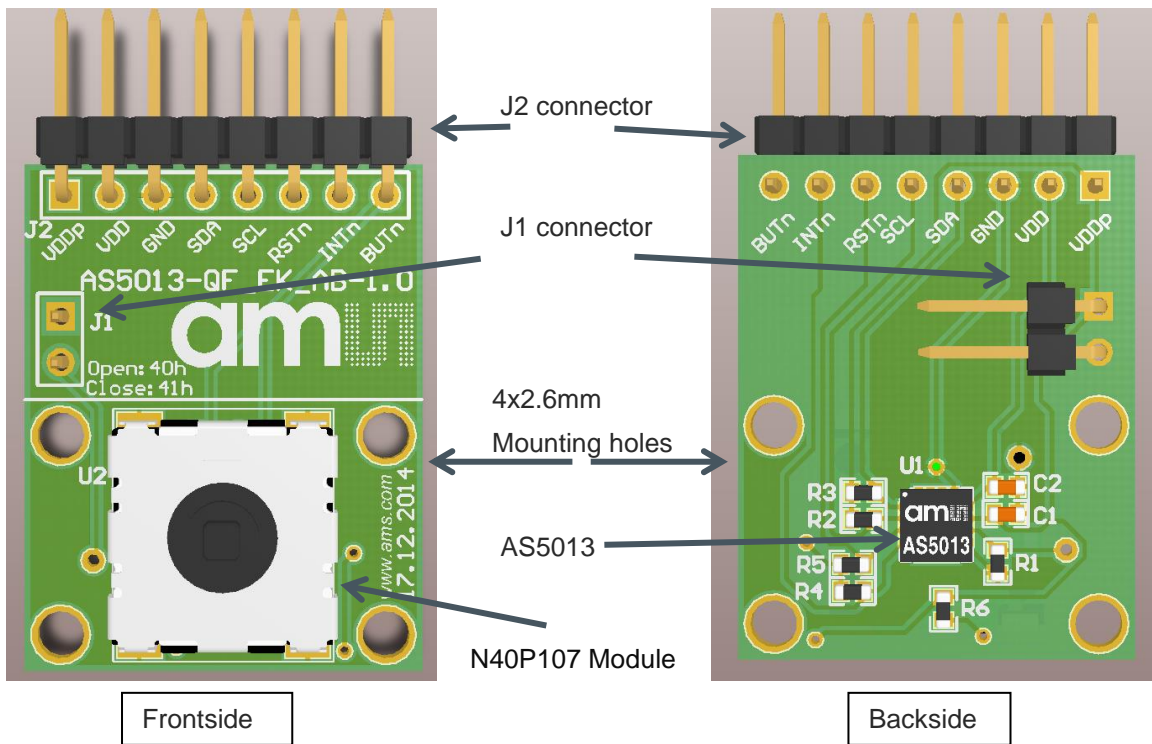

3 AS5013 adapter board and pinout

Figure 3: AS5013 adapter board and sensor pinout

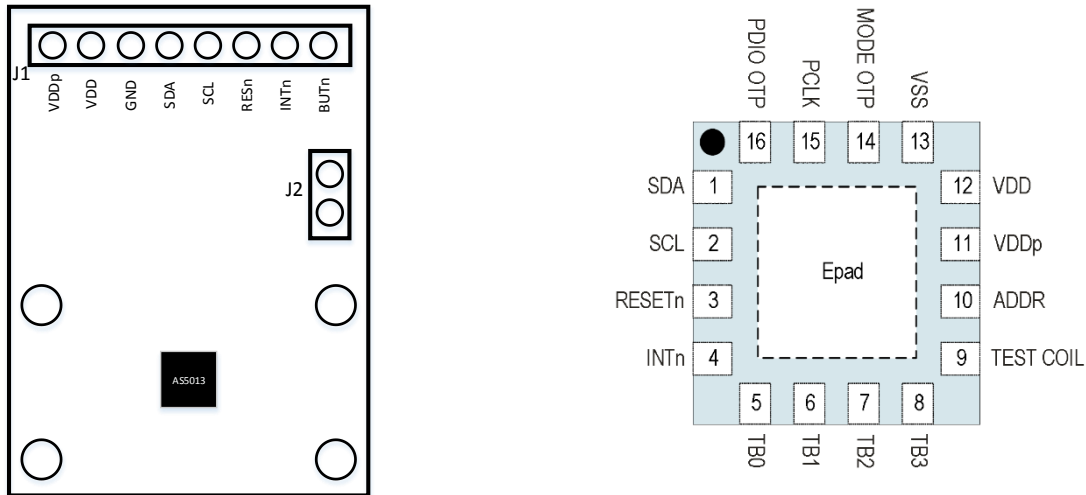

Pin# Board	Pin# AS5013	Symbol board	Type	Description
J1 - 1	11	VDDp	Power supply	I/O power supply
J1 - 2	12	VDD	Power supply	Core power supply
J1 - 3	13	GND	Power supply	Ground
J1 - 4	1	SDA	Digital in-/output	I2C Data line
J1 - 5	2	SCL	Digital input	I2C Clock line
J1 - 6	3	RESn	Digital input	SPI MOSI
J1 - 7	4	INTn	Digital output	SPI MISO
J1 - 8	-	BUTn	Digital output	Push Button functionality
-	5	TB0	Not connected	Test Pin
-	6	TB1	Not connected	Test Pin
-	7	TB2	Not connected	Test Pin
-	8	TB3	Not connected	Test Pin
-	9	TEST COIL	Not connected	Test Pin
-	10	ADDR	Not connected	I2C address selection input
-	14	MODE OTP	Not connected	Test Pin
-	15	PCLK	Not connected	Test Pin
-	16	PDIO OTP	Not connected	Test Pin

4 AS5013-QF_EK_AB Hardware

4.1 AS5013-QF_EK_AB schematics

Figure 4: AS5013-QF_EK_AB schematics

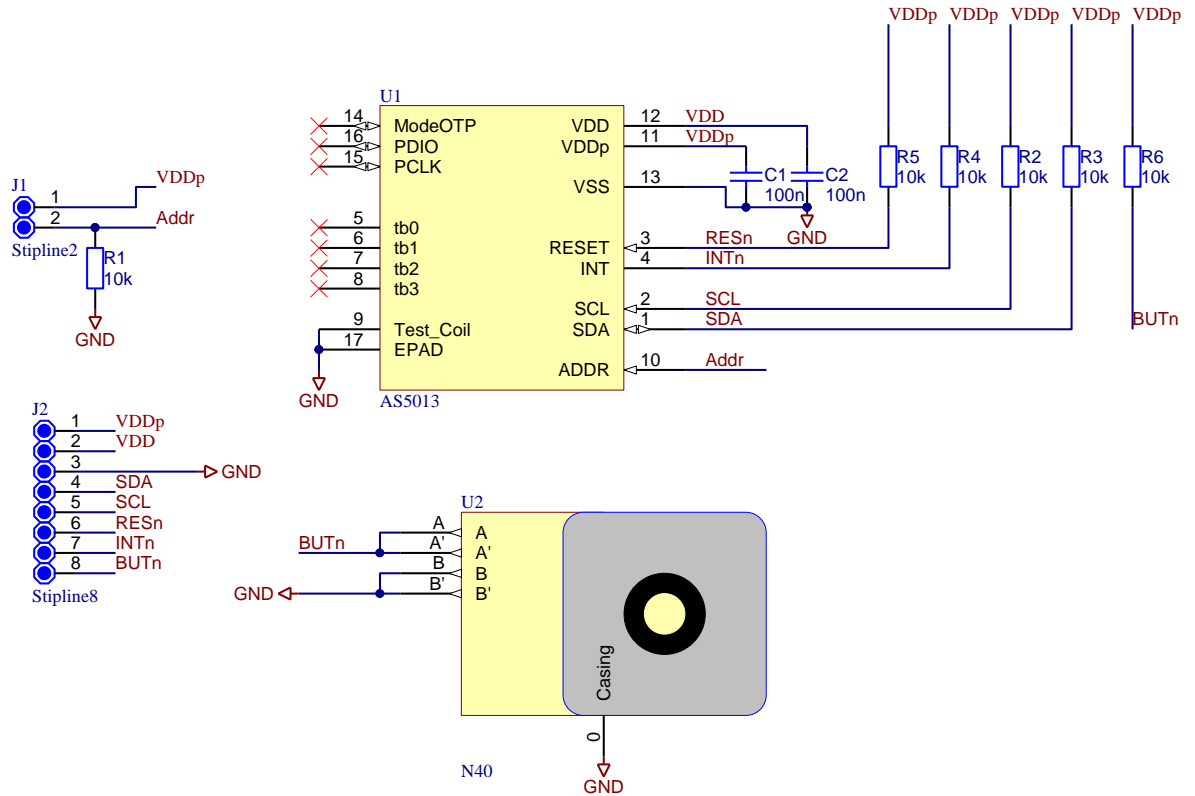

4.2 AS5013-QF_EK_AB PCB layout

Figure 5: AS5013-QF_EK_AB PCB layout

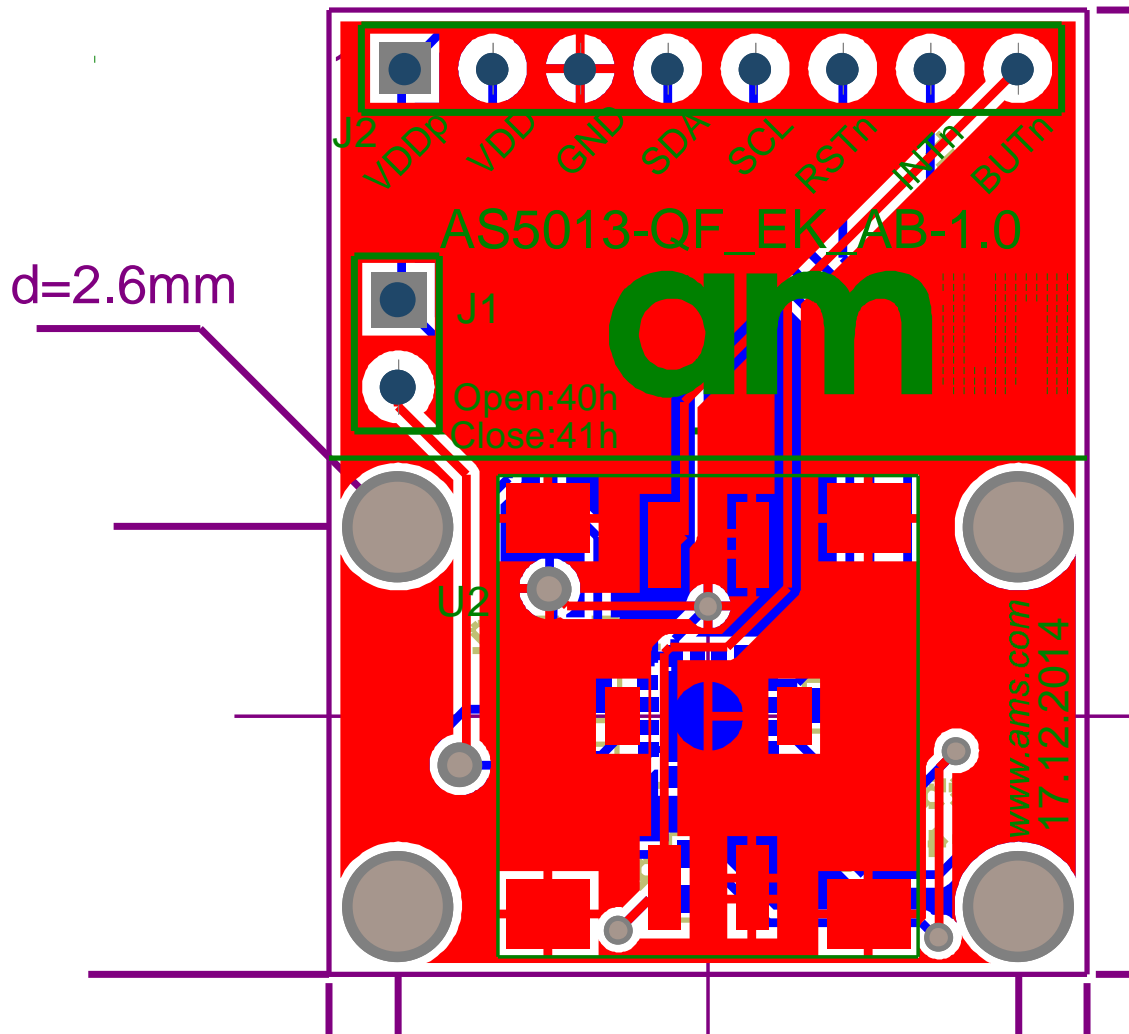

5 Ordering & Contact Information

Ordering Code	Description
AS5013-QF_EK_AB	AS5013 Eval Kit Adapter Board

Buy our products or get free samples online at:

www.ams.com/ICdirect

Technical Support is available at:

www.ams.com/Technical-Support

Provide feedback about this document at:

www.ams.com/Document-Feedback

For further information and requests, e-mail us at:

ams_sales@ams.com

For sales offices, distributors and representatives, please visit:

www.ams.com/contact

Headquarters

ams AG

Tobelbaderstrasse 30

8141 Unterpemstaetten

Austria, Europe

Tel: +43 (0) 3136 500 0

Website: www.ams.com