



**Eval Kit Manual**

# **AS5047D**

**Adapter Board**

**AS5047D-EK-AB**

## Table of Contents

1	Introduction .....	3
1.1	Kit Content .....	3
2	Board description .....	4
2.1	Mounting the AS5047D adapter board .....	5
3	AS5047D adapter board and pinout .....	6
4	Operation case .....	7
4.1	One device SPI mode, unidirectional – 3 wire .....	7
4.2	One device SPI mode, bidirectional – 4 wire .....	8
5	AS5047D-EK-AB Hardware .....	9
5.1	AS5047D-EK-AB schematics.....	9
5.2	AS5047D-EK-AB PCB layout.....	10
6	Ordering & Contact Information .....	11
7	Copyrights & Disclaimer.....	12

## Revision History

Revision	Date	Owner	Description
0.9	28.08.2013	mzie	Initial version
1.0	04.08.2014	mzie	Updates and corrections

## 1 Introduction

The AS5047D adapter board is a small PCB allowing simple and quick testing or evaluation of the AS5047D magnetic position sensor without the need to build a test fixture or design an own PCB.

### 1.1 Kit Content

Figure 1: Kit content

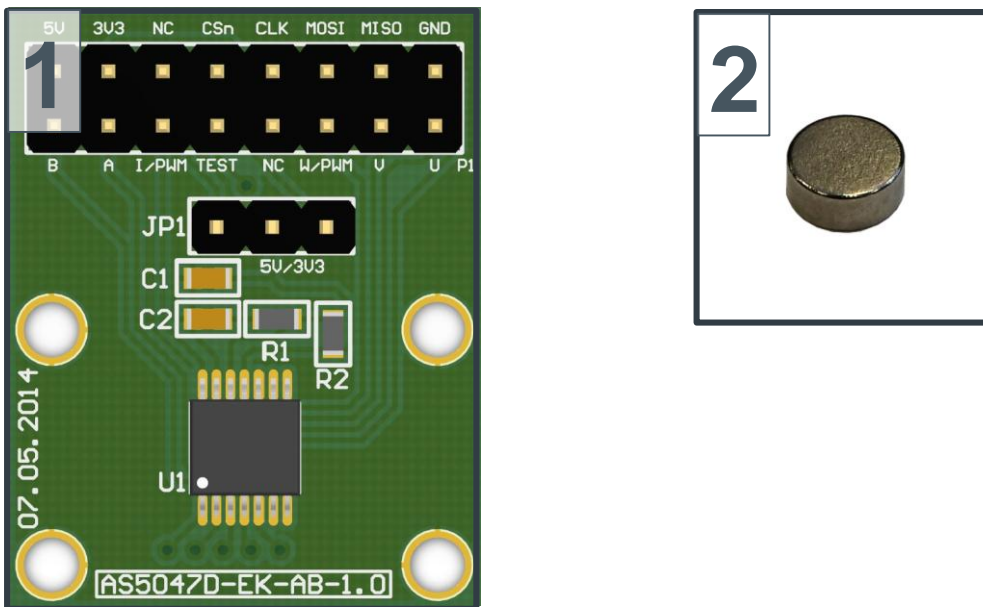

Pos.	Item	Comment
1	AS5047D-EK-AB	Adapter board
2	AS5000-MD6H-2	Diametric Magnet, D6x2.5mm, NdFeB, Bomatec AG

## 2 Board description

The PCB can either be connected to an external microcontroller or to the Universal Connector Board (AS5xxx-UCB) in combination with a NI USB-8451 box and our provided LabVIEW software.

P1 has to be populated with a 2x8 pin header and is required for power supply as well as SPI, ABI, UVW/PWM interfaces.

The connector JP1 allows to select between 5V or 3.3V operation.

Depending on the supply voltage either R1 or R2 has to be populated. For 5V operation R1 and for 3.3V operation R2 has to be populated.

**Figure 2: AS5047D adapter board**

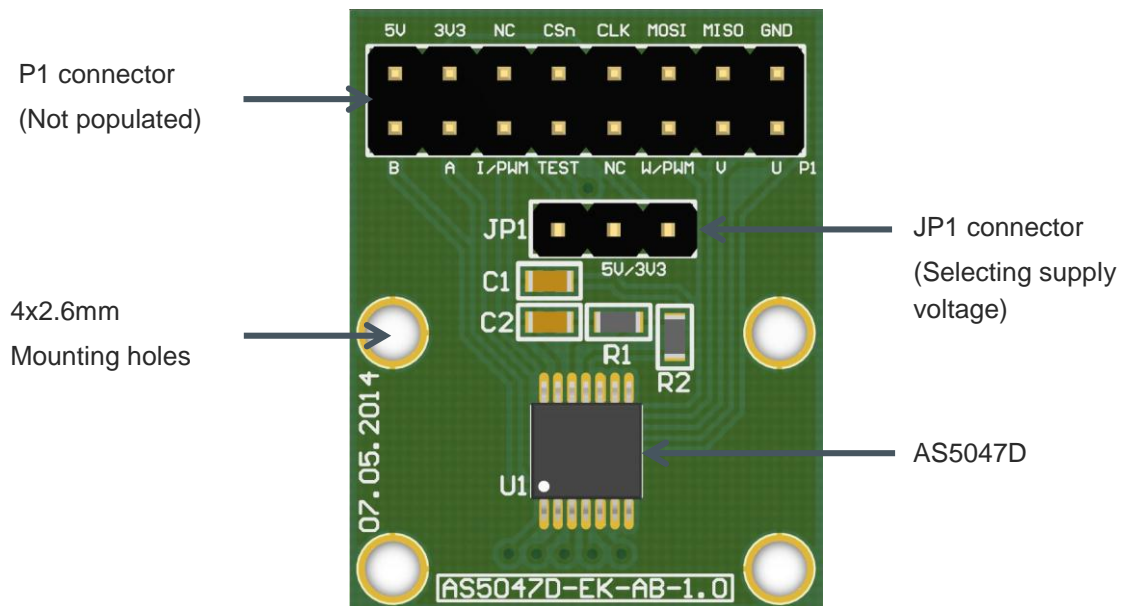

## 2.1 Mounting the AS5047D adapter board

Figure 3: Mounting and dimensions

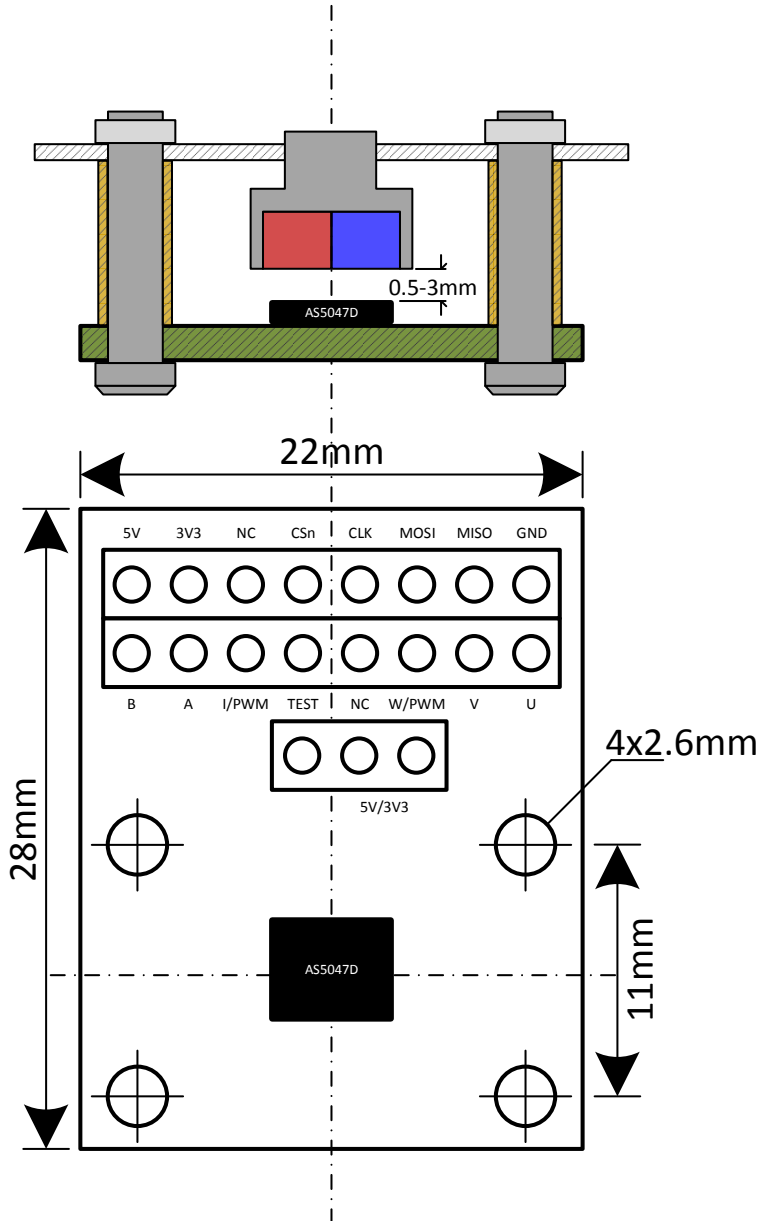

A 6x2.5mm diametric magnet must be placed over or under the AS5047D sensor, and should be centered on the middle of the package with a tolerance of 0.5mm. The airgap between the magnet surface and the package should be maintained in the range 0.5mm to 3mm. The magnet holder must not be ferromagnetic. Materials as brass, copper, aluminum, stainless steel are the best choices to make this part.

### 3 AS5047D adapter board and pinout

Figure 4: AS5047D adapter board and sensor pinout

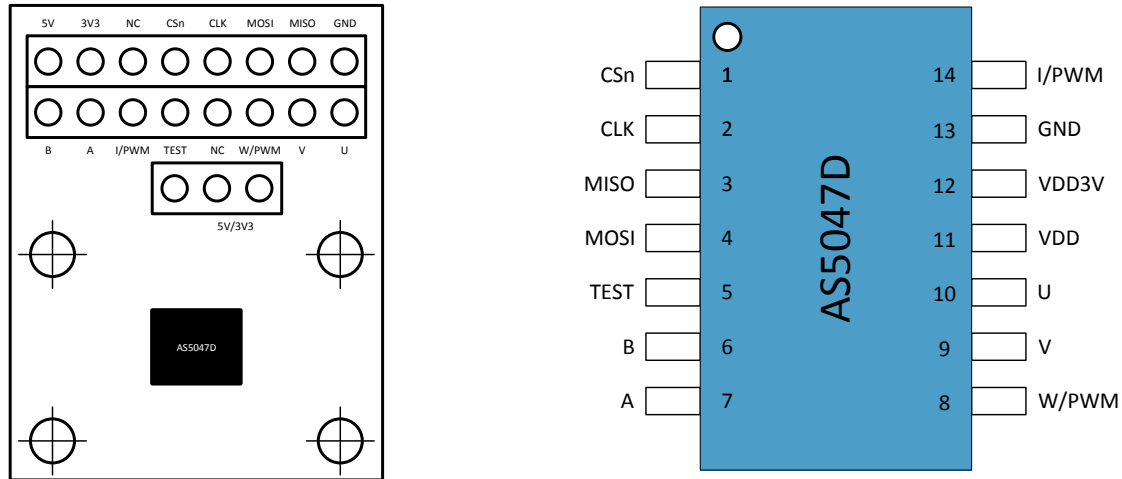

Pin# Board	Pin# AS5047D	Symbol board	Type	Description
P1 - 1	11	5V	Power supply	Positive supply voltage
P1 - 2	12	3V3	Power supply	3.3V LDO output
P1 - 3		NC		Not connected
P1 - 4	1	CSn	Digital input	SPI chip select (active low)
P1 - 5	2	CLK	Digital input	SPI Clock
P1 - 6	4	MOSI	Digital input	SPI MOSI
P1 - 7	3	MISO	Digital output	SPI MISO
P1 - 8	13	GND	Power supply	Ground
P1 - 9	6	B	Digital output	Incremental signal B (quadrature)
P1 - 10	7	A	Digital output	Incremental signal A (quadrature)
P1 - 11	14	I/PWM	Digital output	Incremental signal I (index) or PWM
P1 - 12	5	TEST		Test pin
P1 - 13		NC		Not connected
P1 - 14	8	W/PWM	Digital output	Commutation signal W or PWM
P1 - 15	9	V	Digital output	Commutation signal V
P1 - 16	10	U	Digital output	Commutation signal U

## 4 Operation case

### 4.1 One device SPI mode, unidirectional – 3 wire

The AS5047D adapter board can be directly connected to an industry standard SPI port of a microcontroller. The minimum connection requirements for unidirectional communication between the microcontroller and the AS5047D are MISO, CLK, CSn. In this case the MOSI pin is tied to VDD which will result in reading only the 14-bit Angle Register (0x3FFF). See AS5047D datasheet register table, register 0x3FFF.

Figure 5: One device SPI mode, unidirectional – 3 wire

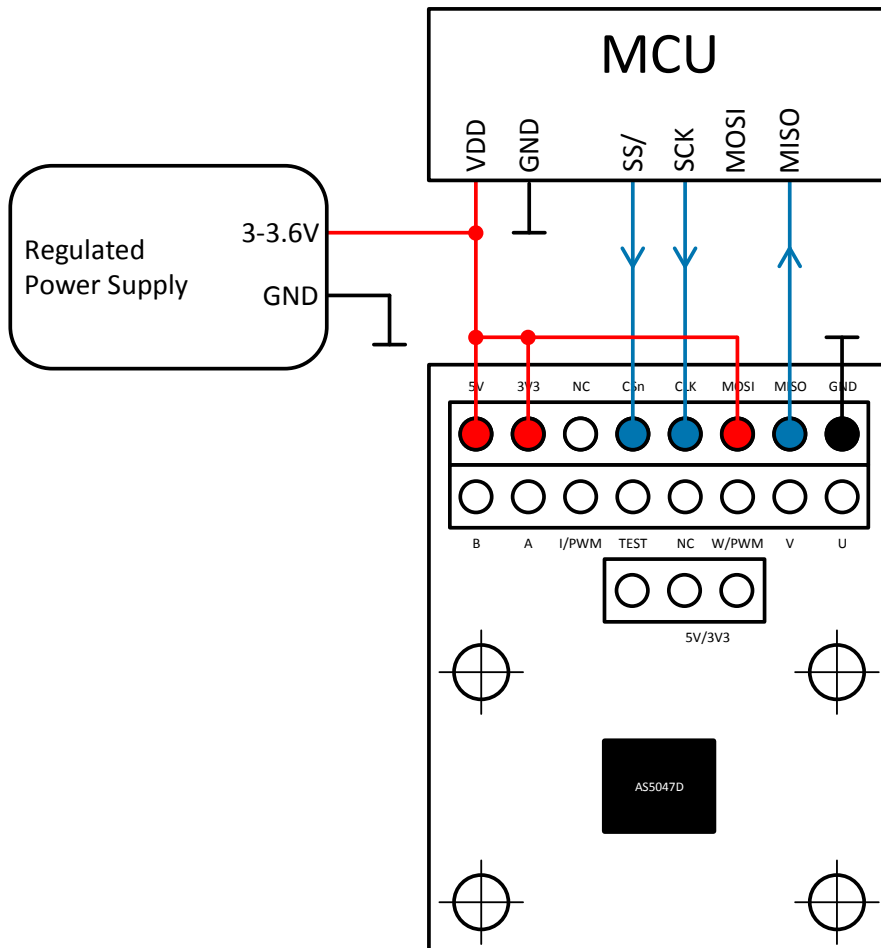

## 4.2 One device SPI mode, bidirectional – 4 wire

If it's needed to read other registers than the Angle Register (0x3FFF) or to write to registers of the AS5047D the MOSI connection is required.

Figure 6: One device SPI mode, bidirectional – 4 wire

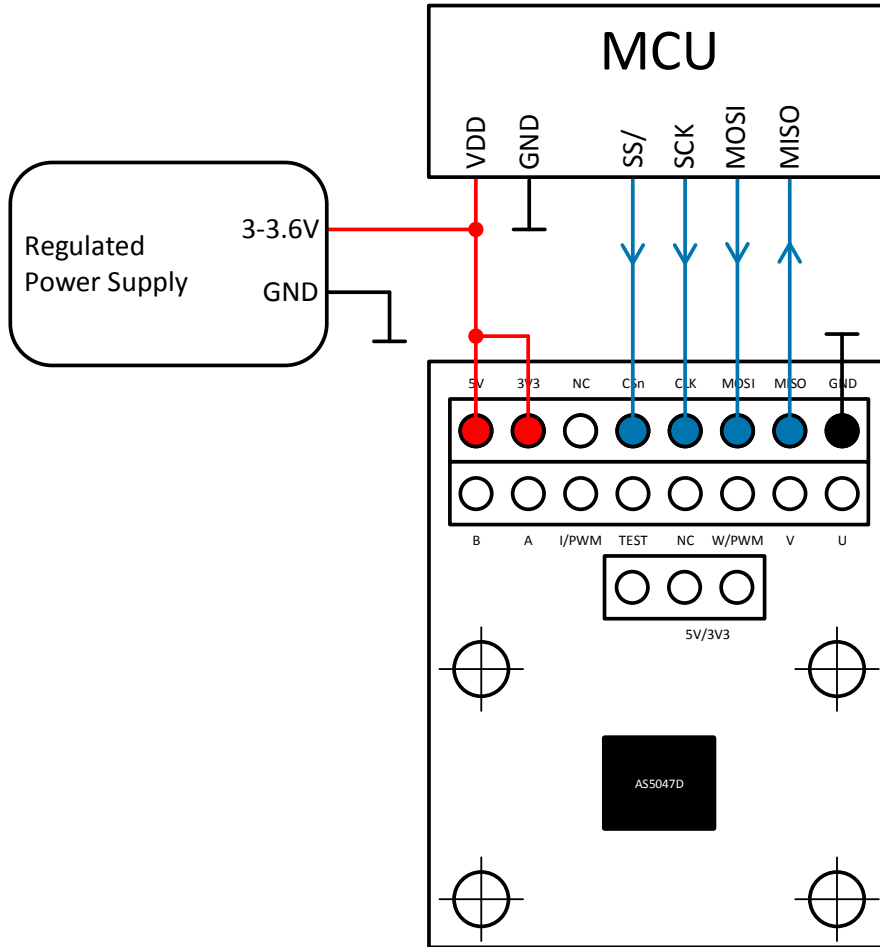



## 5 AS5047D-EK-AB Hardware

### 5.1 AS5047D-EK-AB schematics

Figure 7: AS5047D-EK-AB schematics

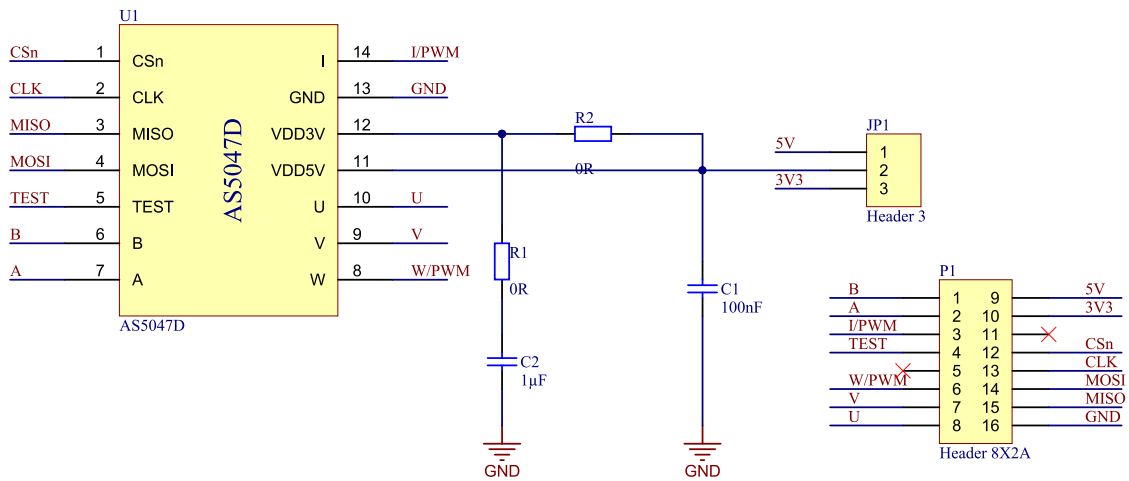

## 5.2 AS5047D-EK-AB PCB layout

Figure 8: AS5047D-EK-AB PCB layout

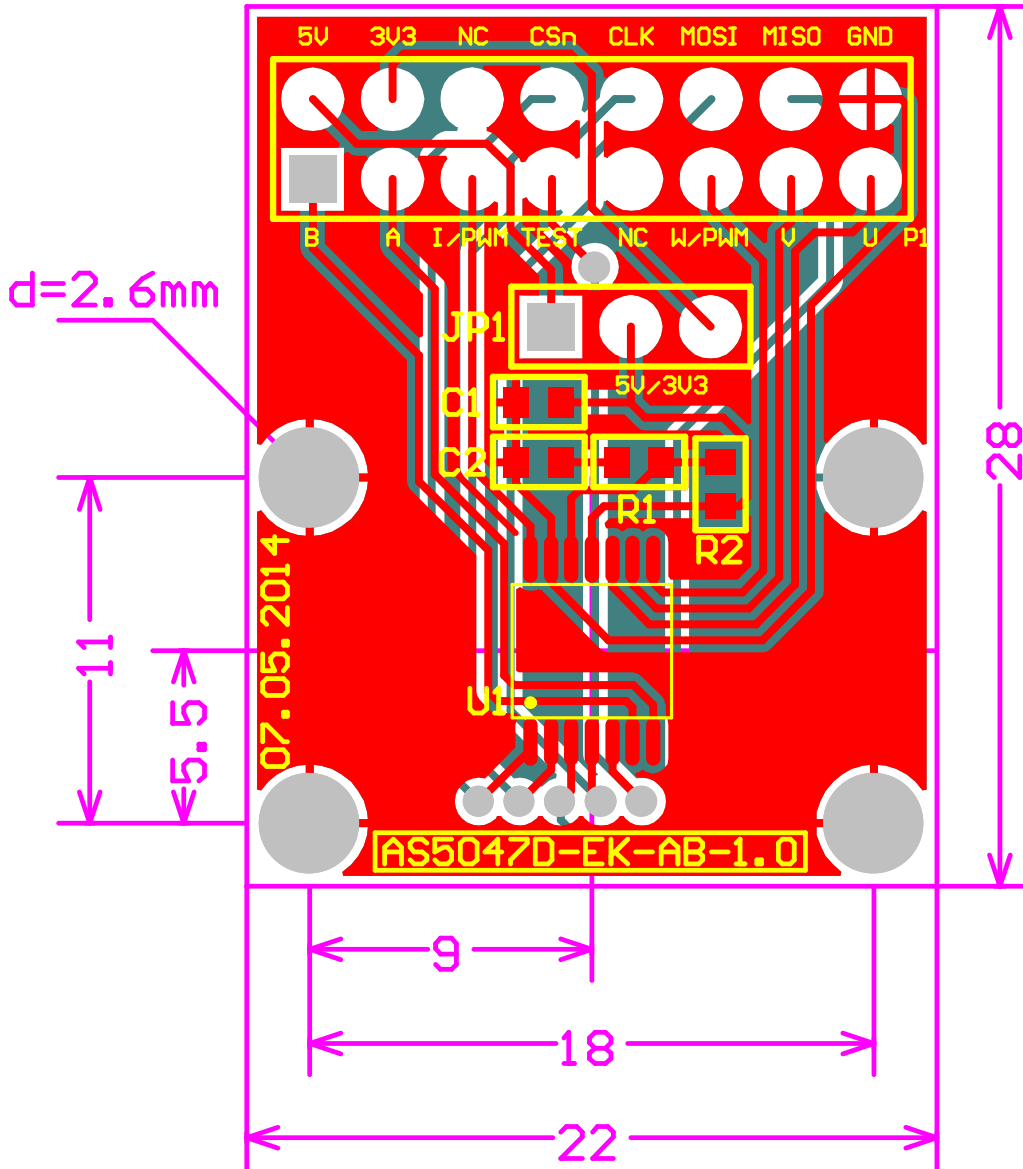

## 6 Ordering & Contact Information

Ordering Code	Description
AS5047D-EK-AB	AS5047D Eval Kit Adapter Board

**Buy our products or get free samples online at:**

[www.ams.com/ICdirect](http://www.ams.com/ICdirect)

**Technical Support is available at:**

[www.ams.com/Technical-Support](http://www.ams.com/Technical-Support)

**Provide feedback about this document at:**

[www.ams.com/Document-Feedback](http://www.ams.com/Document-Feedback)

**For further information and requests, e-mail us at:**

[ams\\_sales@ams.com](mailto:ams_sales@ams.com)

**For sales offices, distributors and representatives, please visit:**

[www.ams.com/contact](http://www.ams.com/contact)

### Headquarters

ams AG

Tobelbaderstrasse 30

8141 Unterpemstaetten

Austria, Europe

Tel: +43 (0) 3136 500 0

Website: [www.ams.com](http://www.ams.com)