



austriamicrosystems AG

is now

ams AG

The technical content of this austriamicrosystems document is still valid.

Contact information:

Headquarters:

ams AG

Tobelbader Strasse 30

8141 Premstaetten, Austria

Tel: +43 (0) 3136 500 0

e-Mail: ams_sales@ams.com

Please visit our website at www.ams.com

1 AS5048 Demoboard

The AS5048 Demoboard is a complete rotary encoder system with built-in microcontroller, USB interface and graphical LCD display.

The board is USB powered or externally supplied with a 9V battery for standalone operation.

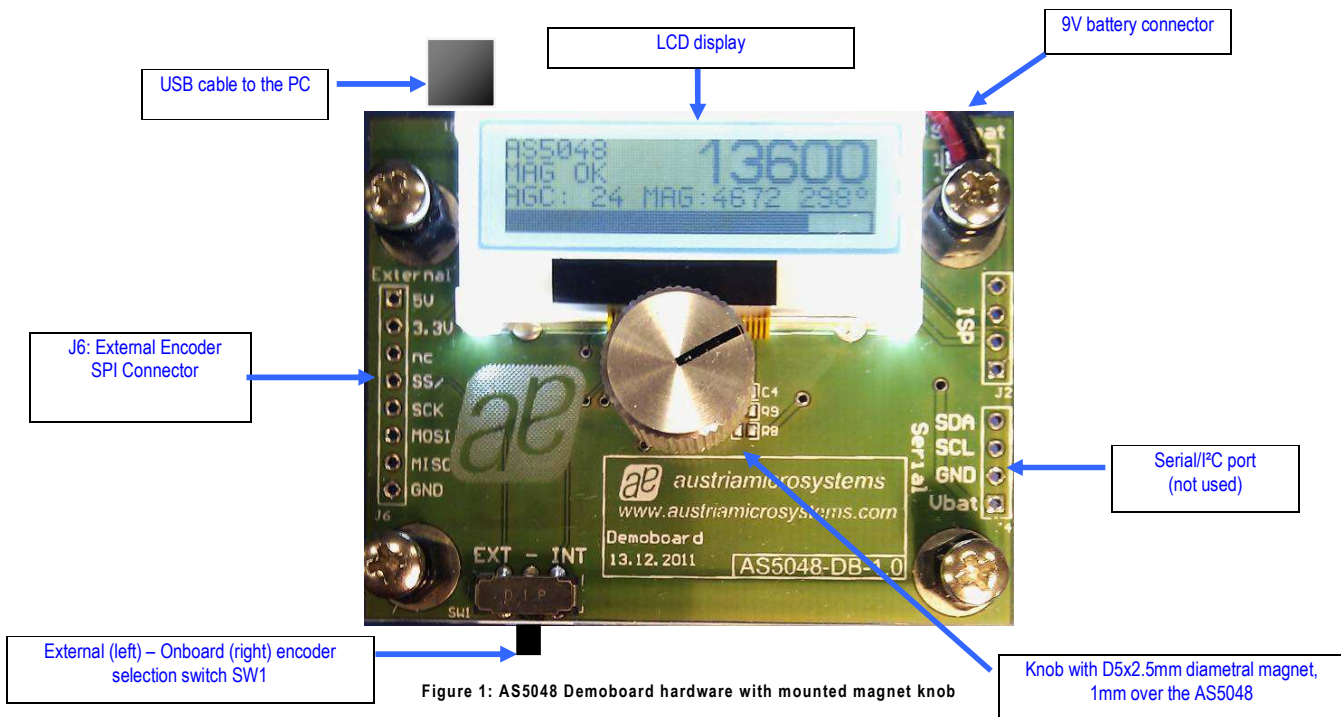

2 Operating the AS5048 Demoboard

The AS5048 Demoboard can be used in several ways:

- **As standalone unit supplied by a 9V battery**

Connect a 9V battery to the battery connector on the top right side of the board. No other connections are required.

- **As standalone unit supplied by an USB port**

Connect the Demoboard to a PC using a USB cable (included in Demoboard shipment). The board is supplied by the 5V supply of the USB port. No other connections are required.

After installation of the AS5xxx Evaluation software (available on our AMS website) .



Figure 2 Graphical user interface

Hardware Indicators and Connectors

2.1.1 Graphic LCD display

The LCD display shows the realtime absolute angle position of the magnet and the absolute value of the angle. Turning the knob clockwise will increase the angle value until 359° then 0°.

The magnet status indicator is related to the magnet position. If the magnet is too close to the encoder, "TOO CLOSE" will be displayed. If the magnet is too far away from the encoder, "TOO FAR" will be displayed.

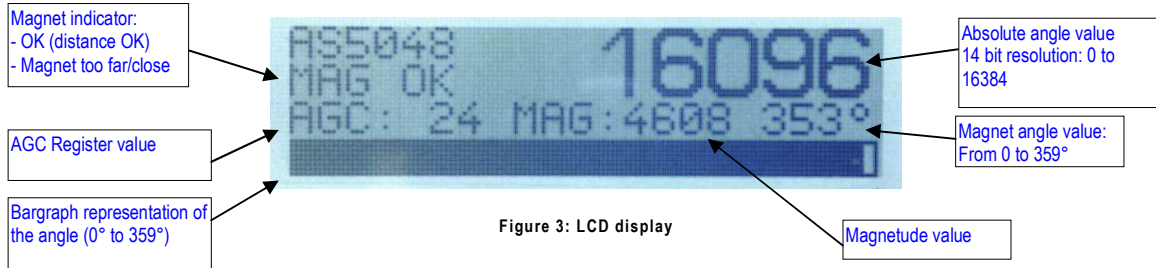

Figure 3: LCD display

2.1.2 Encoder selection switch

The switch SW1 selects the encoder which communicates with the microcontroller through the SSI bus:

1. Right position (default): Onboard AS5048
2. Left Position: External AS5048 connected on J6
 The signals of the synchronous serial interface (MOSI, MISO, SCK, SS/) and the power supply (3.3V, GND) of an external device can be connected directly to J6. In this configuration, the data of the serial interface are displayed on the LCD.

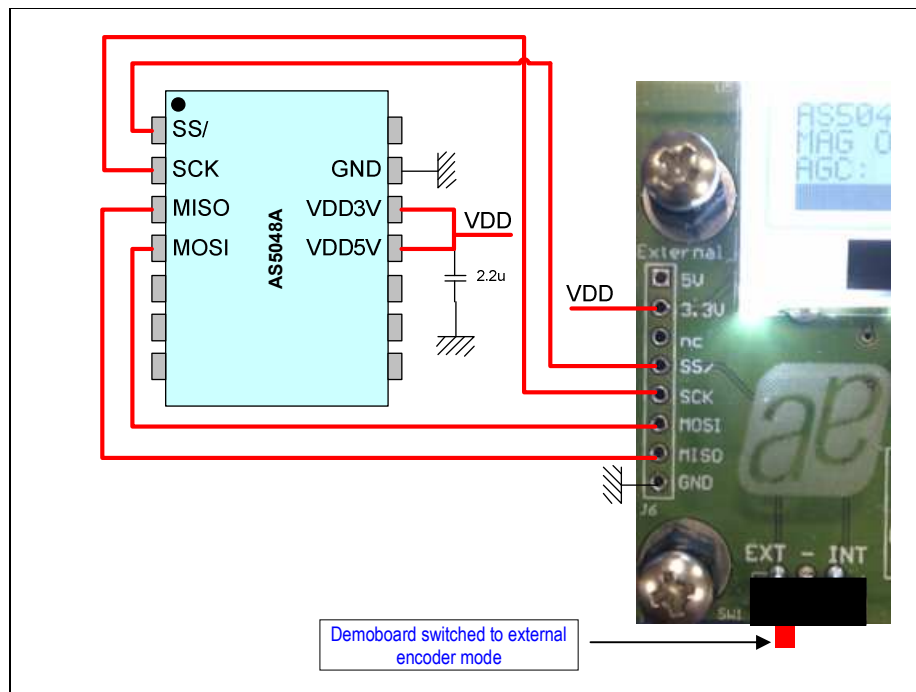

Figure 4: external AS5048 connection to the demoboard

3 AS5048 Demoboard, Schematics, block diagram

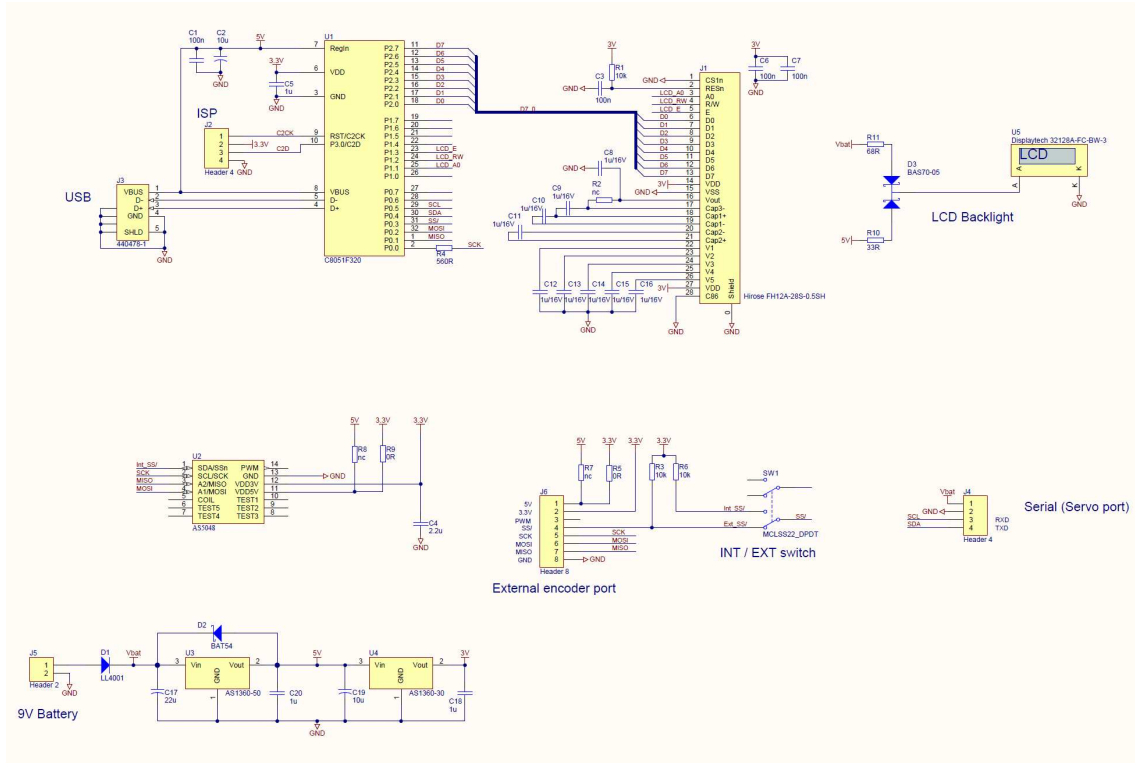

Figure 5: AS5048 Demoboard schematics

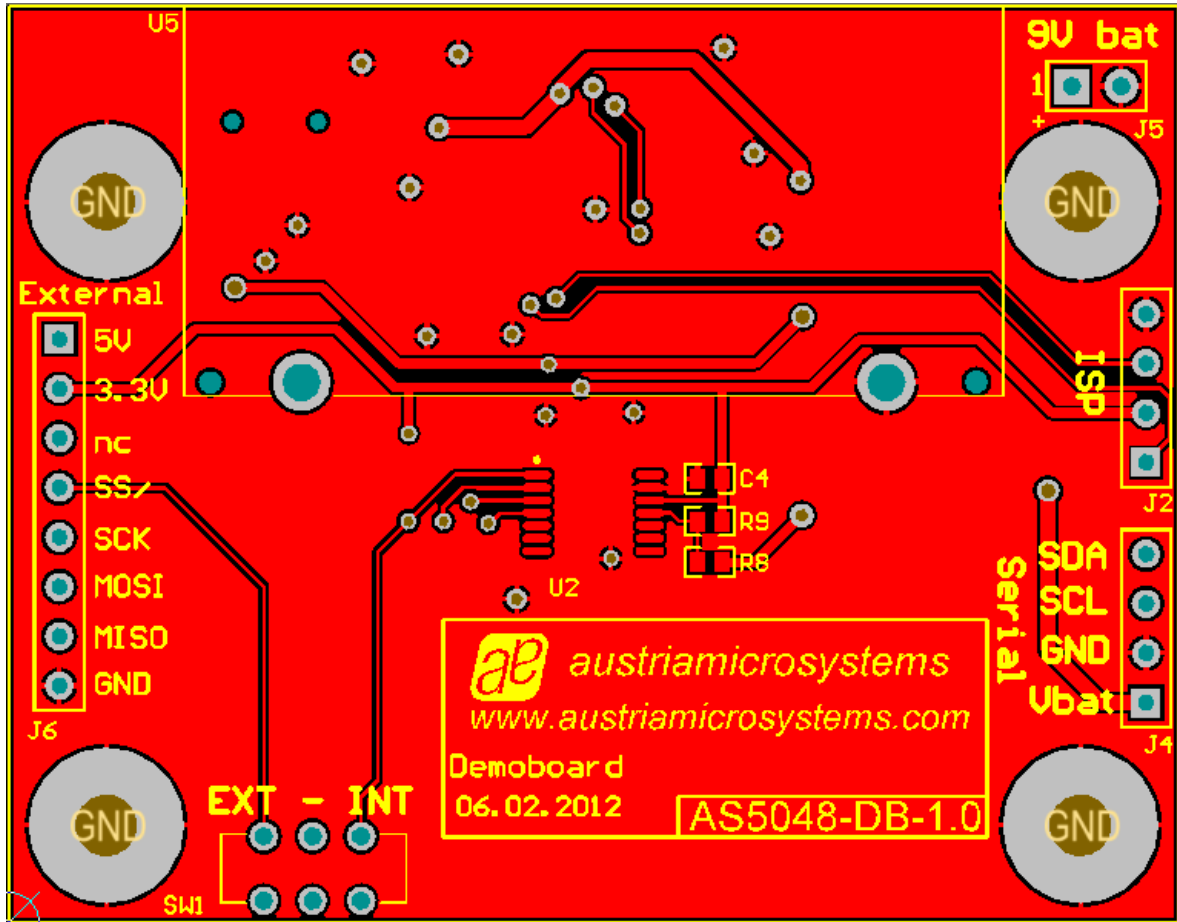

Figure 6: AS5048 Demoboard PCB Layout

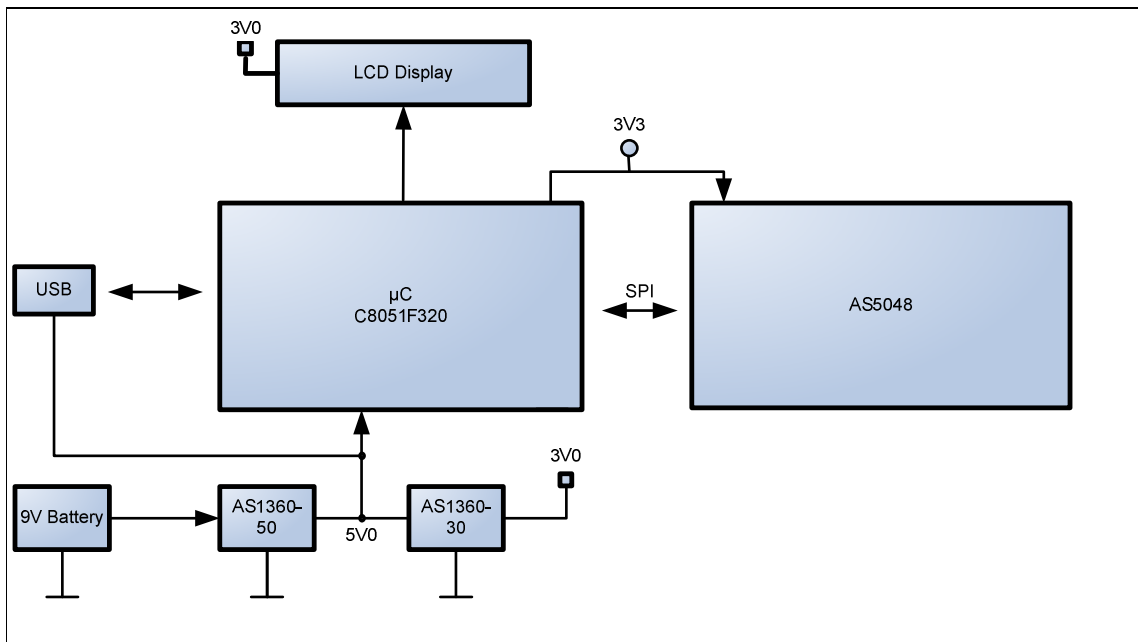

Figure 7: AS5048 block diagram

Index

1	AS5048 Demoboard	1
2	Operating the AS5048 Demoboard	2
2.1.1	Graphic LCD display	3
2.1.2	Encoder selection switch	3
3	AS5048 Demoboard, Schematics, block diagram	4
	Index	6
	Revision History	7
	Contact	8
	Copyright	9

Revision History

Revision	Date	Description	
R1.0	January 9, 2012	First version	

Contact

Headquarters

austriamicrosystems AG
 A 8141 Schloss Premstätten, **Austria**
 Phone: +43 3136 500 0
 Fax: +43 3136 525 01
industry.medical@austriamicrosystems.com
www.austriamicrosystems.com

Sales Offices

austriamicrosystems Germany GmbH
 Tegemseer Landstrasse 85
 D-81539 München, **Germany**
 Phone: +49 89 69 36 43 0
 Fax: +49 89 69 36 43 66

austriamicrosystems Italy S.r.l.
 Via A. Volta, 18
 I-20094 Corsico (MI), **Italy**
 Phone: +39 02 4586 4364
 Fax: +39 02 4585 773

austriamicrosystems France S.A.R.L.
 124, Avenue de Paris
 F-94300 Vincennes, **France**
 Phone: +33 1 43 74 00 90
 Fax: +33 1 43 74 20 98

austriamicrosystems Switzerland AG
 Rietstrasse 4
 CH 8640 Rapperswil, **Switzerland**
 Phone: +41 55 220 9008
 Fax: +41 55 220 9001

austriamicrosystems UK, Ltd.
 88, Barkham Ride,
 Finchampstead, Wokingham
 Berkshire RG40 4ET, **United Kingdom**
 Phone: +44 118 973 1797
 Fax: +44 118 973 5117

austriamicrosystems AG
 Klaavuntie 9 G 55
 FI 00910 Helsinki, **Finland**
 Phone: +358 9 72688 170
 Fax: +358 9 72688 171

austriamicrosystems AG
 Bivågen 3B
 S 19163 Sollentuna, **Sweden**
 Phone: +46 8 6231 710

austriamicrosystems USA, Inc.
 8601 Six Forks Road
 Suite 400
 Raleigh, NC 27615, **USA**
 Phone: +1 919 676 5292
 Fax: +1 509 696 2713

austriamicrosystems USA, Inc.
 4030 Moorpark Ave
 Suite 116
 San Jose, CA 95117, **USA**
 Phone: +1 408 345 1790
 Fax: +1 509 696 2713

austriamicrosystems AG
 Suite 811, Tsimshatsui Centre
 East Wing, 66 Mody Road
 Tsim Sha Tsui East, Kowloon, **Hong Kong**
 Phone: +852 2268 6899
 Fax: +852 2268 6799

austriamicrosystems AG
 AIOS Gotanda Annex 5th Fl., 1-7-11,
 Higashi-Gotanda, Shinagawa-ku
 Tokyo 141-0022, **Japan**
 Phone: +81 3 5792 4975
 Fax: +81 3 5792 4976

austriamicrosystems AG
 #805, Dong Kyung Bldg.,
 824-19, Yeok Sam Dong,
 Kang Nam Gu, Seoul
Korea 135-080
 Phone: +82 2 557 8776
 Fax: +82 2 569 9823

austriamicrosystems AG
 Singapore Representative Office
 83 Clemenceau Avenue, #02-01 UE Square
 239920, **Singapore**
 Phone: +65 68 30 83 05
 Fax: +65 62 34 31 20