



User Guide

UG000455

AS5116 Adapter Board

Adapter Board User Manual

AS5116-SO_EK_AB

v1-00 • 2019-Oct-22

Content Guide

1	Introduction.....	3	5	Hardware.....	9
1.1	Kit Content.....	3	5.1	Schematics.....	9
1.2	Ordering Information	3	5.2	Layout	10
2	Board Description.....	4	6	Revision Information.....	11
2.1	Mounting the AS5116 Adapter Board	5	7	Legal Information	12
3	Adapter Board and Pinout	6			
4	Operation Case	7			
4.1	Programming with ams I&P Box (https://ams.com/usbi-pbox).....	8			

1 Introduction

The AS5116 Adapter Board is a small PCB allowing simple and quick testing or evaluation of the AS5116 magnetic position sensor without the need to build a test fixture or design an own PCB.

AS5116-SO_EK_AB is assembled with an AS5116 sensor.

1.1 Kit Content

Figure 1:
Adapter Board

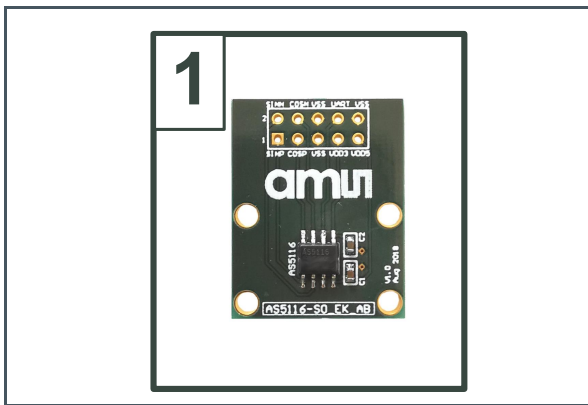

Figure 2:
Diametric Magnet



Pos.	Item	Comment
1	AS5116-SO_EK_AB	Adapter board
2	AS5000-MD8H-2	Diametric magnet, D8x2.5 mm, NdFeB, Bomatec AG

1.2 Ordering Information

Ordering Code	Description
AS5116-SO_EK_AB	Adapter board assembled with AS5116 per default

2 Board Description

The PCB can be connected either to an external microcontroller or to the USB I&P Box, which is available on our webpage (USB I&P Box).

The connector, 2x5 pin header (not populated), is included to this kit and is required for power supply as well as UART and analog interface.

C1 (100 nF) and C2 (1 μ F) are capacitors to stabilize supply voltage.

Figure 3:
AS5116 Adapter Board

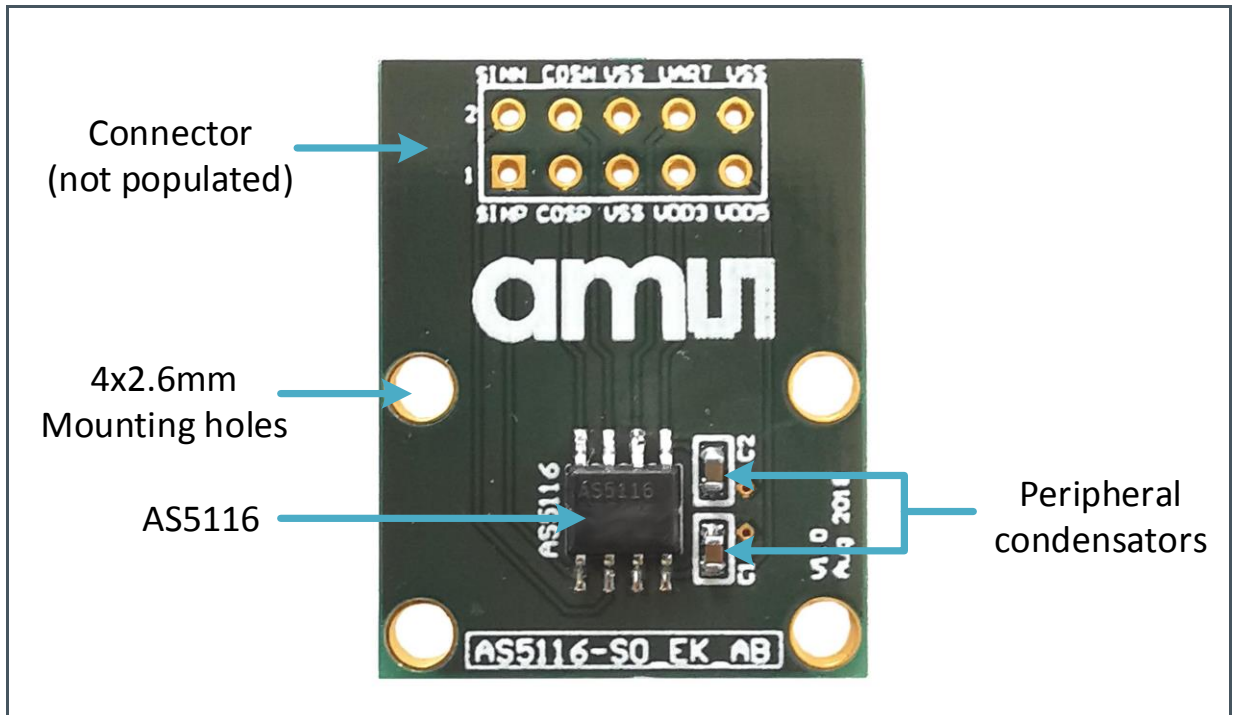

2.1 Mounting the AS5116 Adapter Board

Figure 4:
Mounting and Dimensions

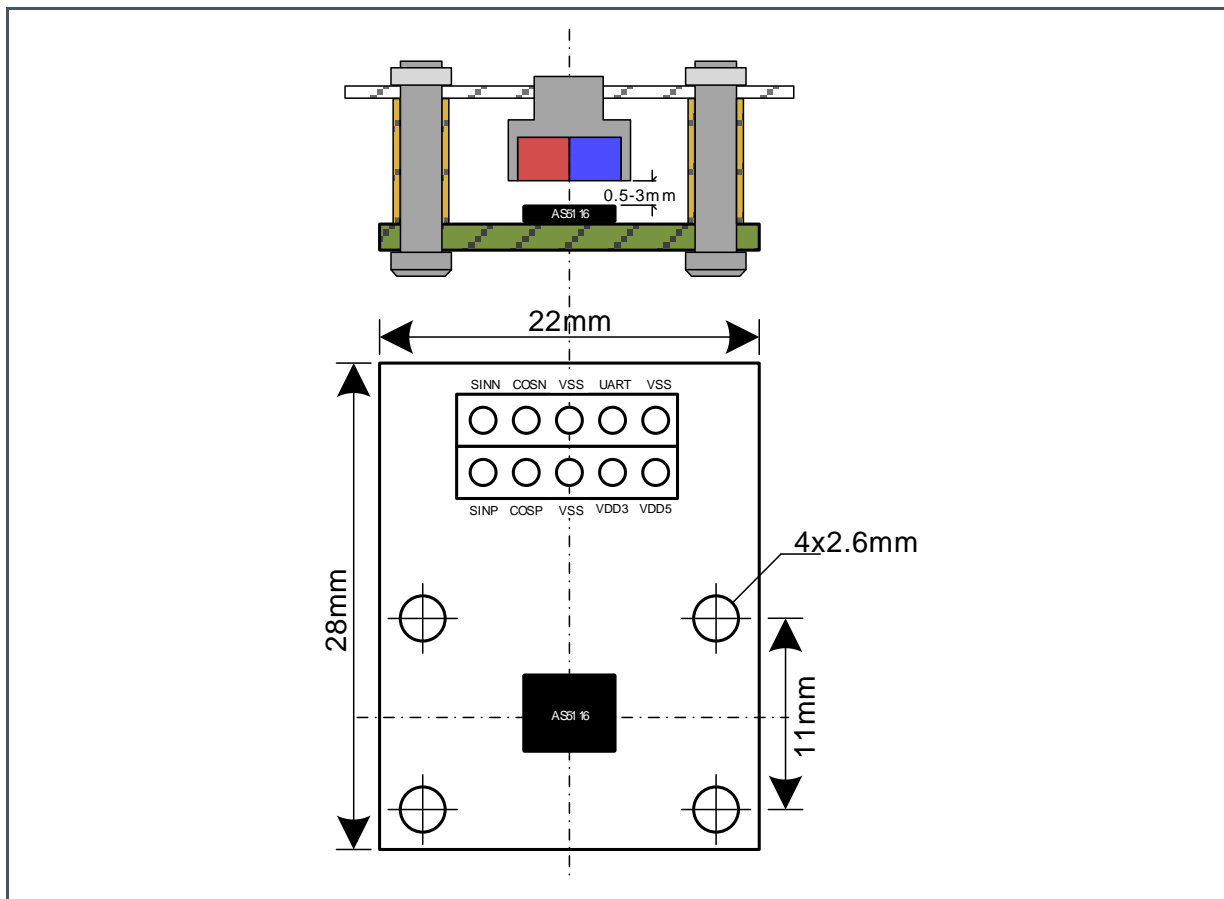

A diametric magnetized magnet must be placed over or under the AS5116 sensor, and should be centered on the middle of the package with a tolerance of 0.5 mm. The air gap between the magnet surface and the package should be maintained in the range 0.5 mm to 3 mm. The magnet holder must not be ferromagnetic. Materials like brass, copper, aluminum, stainless steel are the best choices to make this part.

3 Adapter Board and Pinout

Figure 5:
Adapter Board Pinout

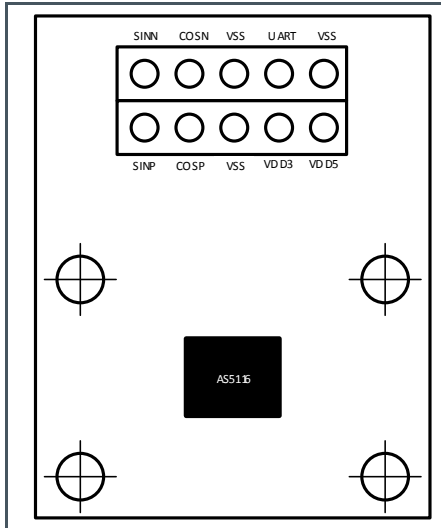

Figure 6:
Sensor Pinout

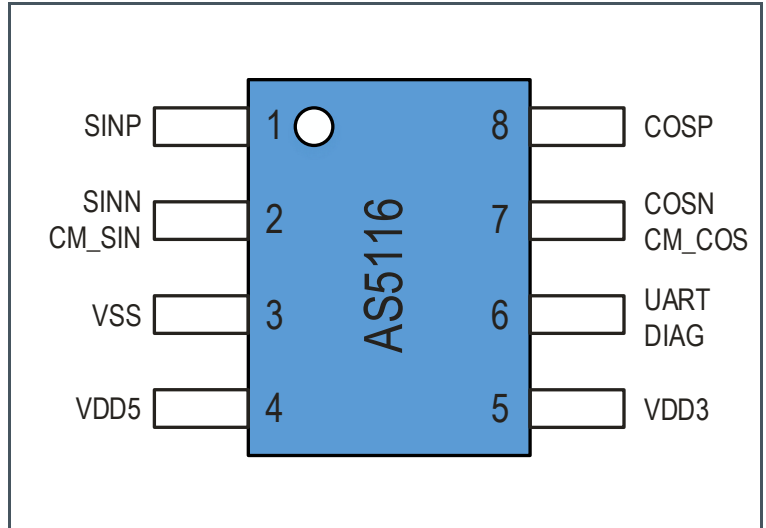

Figure 7:
Pinout Description

Pin# Board	Pin# AS5116	Symbol Board	Type	Description
P1 - 1	1	SINP	Analog output	Buffered sine channel, positive output
P1 - 2	8	COSP	Analog output	Buffered cosine channel, positive output
P1 - 3	3	VSS	Power supply	Ground
P1 - 4	5	VDD3	Power supply	3.3 V LDO output
P1 - 5	4	VDD5	Power supply	Positive supply voltage 5V
P1 - 6	3	VSS	Power supply	Ground
P1 - 7	6	UART	Digital I/O	Communication Pin for OTP programming
P1 - 8	3	VSS	Power supply	Ground
P1 - 9	7	COSN	Analog output	Buffered cosine channel, inverted output
P1 - 10	2	SINN	Analog output	Buffered sine channel, inverted output

4 Operation Case

The adapter board can be supplied with 5 V or with 3.3 V. In case of 5 V supply, the pin VDD3 is left open and VDD5 is connected to 5 V-supply voltage. In case of 3.3 V supply, the pin VDD3 and VDD5 are connected to 3.3 V-Supply voltage.

Digital I/O pins operates at 3.3 V level.

Figure 8:
3.3 V Operation

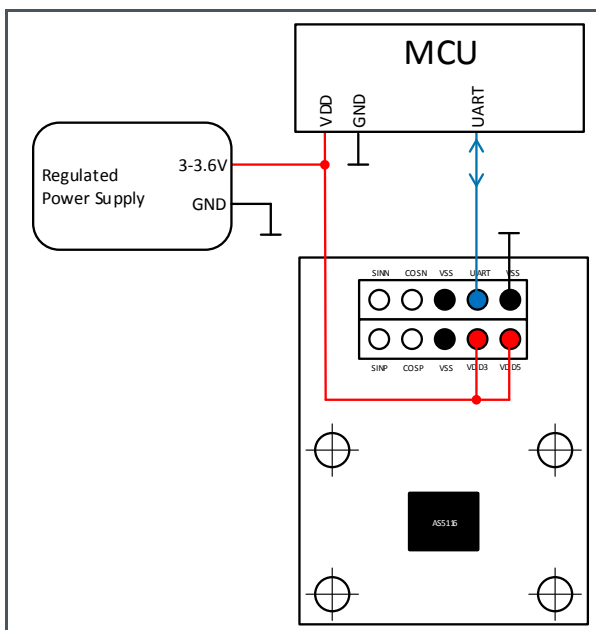
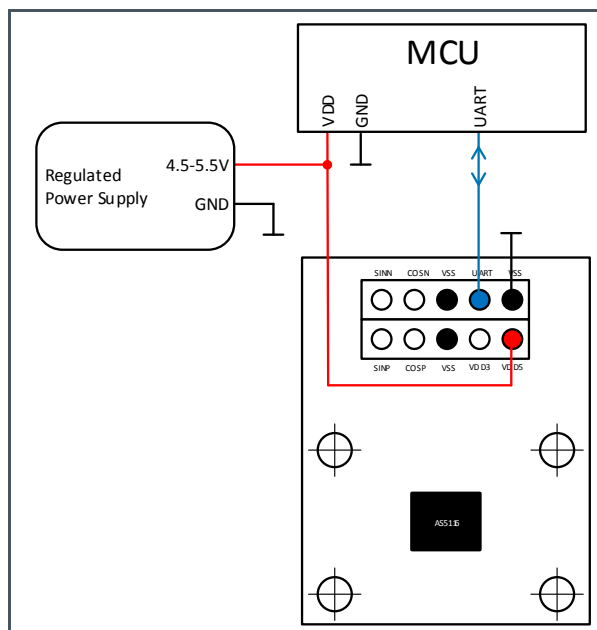

Figure 9:
5 V Operation



4.1 Programming with **ams I&P Box** (<https://ams.com/usbi-pbox>)

The Adapter Board cannot be connected directly to the I&P Box. There is a need of additional buffer, switched in between or use the Socket board (AS5116-SO_EK_SB). The Buffer-IC circuitry is on the Socket Board included

Additional recommended components are:

- Buffer-IC: 74HC1G125
- Resistor: 10 k Ohm.

Figure 10:
Programming via I&P Box

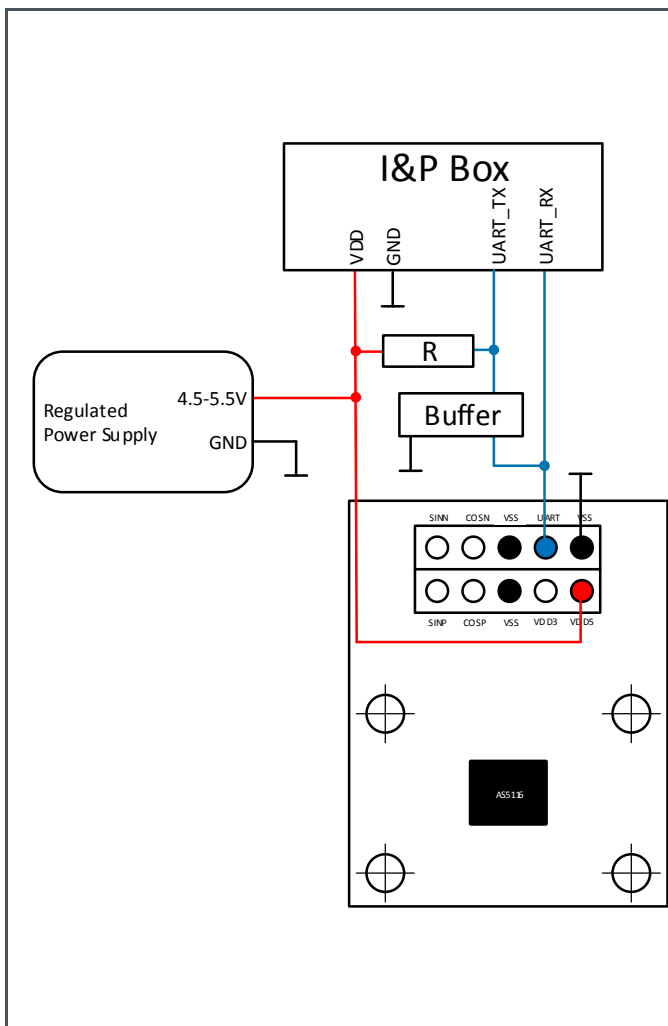
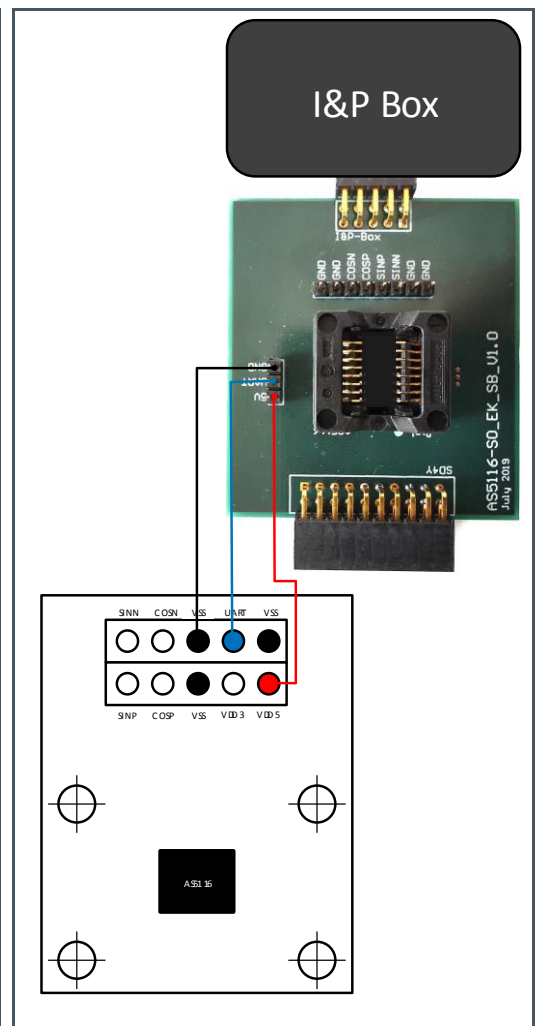

Figure 11:
Programming via I&P Box with Socket Board between



5 Hardware

5.1 Schematics

Figure 12:
Schematic

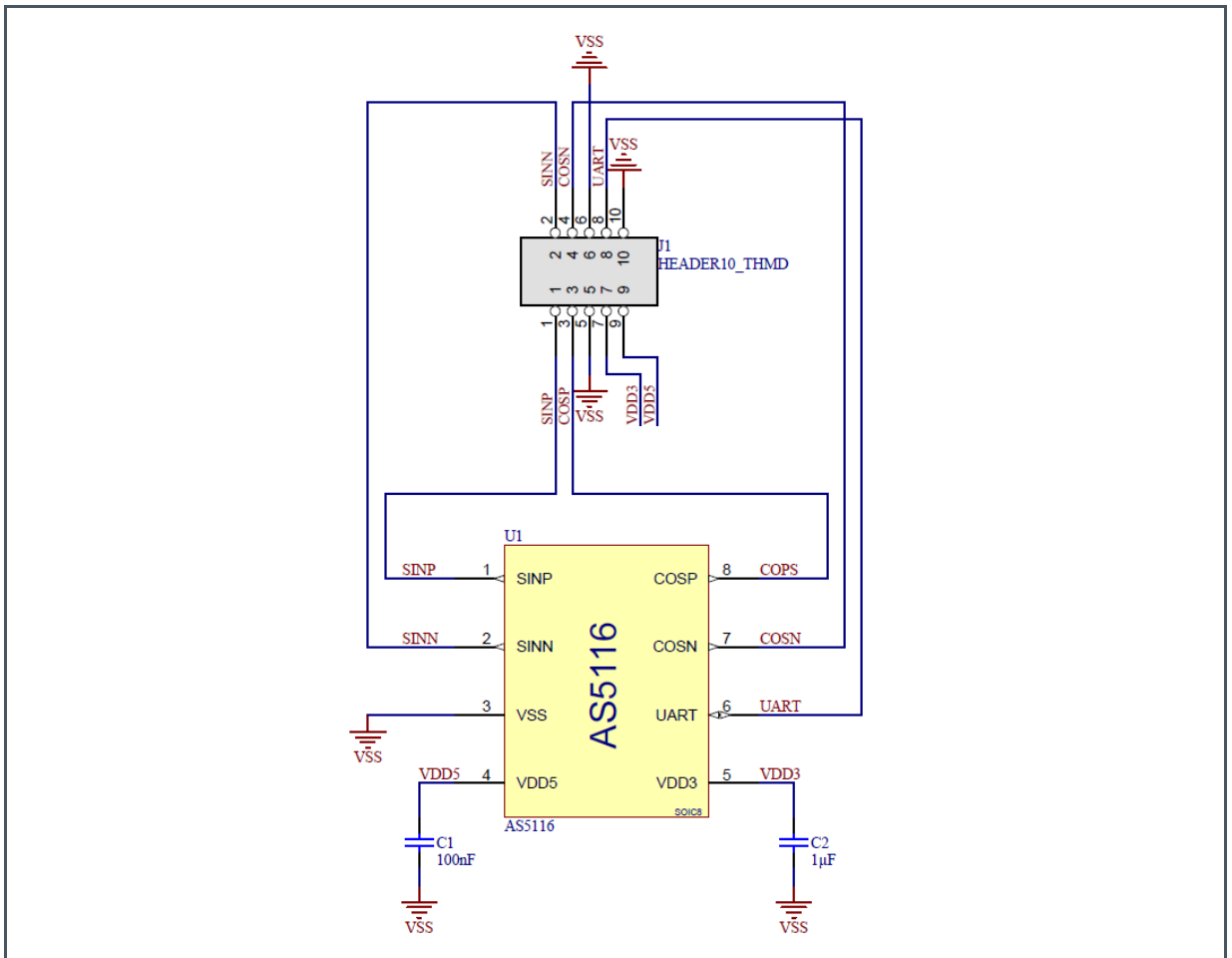

5.2 Layout

The adapter board is based on two copper layers. All signal and supply lines are placed on Top-Layer, Bottom-Layer is used as ground plane.

The four mounting holes are connected to GND as well.

Figure 13 :
PCB Layout

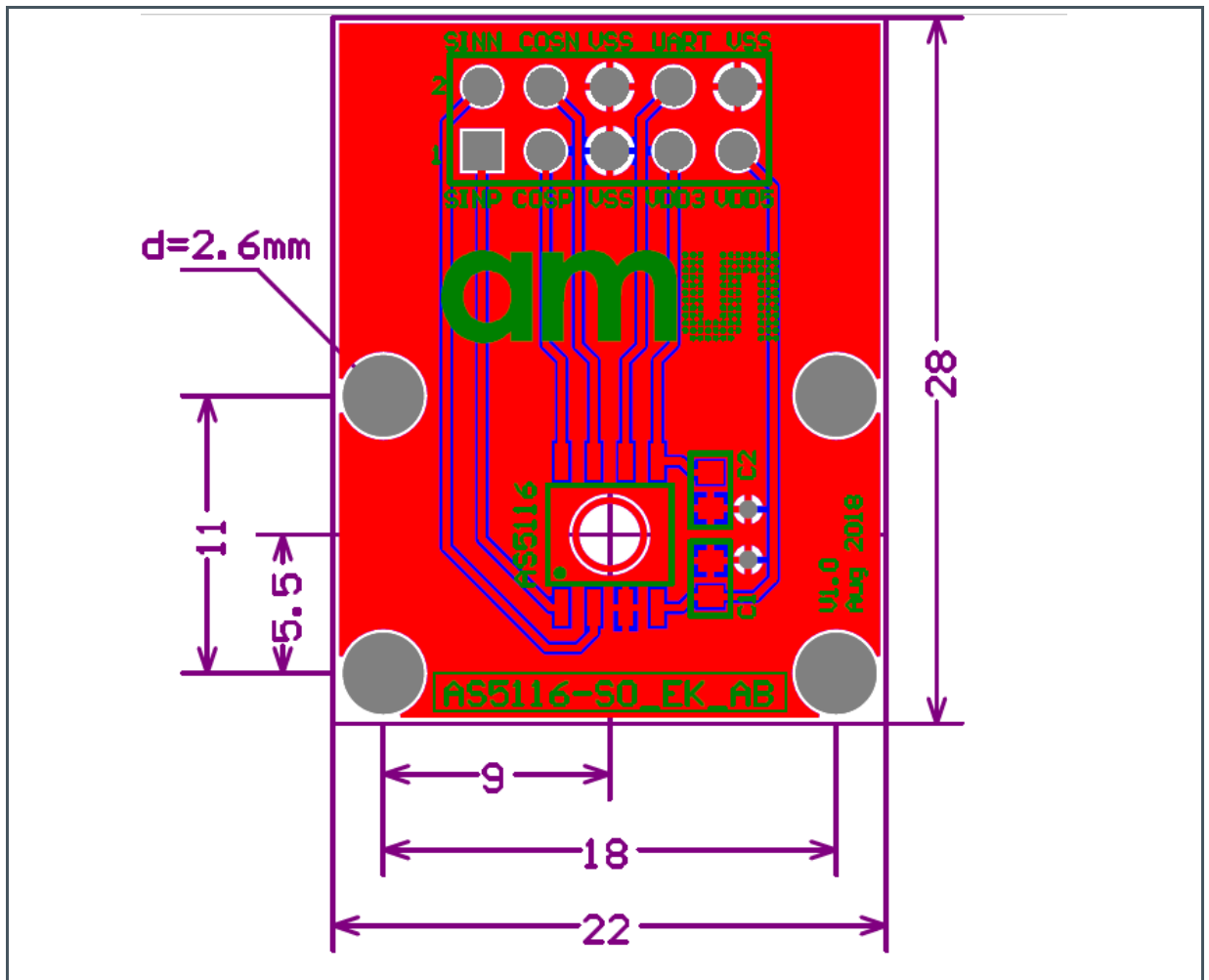

6 Revision Information

Changes from previous version to current revision v1-00	Page
---	------

Initial version

- Page and figure numbers for the previous version may differ from page and figure numbers in the current revision.
- Correction of typographical errors is not explicitly mentioned.