

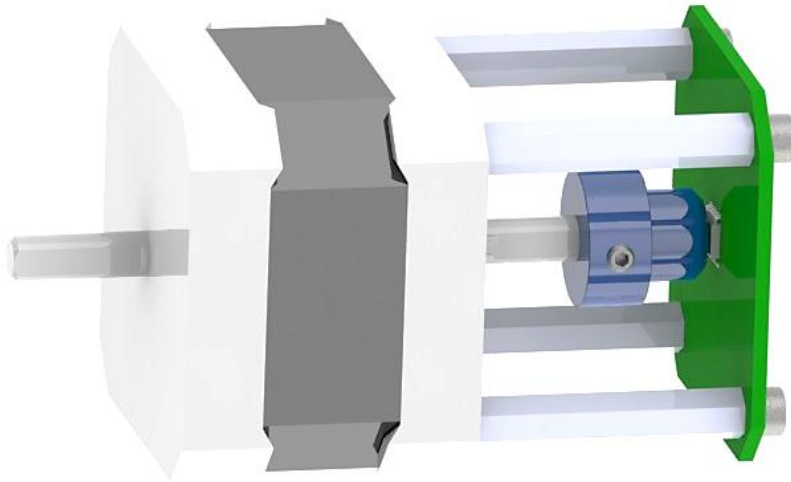

Operation Manual: AS5145B-EK-AB-STM1.0



AS5145B Eval-Kit Stepper Motor



Table of Contents

- 1. General Description 2
- 2. Package and Board Description 2
- 3. How to get the Eval-Kit running 4
- 4. Mechanical Design Considerations 5
- 5. Schematics, Layout 6
- Copyright** 9
- Disclaimer** 9
- Contact Information** 9

1. General Description

The AS5145B Eval-Kit is designed to adapt standard size stepper motors with a contactless rotary position sensor. Rotation of the magnet holders is sensed by the rotary position sensor, soldered on the PCB board.

2. Package and Board Description

Content of the Eval-Kit:

- AS5145B board

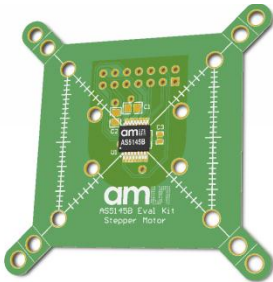

- 4 magnet holders



Ø 5mm

Ø 6mm

Ø 8mm

Ø 10mm

- 1 allen key (1.5mm)



- 1 quick start user guide

Figure 1: Connector

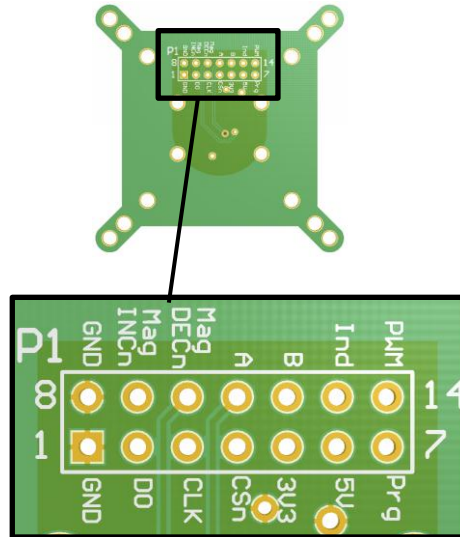
Table 1:
Connector pinout

Pin	Description	Info
1	GND	Ground
2	DO	Data Output of SSI
3	CLK	Clock Input of SSI
4	CSn	Chip Select
5	3V3	3.3V-Regulator Output.
6	5V	Positive Supply Voltage.
7	Prg	Programming Input.
8	GND	GND
9	MagINCn	magnet field status indicator
10	MagDECn	magnet field status indicator
11	A	Quadrature Output A
12	B	Quadrature Output B
13	Ind	Index Output
14	PWM	Pulse Width Modulation output

3. How to get the Eval-Kit running

Figure 2:
5V Power Option

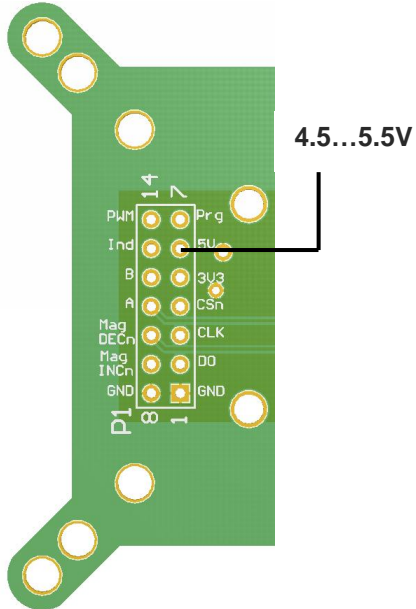
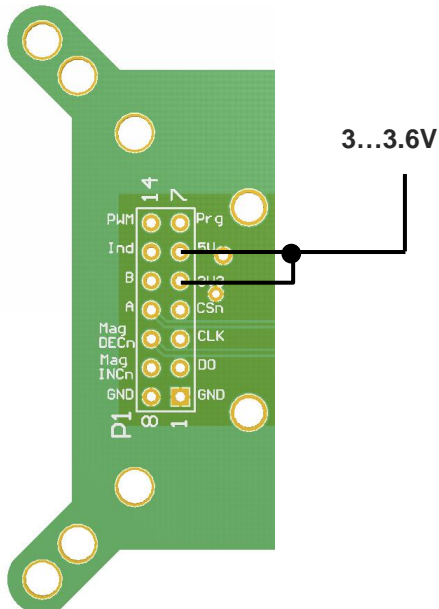

Figure 3:
3V Power Option



4. Mechanical Design Considerations

Table 2:
Motor References (Examples)

Part Number	Web Page	Manufacturer
17PY-X0XX	www.nmbtc.com	NMB Technologies Corporation - Motor Group
17PY-X8XX		
17PY-X4XX		
17H018D series	www.portescap.com	Portescap
17H118D series		
17H218D series		



Table 3:
Used Magnet

Part Number	Web Page	Manufacturer
2910041-1	www.dexterimg.com	Dexter Magnetic Technologies



Additional recommended magnet suppliers refer to our homepage:

<http://www.ams.com/eng/Products/Magnetic-Encoders/Magnets2/Recommended-Magnet-Suppliers>

Figure 4:
Mounting the AS5145B Eval-Kit

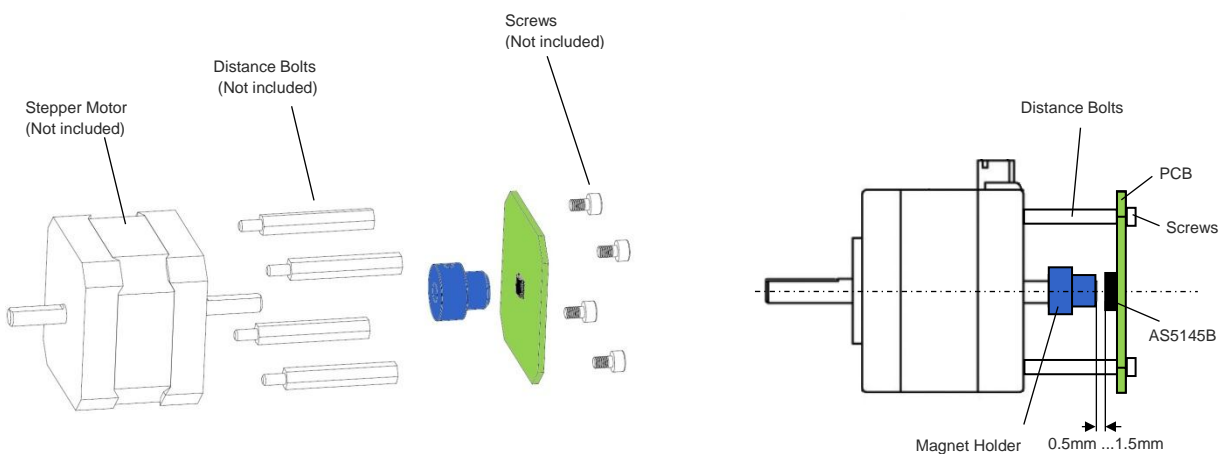

The AS5145B board can be mounted on double shaft motors. (See figure 4)

Screws and distance bolts are not included.

5. Schematics, Layout

Figure 5:
Schematic

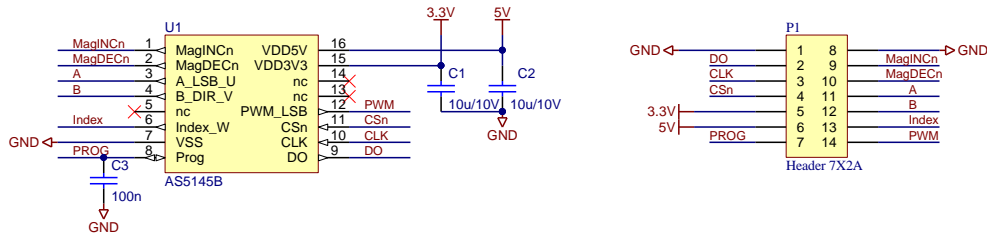

Figure 6:
Top Layer

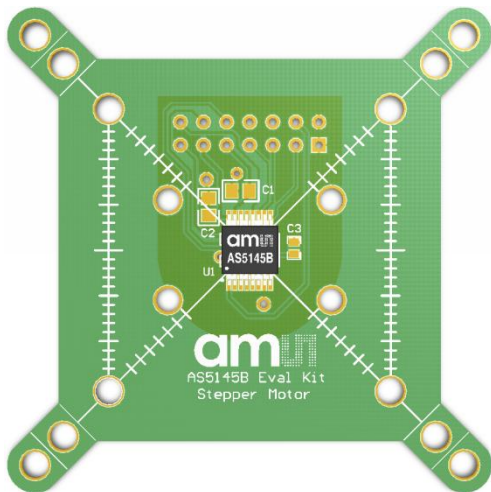

Figure 7:
Bottom Layer

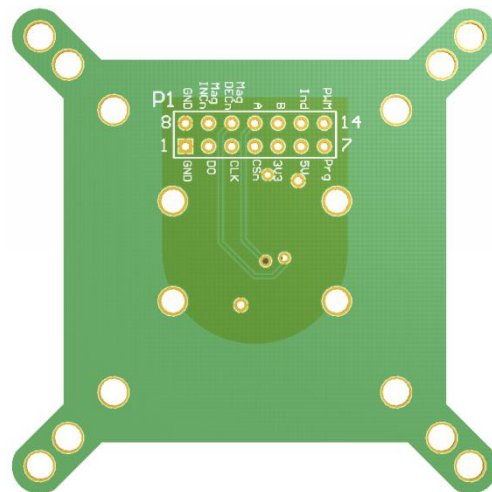

Table 4:
Bill of Materials

Pos	Part Number	Reference
1	PCB Board	PCB1
2	U1	AS5145B
3	C1	10uF/10V/0805
4	C2	10uF/10V/0805
5	C3	100nF/10V/0603
6	P1	14 Pin Header

Figure 8:
Magnet Holder



Grub screw for fixing
on the shaft of the
motor.

Figure 9:
Magnet Holder Dimensions

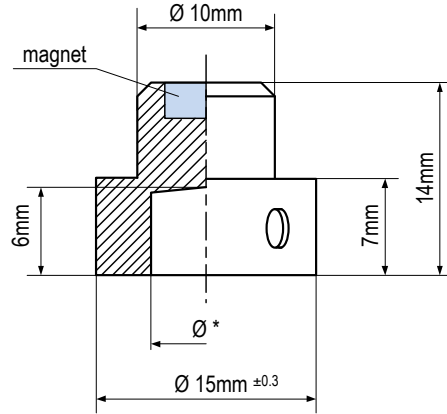

- *Ø 5mm
- *Ø 6mm
- *Ø 8mm
- *Ø 10mm

Figure 10:
Layout Dimensions

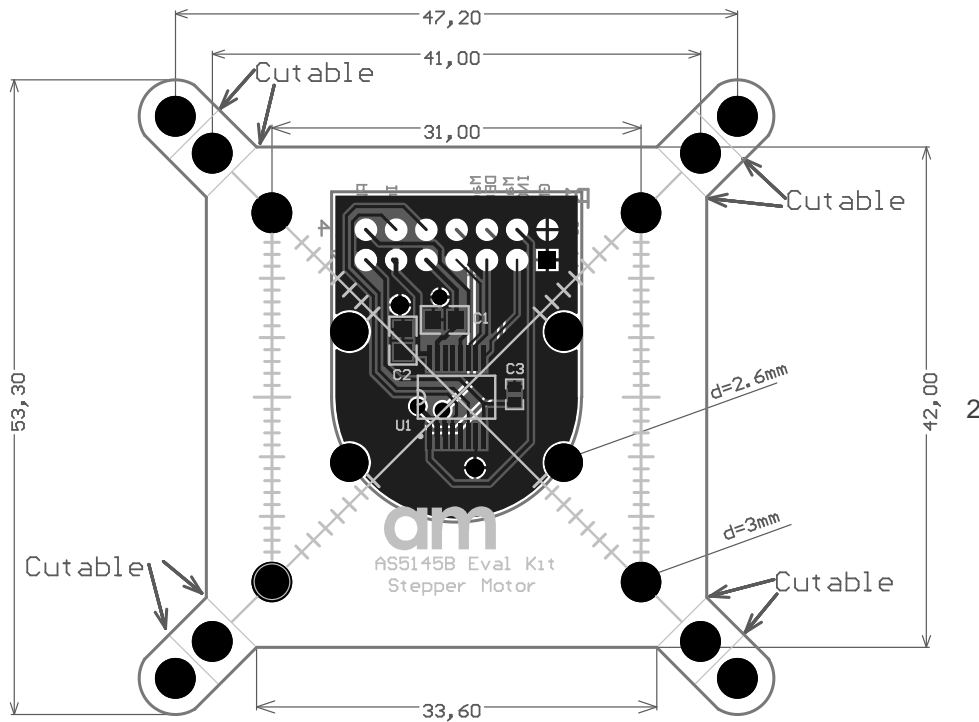

6. Ordering Information

Table 5:
Ordering Information

Ordering Code	Description
AS5145B-EK-AB-STM1.0	AS5145B Eval-Kit Stepper Motor with ABI, SSI, PWM

Revisions History

Revision	Date	Description
1.0	August 6, 2012	First version
1.1	Januar 23, 2014	Updated to new board design