

# Product Document



## User Guide

UG000402

# AS5x47U Motor Board

## Motor Board User Manual

AS5047U / AS5147U

v1-00 • 2021-Oct-01

---

# Content Guide

|          |                            |          |          |                                   |           |
|----------|----------------------------|----------|----------|-----------------------------------|-----------|
| <b>1</b> | <b>Introduction .....</b>  | <b>3</b> | 4.1      | Schematic .....                   | 8         |
| 1.1      | Kit Content.....           | 3        | 4.2      | PCB Layout .....                  | 9         |
| 1.2      | Ordering Information ..... | 4        | <b>5</b> | <b>Revision Information .....</b> | <b>10</b> |
| <b>2</b> | <b>Description.....</b>    | <b>5</b> | <b>6</b> | <b>Legal Information.....</b>     | <b>11</b> |
| 2.1      | Mounting on Motor .....    | 6        |          |                                   |           |
| <b>3</b> | <b>Pinout .....</b>        | <b>7</b> |          |                                   |           |
| <b>4</b> | <b>Hardware .....</b>      | <b>8</b> |          |                                   |           |

# 1 Introduction

The AS5x47U motor board is a simple PCB which is designed to adapt to standard size BLDC or stepper motors. It allows easy and quick evaluation of the AS5x47 magnetic position sensor family.

The sensor and all necessary external components are already soldered to the PCB.

## 1.1 Kit Content

Figure 1:  
AS5x47U Motor Board Kit Content

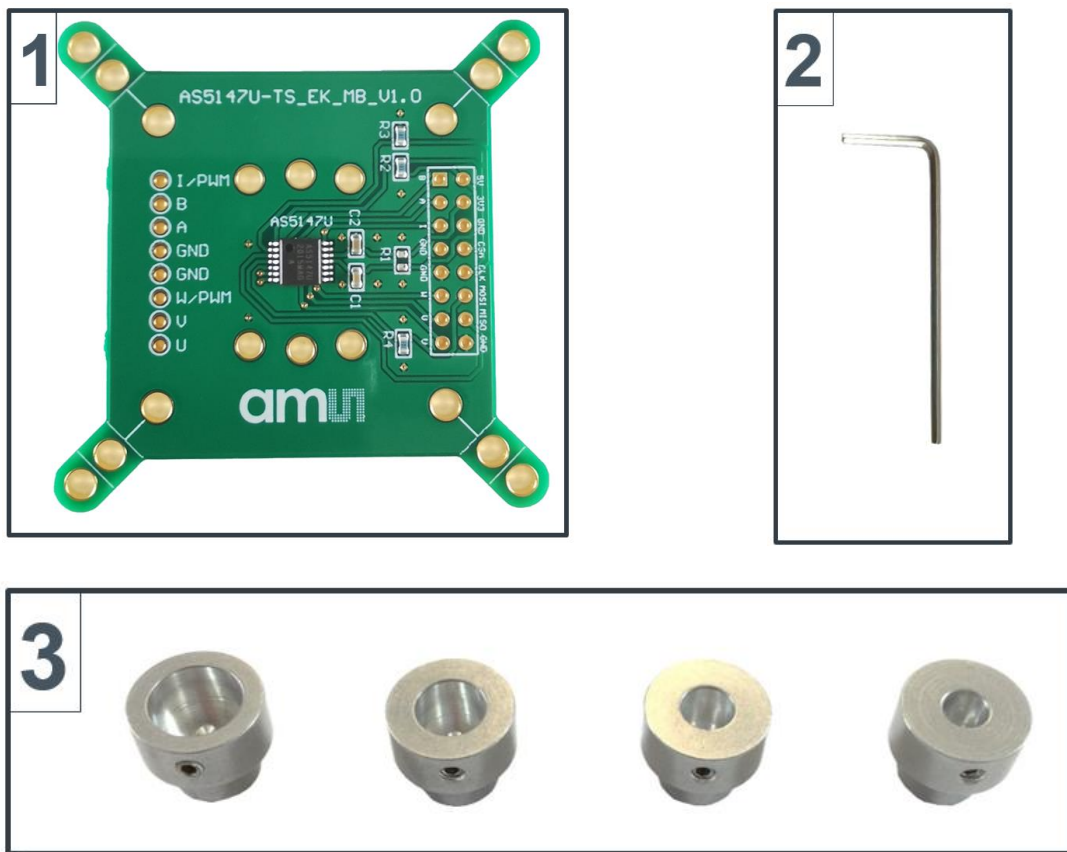

- 1 Motor Board
- 2 Allen Key
- 3 Magnet Holders

---

## 1.2 Ordering Information

| # | ITEM             | Description                    |
|---|------------------|--------------------------------|
| 1 | AS5x47U-TS_EK_MB | Motor Board                    |
| 2 | Allen key        | 1.5 mm                         |
| 3 | Magnet holders   | Diameters: 10mm, 8mm, 6mm, 5mm |

## 2 Description

The PCB can either be connected to an external microcontroller or to the USB I&P Box which is available on our webpage. (USB I&P Box)

P1 has to be populated with a 2x8 pin header and is required for power supply as well as SPI, ABI, UVW/PWM interfaces.

The resistor R1 allows to select between 5V or 3.3V operation. When R1 is shorted only 3.3V operation is possible.

Furthermore the test pins on the bottom of the PCB give easy access to incremental outputs (ABI and UVW) for probing and measuring with an oscilloscope.

**Figure 2 :**  
**Motor Board**

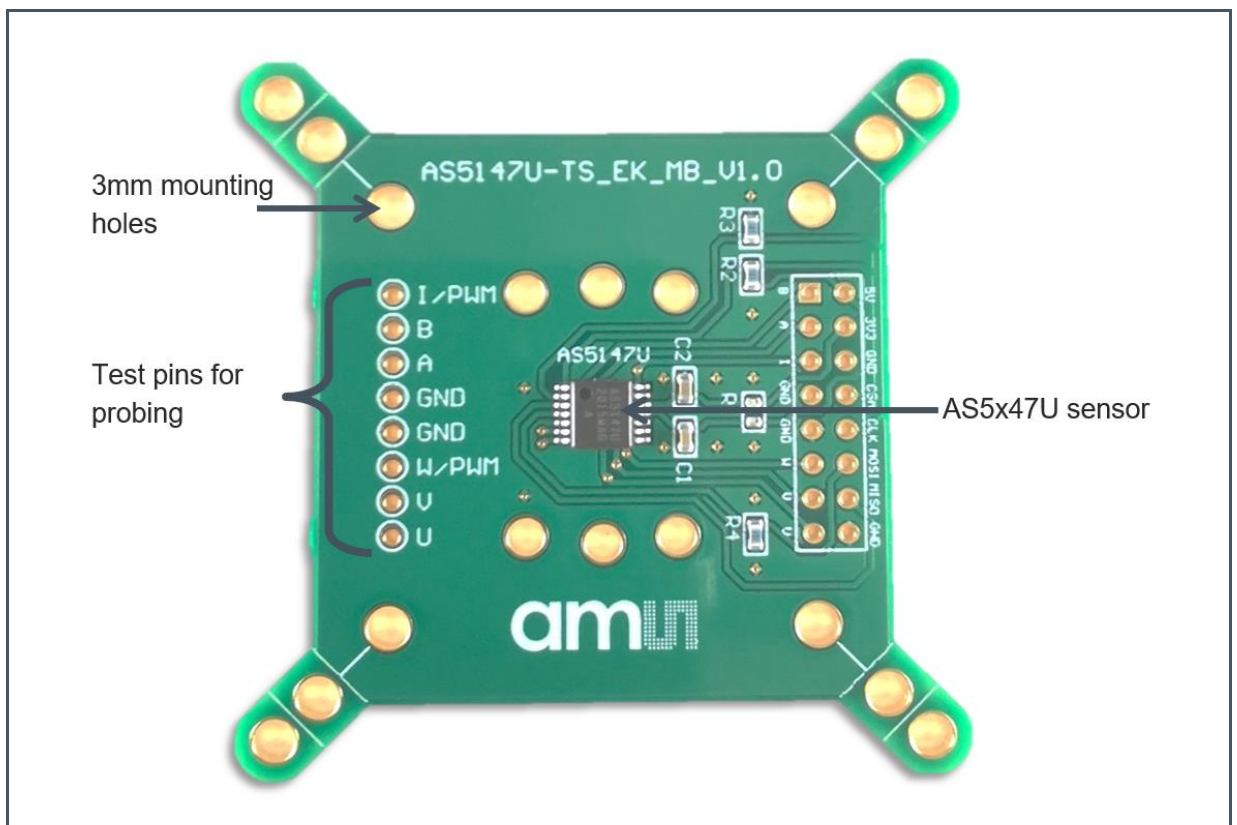

## 2.1 Mounting on Motor

Figure 3 :  
Mounting the AS5x47U Motor Board

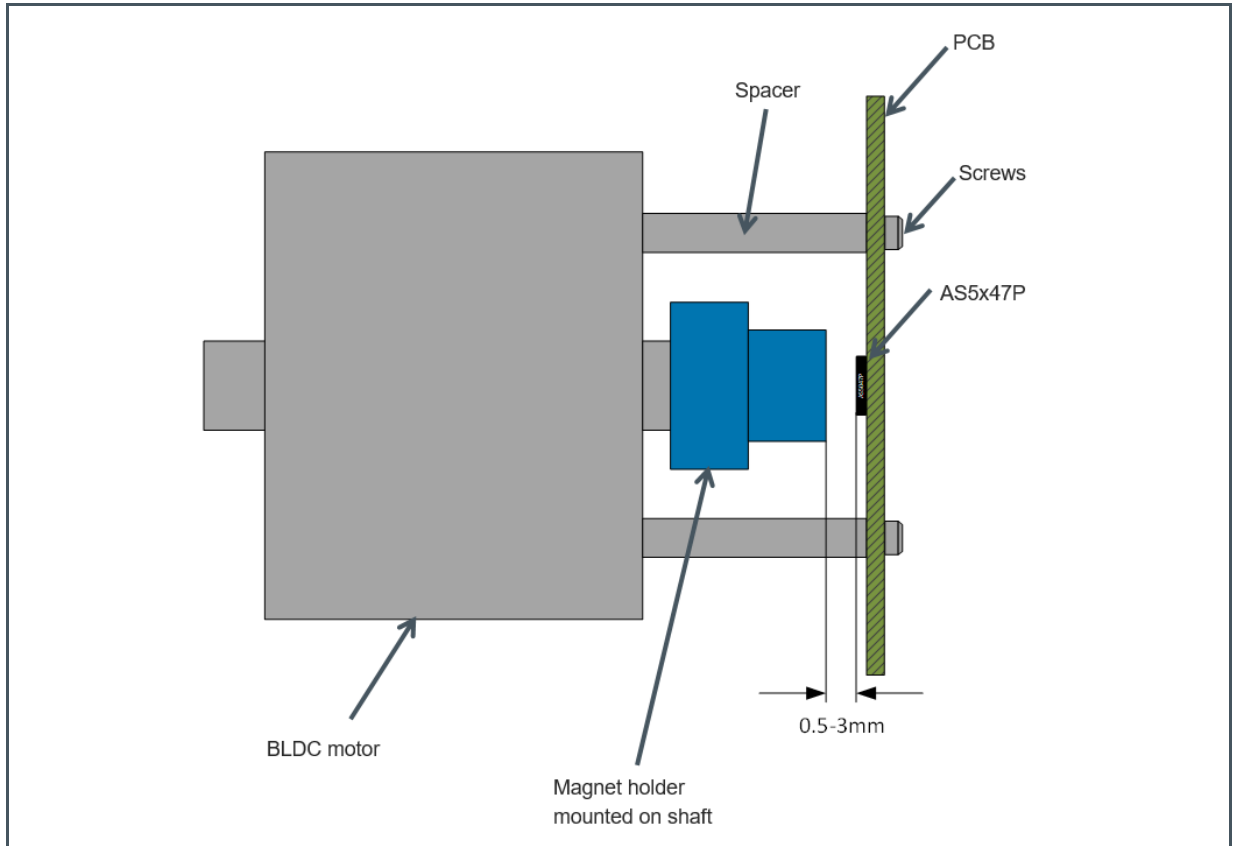

### 3 Pinout

Figure 4 :  
Pinout

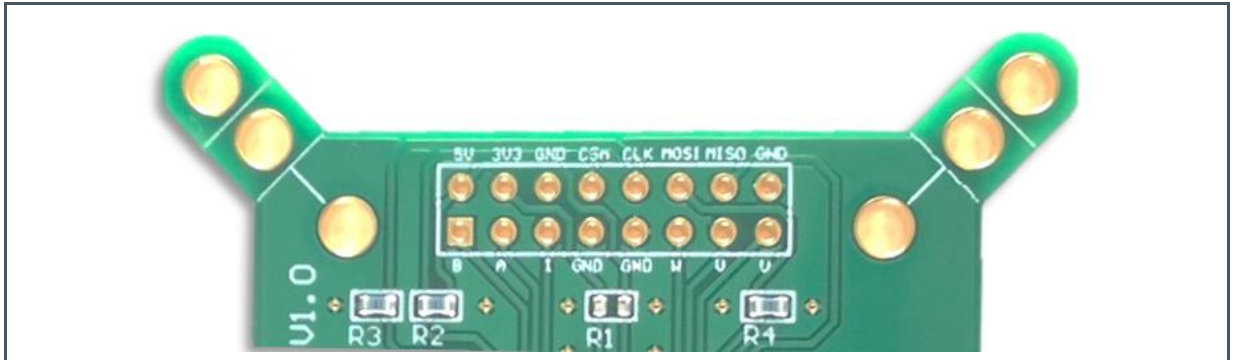

Figure 5:  
Pin Description

| Pin# Board | Symbol Board | Type           | Description                         |
|------------|--------------|----------------|-------------------------------------|
| P1 - 1     | A            | Digital output | Incremental signal A (quadrature)   |
| P1 - 2     | B            | Digital output | Incremental signal B (quadrature)   |
| P1 - 3     | I            | Digital output | Incremental signal I (index) or PWM |
| P1 - 4     | TEST         |                | Test pin (connect to ground)        |
| P1 - 5     | NC           |                | Not connected                       |
| P1 - 6     | U            | Digital output | Commutation signal U                |
| P1 - 7     | V            | Digital output | Commutation signal V                |
| P1 - 8     | W            | Digital output | Commutation signal W or PWM         |
| P1 - 9     | 5V           | Power supply   | Positive supply voltage             |
| P1 - 10    | 3V3          | Power supply   | 3.3V LDO output                     |
| P1 - 11    | NC           |                | Not connected                       |
| P1 - 12    | CSn          | Digital input  | SPI chip select (active low)        |
| P1 - 13    | CLK          | Digital input  | SPI Clock                           |
| P1 - 14    | MOSI         | Digital input  | SPI MOSI                            |
| P1 - 15    | MISO         | Digital output | SPI MISO                            |
| P1 - 16    | GND          | Power supply   | Ground                              |



# 4 Hardware

## 4.1 Schematic

Figure 6 :  
AS5x47U-TS\_EK\_MB Schematics

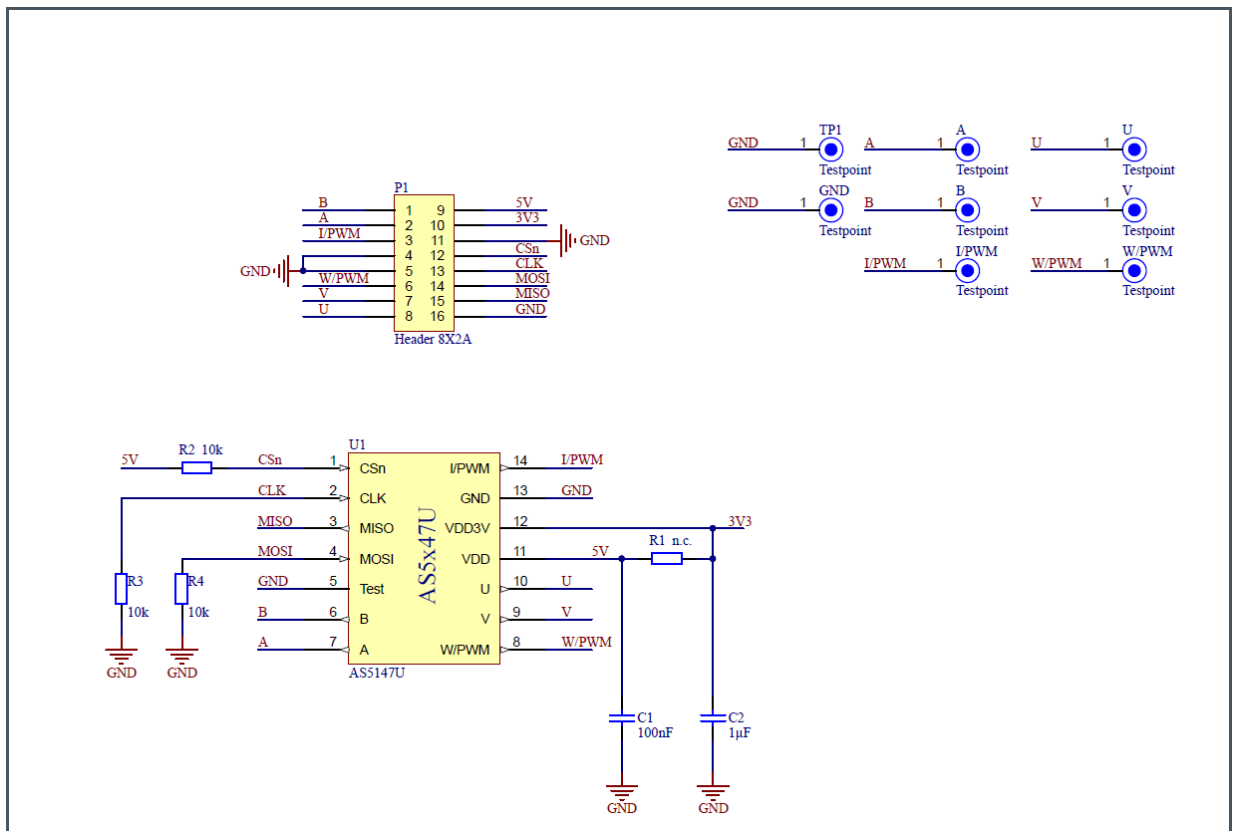

## 4.2 PCB Layout

Figure 7 :  
AS5x47U-TS\_EK\_MB PCB Layout

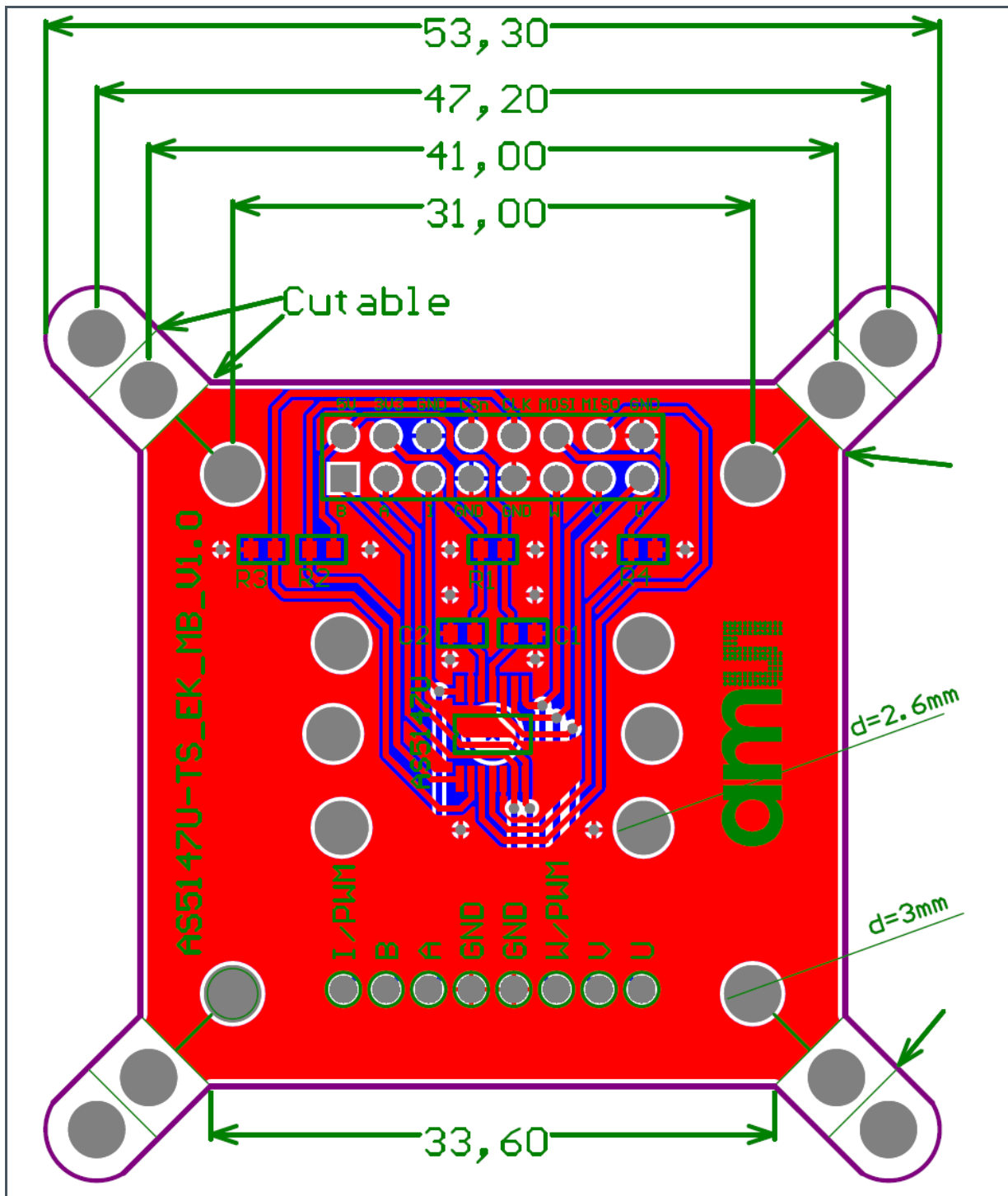

---

## 5 Revision Information

---

| Changes from previous version to current revision v1-00 | Page |
|---|------|
| Initial Version   |      |

---

- Page and figure numbers for the previous version may differ from page and figure numbers in the current revision.
- Correction of typographical errors is not explicitly mentioned.