



User Manual – AS5161 / AS5162 Adapterboard

AS5161-EK-AB / AS5162-EK-AB

12 BIT Magnetic Angle Position Sensor



Table of Contents

- 1. General Description 2
- 2. Package and Board Description 3
- 3. AS5161/ AS5162 and adapter board pin out 5
- 4. Operation case 6
- 5. Programming the AS5161 / AS5162 6
- 6. AS5161 /AS5162 adapter board hardware 7
- 7. Ordering Information..... 8
- Copyright..... 9
- Disclaimer 9

1. General Description

This document describes the features and operation of the AS5161 / AS5162 Adapterboard.

The AS5161 / AS5162 is a contactless magnetic angle position sensor for accurate angular measurement over a full turn of 360°. A sub range can be programmed to achieve the best resolution for the application. It is a system-on-chip, combining integrated Hall elements, analog front end, digital signal processing and best in class automotive protection features in a single device.

To measure the angle, only a simple two-pole magnet, rotating over the center of the chip, is required. The magnet may be placed above or below the IC.

The absolute angle measurement provides instant indication of the magnet's angular position with a resolution of $0.022^\circ = 16384$ positions per revolution. According to this resolution the adjustment of the application specific mechanical positions are possible. The angular output data is available over a 12 bit ratiometric analog output.

The AS5161 / AS5162 operates at a supply voltage of 5V and the supply and output pins are protected against overvoltage up to +20V. In addition the supply pins are protected against reverse polarity up to -20V

2. Package and Board Description

Adapterboard Kit Contents

The demo kit includes following items listed below in Table 1.

Table 1:
Adapter Kit Contents

Pos	Item	Comment
1	AS5161/AS5162 Adapterboard	Board + AS5161 or AS5162
2	Diametrial Magnets	

Board Description

The AS5161 / AS5162 adapter board is a simple circuit allowing test and evaluation the rotary encoder quickly without building a test fixture or PCB. The PCB requires only a 3-wire connection: 5V power supply, GND and the output connection . Only pin 1, 3, 5, and 7 of JP1 are connected. Capacitor C2 (1uF) is buffering the LDO output VDD3; C3 (1uF) is placed between VDD and GND.

Resistor R1 and R2 as well as the capacitor C4 and C5 are optional, for using different filter options during the Evaluation phase..

Figure 1
Adapterboard front view

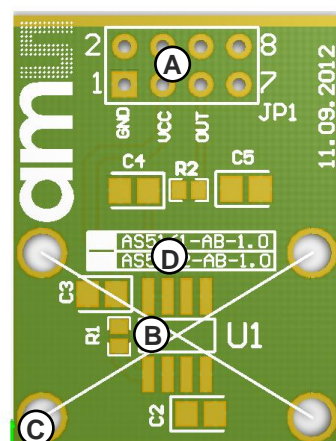

- (A) JP1 Connector
(GND,VCC,OUT)
- (B) AS5161 / AS5162 sensor
- (C) 4 x 2.6 mm mounting holes
- (D) Marking for AS5161 or AS5162 AB Board

Mounting the AS5161 / AS5162 adapter board

Figure 2
Adapter board with mechanical components

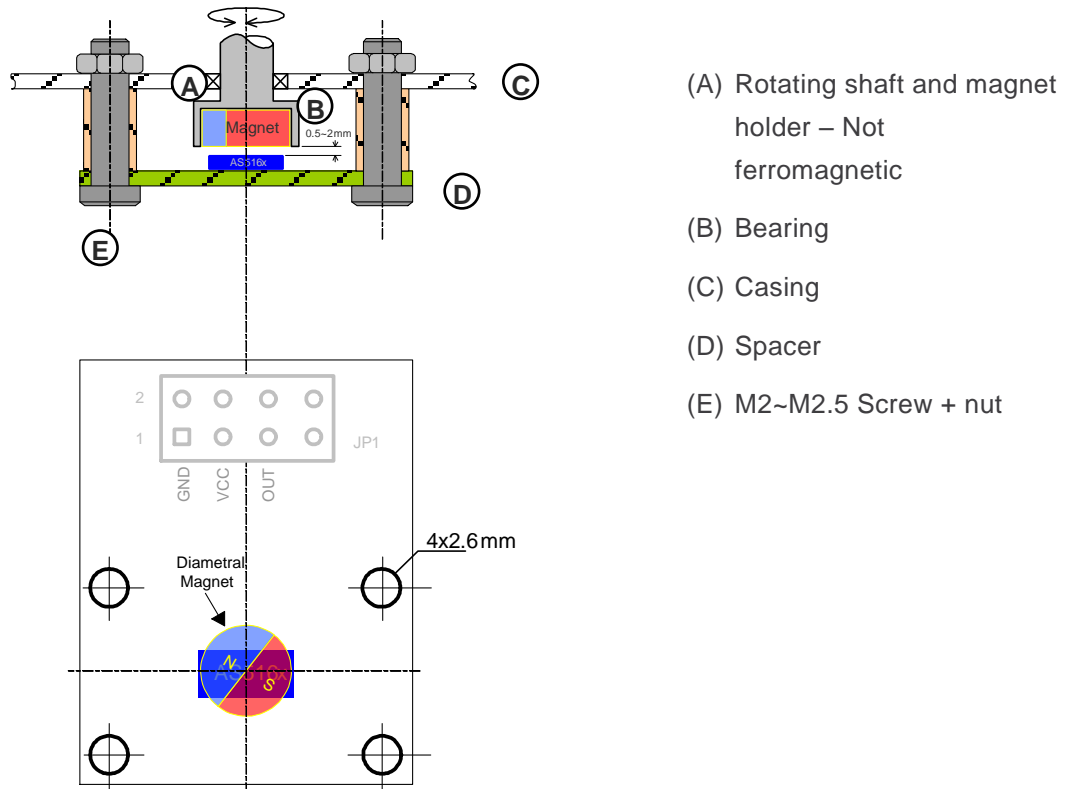

A diametric magnet must be placed over or under the AS5161 / AS5162 Adapterboard, and should be placed centered in x and y direction. Tolerance of 0.5mm

The airgap between the magnet and the encoder casing should be maintained in the range of 0.5mm~2mm (magnet related).

The magnet holder must be not ferromagnetic. e.g copper, aluminium, stainless steel.

3. AS5161/ AS5162 and adapter board pin out

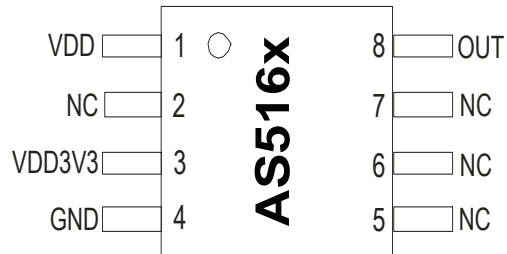
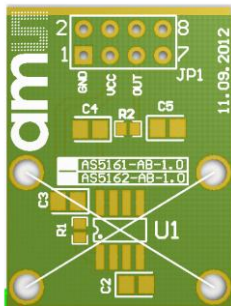

Figure 3 AS5161/AS5162 adapterboard connectors and sensor pinout

Table 2:
Pin Out

Pin# Board	Pin# AS5161/62	Symbol Board	Type	Description
JP1 - 1	2,4,5	GND	S	Supply ground
JP1 - 2				Not connected
JP1 - 3	1	VCC	S	Positive supply pin (overvoltage protected)
JP1 - 4				Not connected
JP1 - 5	15	OUT	DIO/AIO	Output and interface pin. Provides PWM Output on the AS5161 and Analogoutput on the AS5162 .It is as well used for programming UART interface
JP1 - 6				Not connected
JP1 - 7				Not connected
JP1 - 8				Not connected

4. Operation case

Figure 4 Operation Case example pull up.

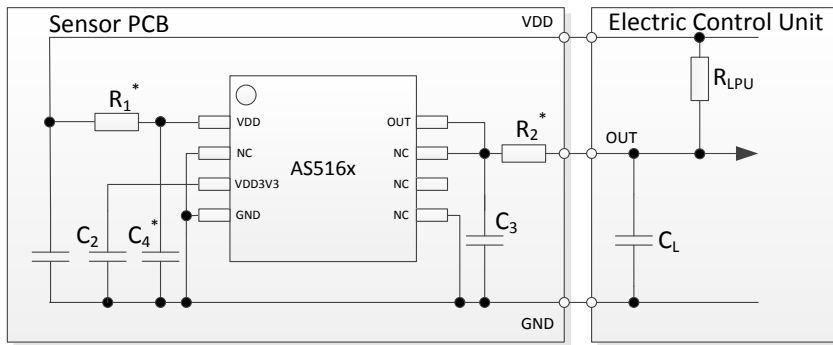

The OUT pin (JP1 – 5) is used as output as well as programming interface. After the first power up, the AS5161 or the AS5162 is in communication mode. During this mode different settings are possible to program via UART. After the fusing of the internal OTP (one time programmable) block, the AS5161 provides a pulse width modulated output (PWM) and the AS5162 provides an analog output,

Figure 5 shows the recommended schematic for AS5161 and AS5162 (pull up solution) in the application. All components marked with (*) are optional and can be used to further increase the EMC. For further information, please refer to datasheet.

5. Programming the AS5161 / AS5162

For programming of the AS5161 / AS5162 only 3 connections (VCC, GND and OUT) are necessary. The AS5161 / AS5162 programming is a one-time-programming (OTP) method, based on polysilicon fuses. The advantage of this method is that no additional programming voltage is needed. The internal LDO provides the current for programming.

The AS5161 / AS5162 uses a standard UART interface with an address byte and two data byte.

For programming the AS5161 / AS5162 there is a DemoSoftware (Executable Labview) and an easy UART-Interfaceboard available.

6. AS5161 /AS5162 adapter board hardware

AS5161-EK-AB and AS5162-EK-AB Schematic

Figure 5

Adapterboard Schematic

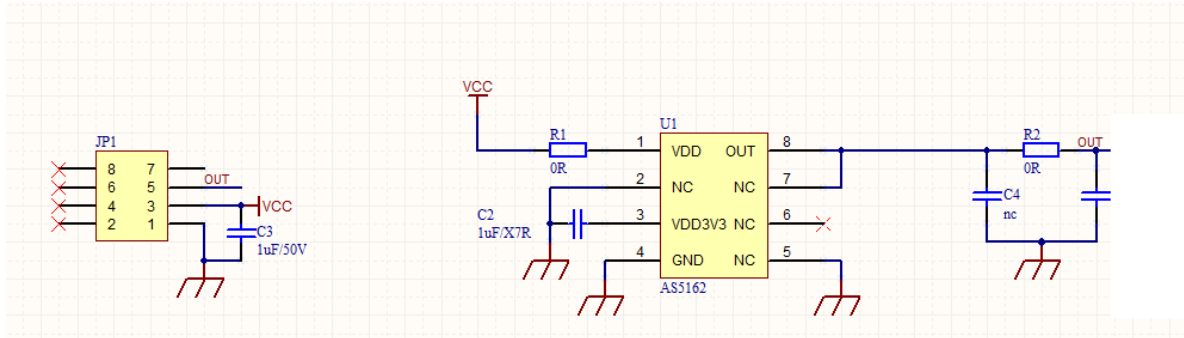

AS5161-EK-AB and AS5162-EK-AB PCB layout

Figure 6:

Adapterboard Layout

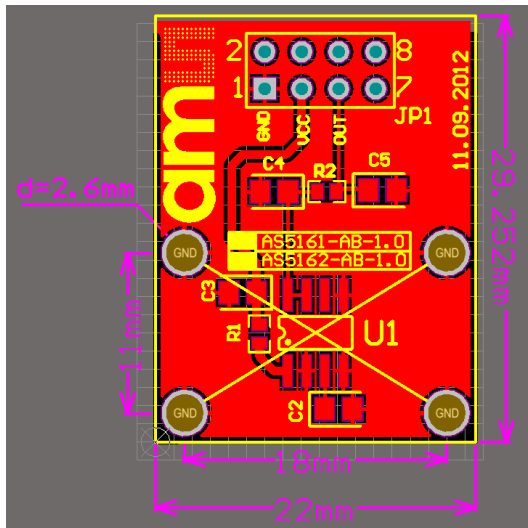

7. Ordering Information

Table 3:
Ordering Information

Ordering Code	Description	comments
AS5161-EK-AB	AS5161 Adapterboard	3 diametric magnets
AS5162-EK-AB	AS5162 Adapterboard	3 diametric magnets