



Operation Manual: AS5600-SO_EK_AB

AS5600

12-bit Programmable Contactless Potentiometer

Table of Contents

1	General Description	3
1.1	Kit Content	3
2	Getting Started	3
2.1	Adapter Board Pin-Out.....	3
2.2	Adapter Board Description.....	4
2.3	Mechanical Setup.....	5
2.4	Electrical Setup	5
2.4.1	3-Wire Mode.....	5
2.4.2	I ² C Mode	6
3	AS5600 Configuration	6
3.1	Programming the output range	6
3.2	Programming a configuration.....	6
3.2.1	Low Power Mode	7
3.2.2	Hysteresis	7
3.2.3	Output selection	7
3.2.4	Slow Filter	7
3.2.5	Fast Filter	7
3.2.6	Watchdog	7
4	Board Schematics, Layout and BOM.....	7
4.1	Schematics.....	7
4.2	Layout and Board Dimensions.....	8
4.3	Bill of Materials.....	8
5	Evaluation tools.....	9
6	Ordering Information	9
	Copyright	10
	Disclaimer.....	10

Revision History

Revision	Date	Owner	Description
1.0	05.05.2014	rph	Initial Revision
1.1	01.08.2014	rph	Updated Schematic
1.2	18.11.2014	rph	Updated Table 2: Adapterboard Pinout
1.3	02.12.2014	azen	Updated Figure 1,3,4 and Table 3

1 General Description

The adapter board allows an easy and fast evaluation of the AS5600 rotary magnetic position sensor in the lab or together with an existing system. This small factor board is fully assembled with AS5600 position sensor and its necessary external components. All relevant signals are available on a dual-row 2.54mm 4-pin header footprint and can be easily wired to an existing application.

The AS5600 is a programmable Hall-based rotary magnetic position sensor with a high-resolution 12-bit analog or PWM output for contactless potentiometers. Based on planar Hall technology, this device measures the orthogonal component of the flux density (Bz) from an external magnet while rejecting stray magnetic fields.

The default range of the output is 0 to 360 degrees, but the full resolution of the device can be applied to smaller range by programming a zero angle (start position) and maximum angle (stop position).

The I²C interface is used for configuration and user programming of non-volatile parameters in the AS5600. Additionally the device can be programmed in 3-wire mode without any programmer.

1.1 Kit Content

This kit contains following material listed in Table 1. Additional material can be found on our webpage.

Table 1:
Kit Content

No.	Item	Description	Info
1	AS5600-SO_EK_AB	Adapterboard	
2	AS5000-MD6H-1	Reference Magnet	Find the datasheet online at http://ams.com/eng/AS5000-MD6H-1

2 Getting Started

The AS5600 adapter board is ideal for rapid setup of a contactless potentiometer. Additionally to the adapter board, a sensor magnet in a mechanical setup is required. A reference magnet comes with the kit.

2.1 Adapter Board Pin-Out

The pin-out of the adapter board is shown in Table 2. For additional information on the AS5600 pins refer to the product datasheet.

Table 2:
Adapter Board Pin-Out

Header	Pin	Symbol	Description	Info
J3	1	SCL	I2C Clock	Use R4 if pull-up is required
J3	2	SDA	I2C Data	Use R4 and R5 if pull-up is required
J3	3	GND	Ground	
J3	4	VDD	Positive Power Supply	
J2	1	VRG	LDO Pin in 5V Mode	Leave open in 5V mode. Pull to VDD using J1 in 3.3V Mode
J2	2	PGO	Programming Mode	Pull to GND using R3 for Programming Option B (refer to the datasheet)
J2	3	DIR	Direction input	CCW default. Pulled to GND using R2. Remove R2 and insert at R1 for CCW direction.
J3	4	OUT	Output Pin	Analog Output default, PWM possible, Is used for programming option B

2.2 Adapter Board Description

The AS5600 is connected over the dual-row 2.54mm 4-pin header footprint. Connect the desired pins of the AS5600 using the headers and resistors.

Figure 1:
Adapterboard Description

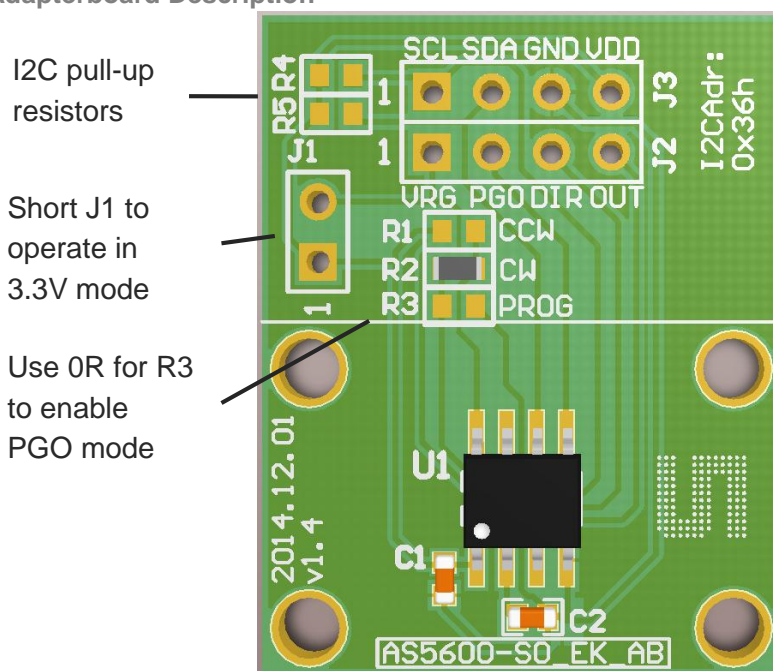

2.3 Mechanical Setup

To set up a contactless potentiometer a magnet holder and a magnet are needed to be used with the AS5600 position sensor on a PCB. The configuration is shown in Figure 2.

Figure 2:
 Mechanical Configuration

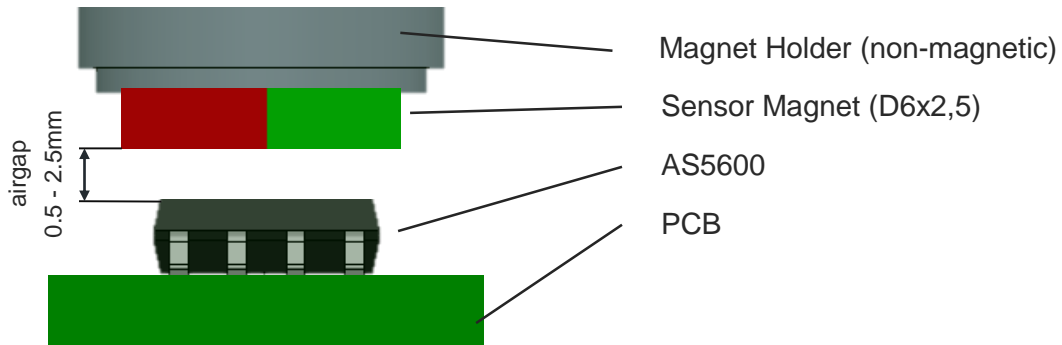

The magnet should be aligned by reading the output of the AGC register of the AS5600. For optimal alignment, the AGC value is in the middle of the AGC range.

Note: If the magnetic field seen by the AS5600 is below 8mT, the output is switched off and permanent angle programming is not possible.

2.4 Electrical Setup

The adapterboard is many used in following configurations in 5V or in 3.3V mode.:

2.4.1 3-Wire Mode

In this mode, the power supply and the output pin of the adapterboard are connected. To program a custom angular output range, short R3 using a 0R resistor to enable the programming option B. Follow the step-by-step instructions in the AS5600 datasheet to program the device.

Figure 3:
 Using the board in 3-Wire Mode

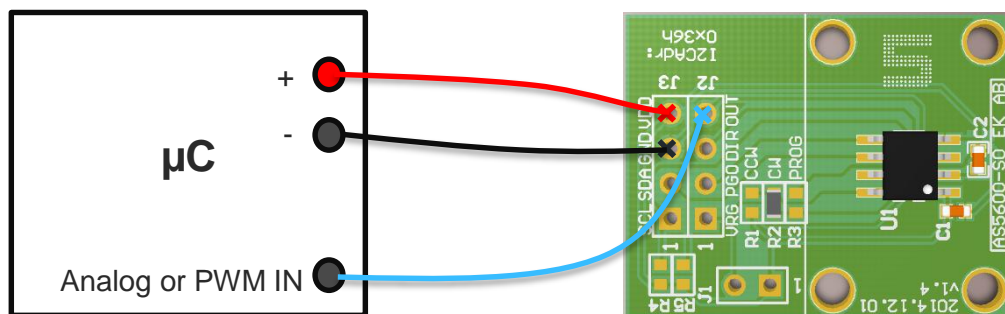

2.4.2 I²C Mode

Using the I2C Interface, all functions of the AS5600 can be configured and permanently programmed. Additionally the output and a raw angle (unmodified value) can be read from the output registers.

Figure 4:
Using the board in I2C Mode

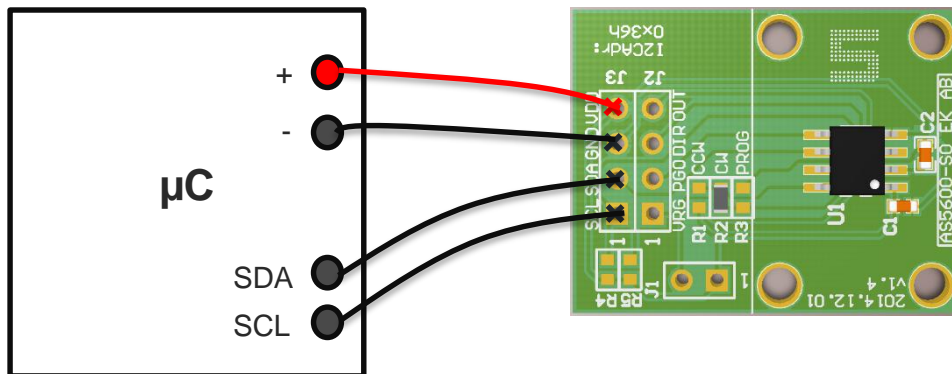

3 AS5600 Configuration

All options to configure the AS5600 are shown below. The AS5600 operates with a default configuration if no configuration was programmed.

3.1 Programming the output range

To adjust a custom angle to the full output range or to modify the Zero Position of the device, the AS5600 must be programmed. Following options are available:

- Programming start and stop position with I²C (Option A)
- Programming start and stop position in 3-Wire Mode (Option B)
- Programming an angular excursion with I²C (Option C)

Follow the step-by-step instructions in the AS5600 datasheet for one of the above programming options.

Note: To program only the zero position with Option B, Program an angular excursion of 360deg using Option C first.

3.2 Programming a configuration

A configuration must be written using the I2C interface. The Burn_Setting command (Write 0x40 into register 0xFF) can be used to permanently program a configuration.

3.2.1 Low Power Mode

Three low power modes are available to reduce the power consumption down to 1,5mA max.

3.2.2 Hysteresis

A 1 to 3 LSB hysteresis of the 12-bit resolution can be enabled.

3.2.3 Output selection

Per default, the Analog Output is active if a magnet is present. Additionally the Output Pin can be switched to PWM with the option to select a PWM frequency (115Hz,230Hz,460Hz,920Hz)

3.2.4 Slow Filter

The slow filter allows improving the output noise. The default setting for the Slow Filter is 16x and can be reduced for faster response.

3.2.5 Fast Filter

The fast filter is active by selecting a Fast Filter Threshold. If the output value remains below the threshold, the output noise is defined by the slow filter setting. When exceeding the threshold, the output noise is defined from the fast filter for fast output response. The output noise is again defined by the slow filter as soon as the output stays in the threshold again.

3.2.6 Watchdog

If the watchdog is active, the AS5600 automatically enters Low Power Mode 3 after one minute if the output value stays within a threshold of 4 LSB.

4 Board Schematics, Layout and BOM

The schematic, layout and BOM of the adapterboard are shown below for reference.

4.1 Schematics

The schematic of the board is shown below in Figure 5.

Figure 5:
Adapterboard Schematic

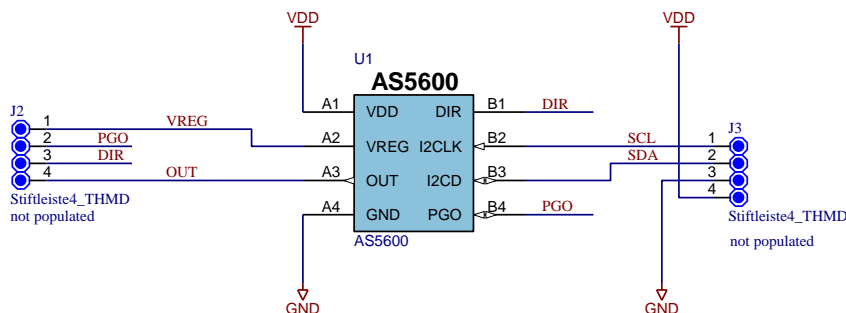

Note1: Supply
J1=OPEN: 5V
J1=CLOSED: 3.3V

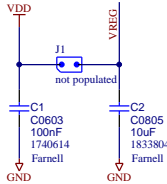

Note2: PGO
R3=NC: Normal Operation
R3=0R: Programming Option



Note3: Direction
R1=NC/R2=0R: CW
R1=0R/R2=NC: CCW

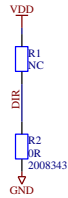

Note4: Optional pull-ups

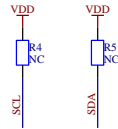

Note5:
Adapterboard can be used with AS5XXX-UCB-1.0
(Use 4pin I2C header in 3.3V mode)

Note6:
AS5600 I2C Address is 0x36h

4.2 Layout and Board Dimensions

The PCB layout is shown below in Figure 6.

Figure 6:
Adapterboard layout

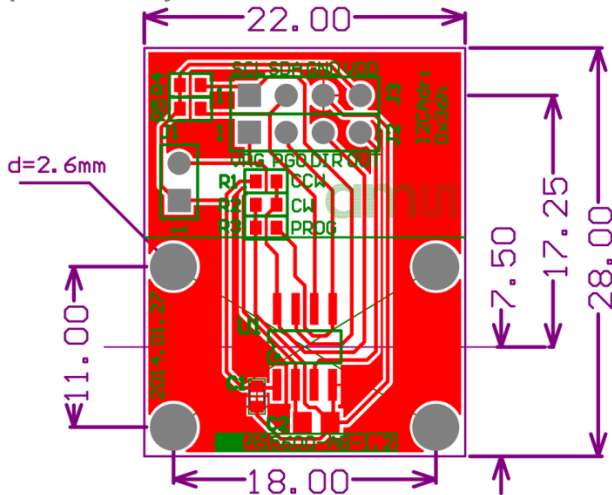

4.3 Bill of Materials

The BOM of the pcb is below in Table 3.

Table 3:
Bill of Materials

Designator	Part	Footprint	Manufacturer	Comment
J1	Jumper			
J2	Header			
J3	Header			
R1	Resistor / not populated	R0603		
R2	0R	R0603		clockwise direction default
R3	Resistor / not populated	R0603		
C1	C0603	0603		
C2	C0603	0603		

Designator	Part	Footprint	Manufacturer	Comment
R4	Resistor / not populated	R0603		
R5	Resistor / not populated	R0603		
U1	AS5600	SOIC-8	amsAB	Smart Potentiometer IC

5 Evaluation tools

To configure the AS5600, no dedicated programmer is needed. For fast setup time the USB I&P Box can be used to configure the AS5600 over I²C. The USB I&P Box can be ordered from the ams webpage.

Additionally a magnet holder kit is available with consist of a distance block and a Knob which holds the sensor magnet.

Please find the ordering information below in Table 4.

Table 4:
Ordering Information for Evaluation Tools

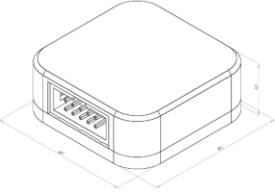
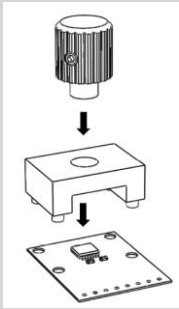
Ordering Code	Description	Image
USB I&P Box	To configure the AS5600	
RMH05-DK-XX-1.0	Rotary Magnet Holder for adapterboard	

6 Ordering Information

Please find the ordering information below in Table 5.

Table 5:
Ordering Information

Ordering Code	Description	Comments
AS5600-SO_EK_AB	AS5600 Adapterboard	For rapid evaluation and prototyping

Get additional support material online at <http://www.ams.com/AS5600>.