



**Operation Manual: AS5600-SO\_RD\_ST**

# **AS5600**

**12-bit Programmable Contactless Potentiometer**

## Table of Contents

1	General Description .....	3
1.1	Kit Content .....	3
2	Getting Started .....	3
2.1	Adapter Board Pin-Out.....	3
2.2	Adapter Board Description.....	4
2.3	Mechanical Setup.....	5
2.4	Electrical Setup .....	6
2.4.1	3-Wire Mode.....	6
2.4.2	I <sup>2</sup> C Mode .....	6
3	AS5600 Configuration .....	7
3.1	Programming the output range .....	7
3.2	Programming a configuration.....	7
3.2.1	Low Power Mode .....	7
3.2.2	Hysteresis .....	7
3.2.3	Output selection .....	7
3.2.4	Slow Filter .....	7
3.2.5	Fast Filter .....	7
3.2.6	Watchdog .....	8
4	Board Schematics, Layout and BOM.....	8
4.1	Schematics.....	8
4.2	Layout and Board Dimensions.....	8
4.3	Bill of Materials.....	9
5	Evaluation tools.....	10
6	Ordering Information .....	10
	Copyright .....	11
	Disclaimer.....	11

## Revision History

Revision	Date	Owner	Description
1.0	30.06.2014	rph	Initial Revision

## 1 General Description

The reference design allows an easy and fast evaluation of the AS5600 rotary magnetic position sensor in the lab. Additionally it is possible to replace an existing potentiometer with the AS5600-SO\_RD\_ST. The module is fully assembled with and pcb including the AS5600 position sensor and its necessary external components. All relevant signals are available on a 7-way connector Connector and can be easily wired to an existing application. Additionally there are tree-pin header to replace existing potentiometers.

The AS5600 is a programmable Hall-based rotary magnetic position sensor with a high-resolution 12-bit analog or PWM output for contactless potentiometers. Based on planar Hall technology, this device measures the orthogonal component of the flux density (Bz) from an external magnet while rejecting stray magnetic fields.

The default range of the output is 0 to 360 degrees, but the full resolution of the device can be applied to smaller range by programming a zero angle (start position) and maximum angle (stop position).

The I<sup>2</sup>C interface is used for configuration and user programming of non-volatile parameters in the AS5600 without requiring a dedicated programmer.

### 1.1 Kit Content

This kit contains following material listed in Table 1. Additional material can be found on our webpage.

Table 1:  
Kit Content

No.	Item	Description	Info
1	AS5600-SO_RD_ST		Reference Module including PCB
2	Quick Start Guide		

## 2 Getting Started

The AS5600 reference design is a contactless potentiometer. It can be programmed in 3-Wire Mode or over I<sup>2</sup>C.

### 2.1 Adapter Board Pin-Out

The pin-out of the adapter board is shown in Table 2. For additional information on the AS5600 pins refer to the product datasheet.

Table 2:  
Adapter Board Pin-Out (J1)

Pin	Symbol	Description	Info
-----	--------	-------------	------

Pin	Symbol	Description	Info
1	VDD	Positive Power Supply	
2	OUT	Output Pin	Analog Output default, PWM possible, Is used for programming option B
3	DIR	Direction input	CCW default. Pulled to GND using R2. Remove R2 and insert at R1 for CCW direction.
4	PGO	Programming Mode	Pull to GND using R4 for Programming Option B (refer to the datasheet)
5	SDA	I2C Data	
6	SCL	I2C Clock	
7	GND	Ground	

Table 3:  
Adapter Board Pin-Out (J2)

Pin	Symbol	Description	Info
1	VDD	Positive Power Supply	
2	OUT	Output Pin	Analog Output default, PWM possible, Is used for programming option B
7	GND	Ground	

## 2.2 Adapter Board Description

The AS5600 is connected over the 7-way header or by using the 3-Wire Mode. Connect the desired pins of the AS5600 using the headers and resistors.

Figure 1:  
AS5600-SO\_RD\_ST PCB Description

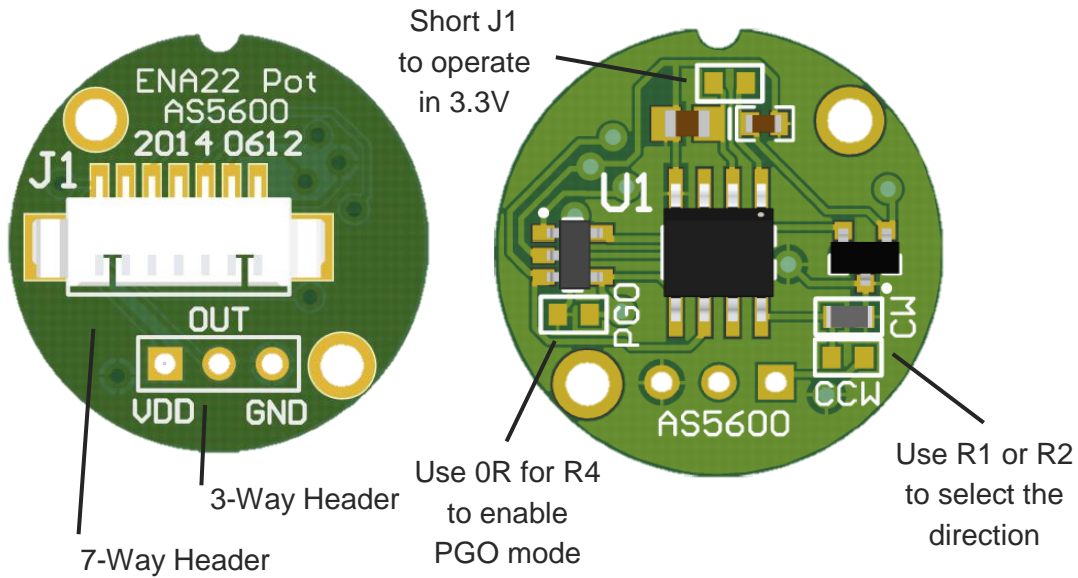

### 2.3 Mechanical Setup

The contactless potentiometer reference design comes with the AS5600-SO\_RD\_ST PCB assembled. The PCB holds all necessary components to operate the AS5600 in a contactless potentiometer application. The configuration of the reference module is shown in Figure 2.

Figure 2:  
Mechanical Configuration

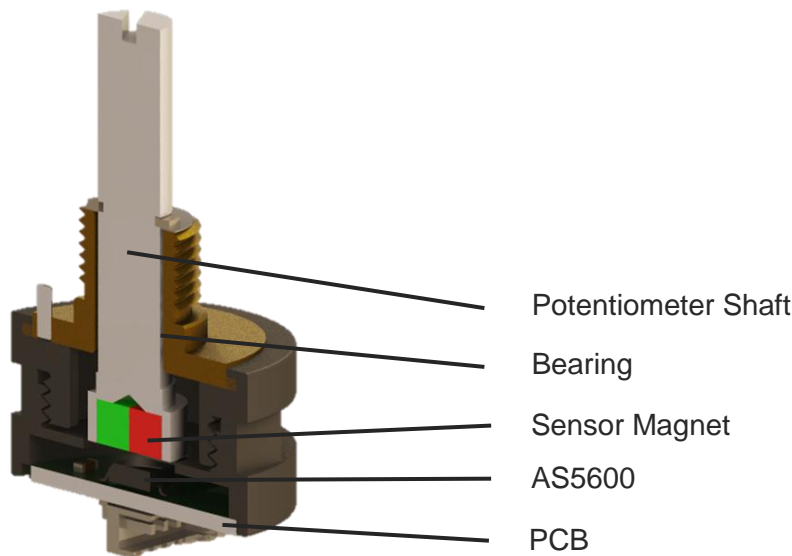

The magnet is already aligned to get AGC values in the middle of the AGC range.

**Note:** If the magnetic field seen by the AS5600 would be below 8mT, the output would be switched off and permanent angle programming would not be possible.

## 2.4 Electrical Setup

The reference module is many used in following configurations in 5V or in 3.3V mode.:

### 2.4.1 3-Wire Mode

In this mode, the power supply and the output pin of the reference module are connected. To program a custom angular output range, short R4 using a 0R resistor to enable the programming option B. Follow the step-by-step instructions in the AS5600 datasheet to program the device.

Figure 3:  
Using the board in 3-Wire Mode

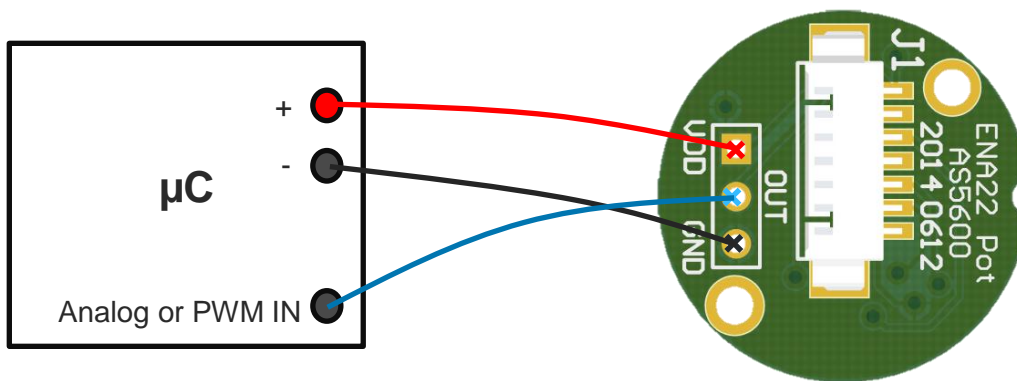

### 2.4.2 I<sup>2</sup>C Mode

Using the I2C Interface, all functions of the AS5600 can be configured and permanently programmed. Additionally the output and a raw angle (unmodified value) can be read from the output registers.

Figure 4:  
Using the reference module in I2C Mode

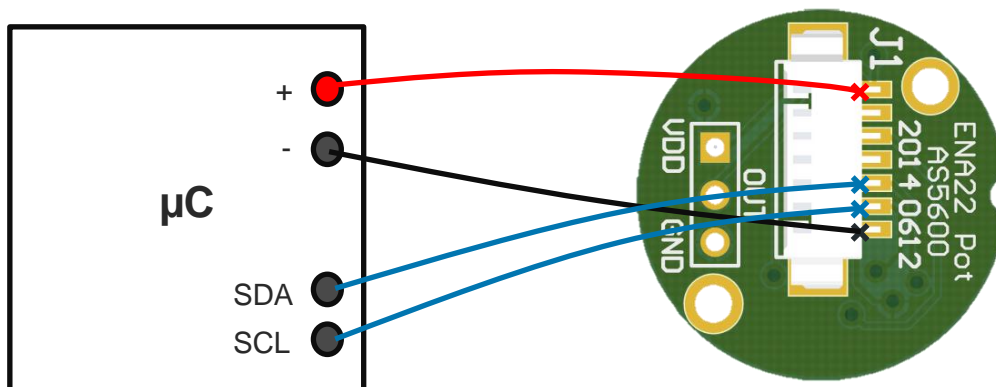

### 3 AS5600 Configuration

All options to configure the AS5600 are shown below. The AS5600 operates with a default configuration if no configuration was programmed.

#### 3.1 Programming the output range

To adjust a custom angle to the full output range or to modify the Zero Position of the device, the AS5600 must be programmed. Following options are available:

- Programming start and stop position with I<sup>2</sup>C (Option A)
- Programming start and stop position in 3-Wire Mode (Option B)
- Programming an angular excursion with I<sup>2</sup>C (Option C)

Follow the step-by-step instructions in the AS5600 datasheet for one of the above programming options.

**Note:** To program only the zero position with Option B, Program an angular excursion of 360deg using Option C first.

#### 3.2 Programming a configuration

A configuration must be written using the I2C interface. The Burn\_Setting command (Write 0x40 into register 0xFF) can be used to permanently program a configuration.

##### 3.2.1 Low Power Mode

Three low power modes are available to reduce the power consumption down to 1,5mA max.

##### 3.2.2 Hysteresis

A 1 to 3 LSB hysteresis of the 12-bit resolution can be enabled.

##### 3.2.3 Output selection

Per default, the Analog Output is active if a magnet is present. Additionally the Output Pin can be switched to PWM with the option to select a PWM frequency (115Hz,230Hz,460Hz,920Hz)

##### 3.2.4 Slow Filter

The slow filter allows improving the output noise. The default setting for the Slow Filter is 16x and can be reduced for faster response.

##### 3.2.5 Fast Filter

The fast filter is active by selecting a Fast Filter Threshold. If the output value remains below the threshold, the output noise is defined by the slow filter setting. When exceeding the threshold, the output noise is defined from the fast filter for fast output response. The output noise is again defined by the slow filter as soon as the output stays in the threshold again.

### 3.2.6 Watchdog

If the watchdog is active, the AS5600 automatically enters Low Power Mode 3 after one minute if the output value stays within a threshold of 4 LSB.

## 4 Board Schematics, Layout and BOM

The schematic, layout and BOM of the adapterboard are shown below for reference.

### 4.1 Schematics

The schematic of the board is shown below in Figure 5.

Figure 5:  
Reference Module PCB Schematic

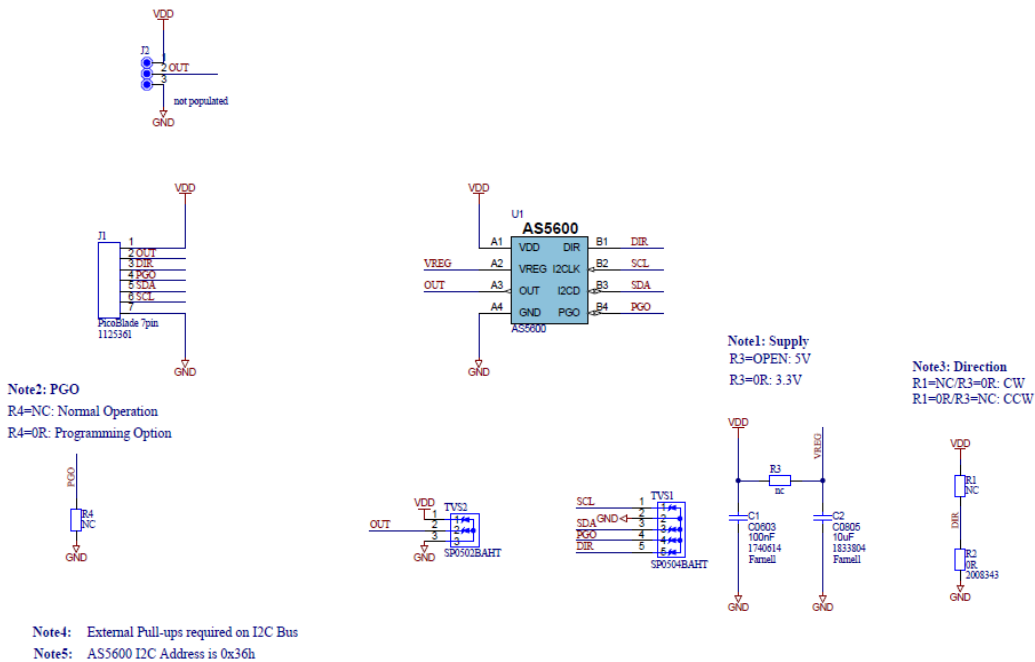

### 4.2 Layout and Board Dimensions

The PCB layout is shown below in Figure 6.



Figure 6:  
Reference Module PCB layout

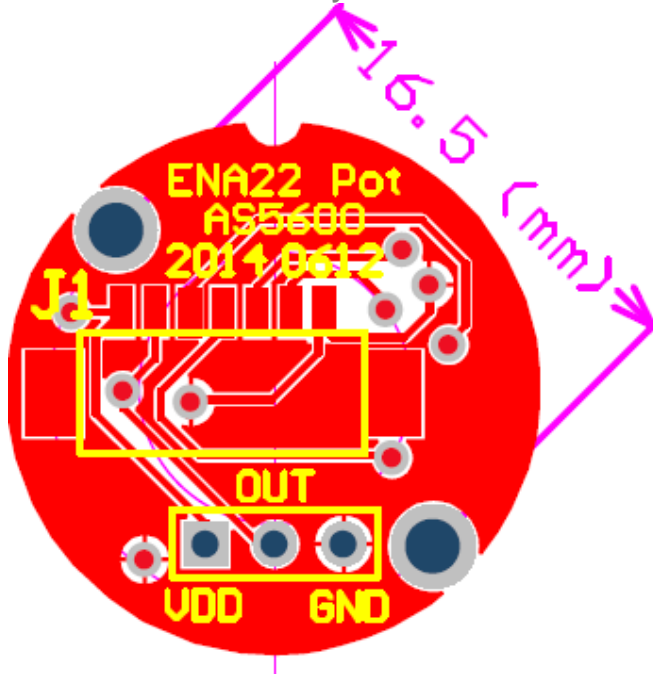

### 4.3 Bill of Materials

The BOM of the pcb is below in Table 4.

Table 4:  
Bill of Materials

Designator	Part	Footprint	Manufacturer	Comment
J1	Picoblade 7 Pin	Picoblade 7 Pin		
J2	Header / not populated			
R1	Resistor / not populated	R0603		
R2	0R	R0603		clockwise direction default
R3	Resistor / not populated	R0603		
C1	C0603	0603		
C2	C0805	0805		
TVS1	SP0504BAHT	SP0504BAHT-SOT23		
TVS2	SP0502BAHT	SP0502BAHT-SOT23		
R4	Resistor / not populated	R0603		
U1	AS5600	SOIC-8	amsAB	Smart Potentiometer IC

## 5 Evaluation tools

To configure the AS5600, no dedicated programmer is needed. For fast setup time the USB I&P Box can be used to configure the AS5600 over I<sup>2</sup>C. The USB I&P Box can be ordered from the ams webpage.

Please find the ordering information below in Table 5.

Table 5:

**Ordering Information for Evaluation Tools**

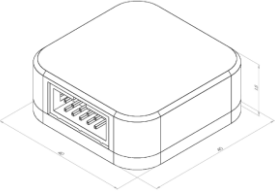
Ordering Code	Description	Image
USB I&P Box	To configure the AS5600	

## 6 Ordering Information

Please find the ordering information below in Table 6.

Table 6:

**Ordering Information**

Ordering Code	Description	Comments
AS5600-SO_RD_ST	AS5600 Reference Module	For rapid evaluation and prototyping

Get additional support material online at <http://www.ams.com/AS5600>.