

# Product Document



## **User Guide**

UG000345

# **AS5600L**

## **Adapter Board**

AS5600L-WL\_EK\_AB

v2-00 • 2021-Nov-16

---

# Content Guide

<b>1</b>	<b>Introduction .....</b>	<b>3</b>	<b>5</b>	<b>AS5600L-WL_EK_AB Hardware ...</b>	<b>8</b>
1.1	Kit Content.....	3	5.1	AS5600L-WL_EK_AB Schematics.....	8
1.2	Ordering Information.....	3	5.2	AS5600L-WL_EK_AB PCB Layout .....	9
<b>2</b>	<b>Board Description .....</b>	<b>4</b>	<b>6</b>	<b>Revision Information .....</b>	<b>10</b>
2.1	Mounting the AS5600L Adapter Board .....	5	<b>7</b>	<b>Legal Information.....</b>	<b>11</b>
<b>3</b>	<b>AS5600L Adapter Board and Pinout .....</b>	<b>6</b>			
<b>4</b>	<b>Operation Case.....</b>	<b>7</b>			
4.1	I <sup>2</sup> C Mode.....	7			

# 1 Introduction

The AS5600L adapter board is a small PCB allowing simple and quick testing or evaluation of the AS5600L magnetic position sensor without the need to build a test fixture or design an own PCB.

## 1.1 Kit Content

Figure 1:  
Kit Content

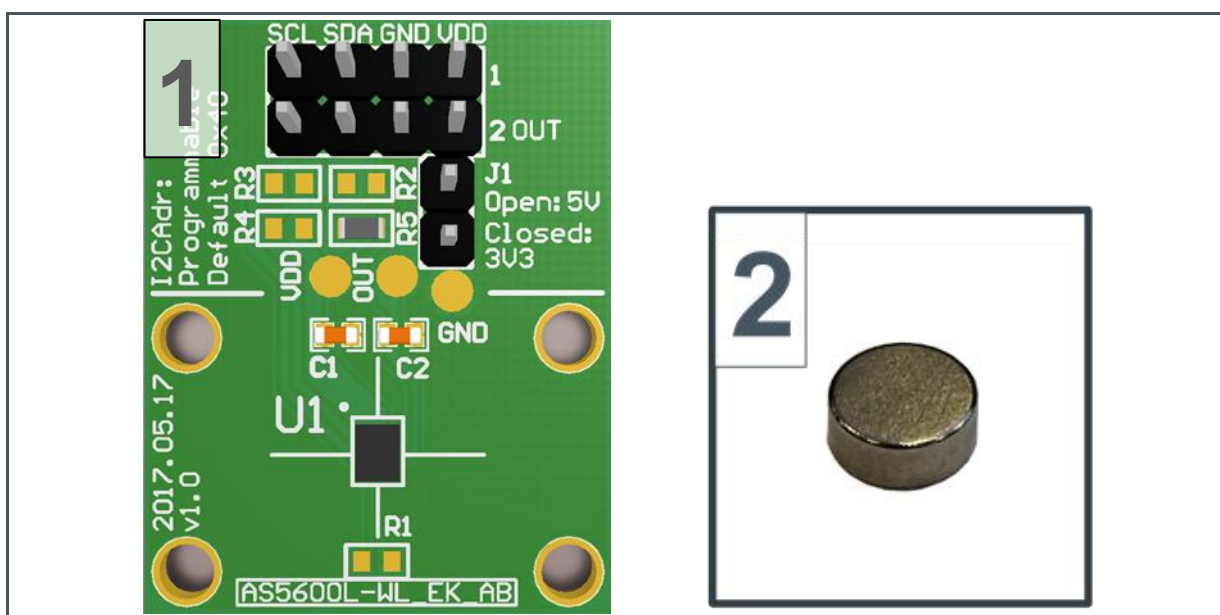

No.	Item	Description
1	AS5600L-WL_EK_AB	Adapter Board
2	AS5000-MD6H-2	Diametric Magnet, D6x2.5 mm, NdFeB, Bomatec AG

## 1.2 Ordering Information

Ordering Code	Description
AS5600L-WL_EK_AB	AS5600L Eval Kit Adapter Board

## 2 Board Description

The PCB can either be connected to an external microcontroller or to the USB I&P Box which is available on our webpage. ([USB I&P Box](#)).

P1 is populated with a 2x4 90 degree pin header and is required for power supply as well as I<sup>2</sup>C (SCL, SDA) and PWM(OUT).

The connector J1 allows you to select between 5 V or 3.3 V operation (Open=5 V/Closed=3.3 V).

The optional resistor R1 (0R – 0603 package) allows you to enable the 3 wire zero programming feature, where you can set the zero and maximum position without using a  $\mu$ C. (for more details refer to AS5600L datasheet)

R2 and R3 are the optional pull-up resistors for SCL and SDA line.

C1 and C2 are decoupling capacitors.

R4 & R5 are used for the direction polarity. Populate R5 for increasing value in clockwise direction, R4 for counterclockwise.

**Figure 2:**  
AS5600L Adapter Board

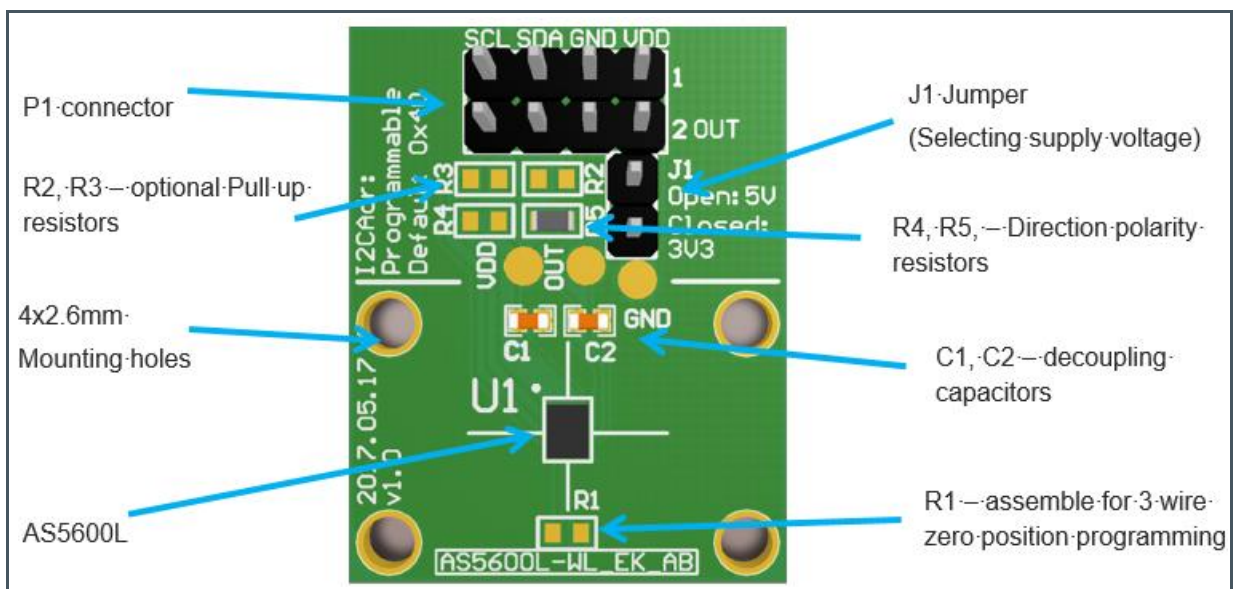

## 2.1 Mounting the AS5600L Adapter Board

Figure 3:  
Mounting and Dimensions

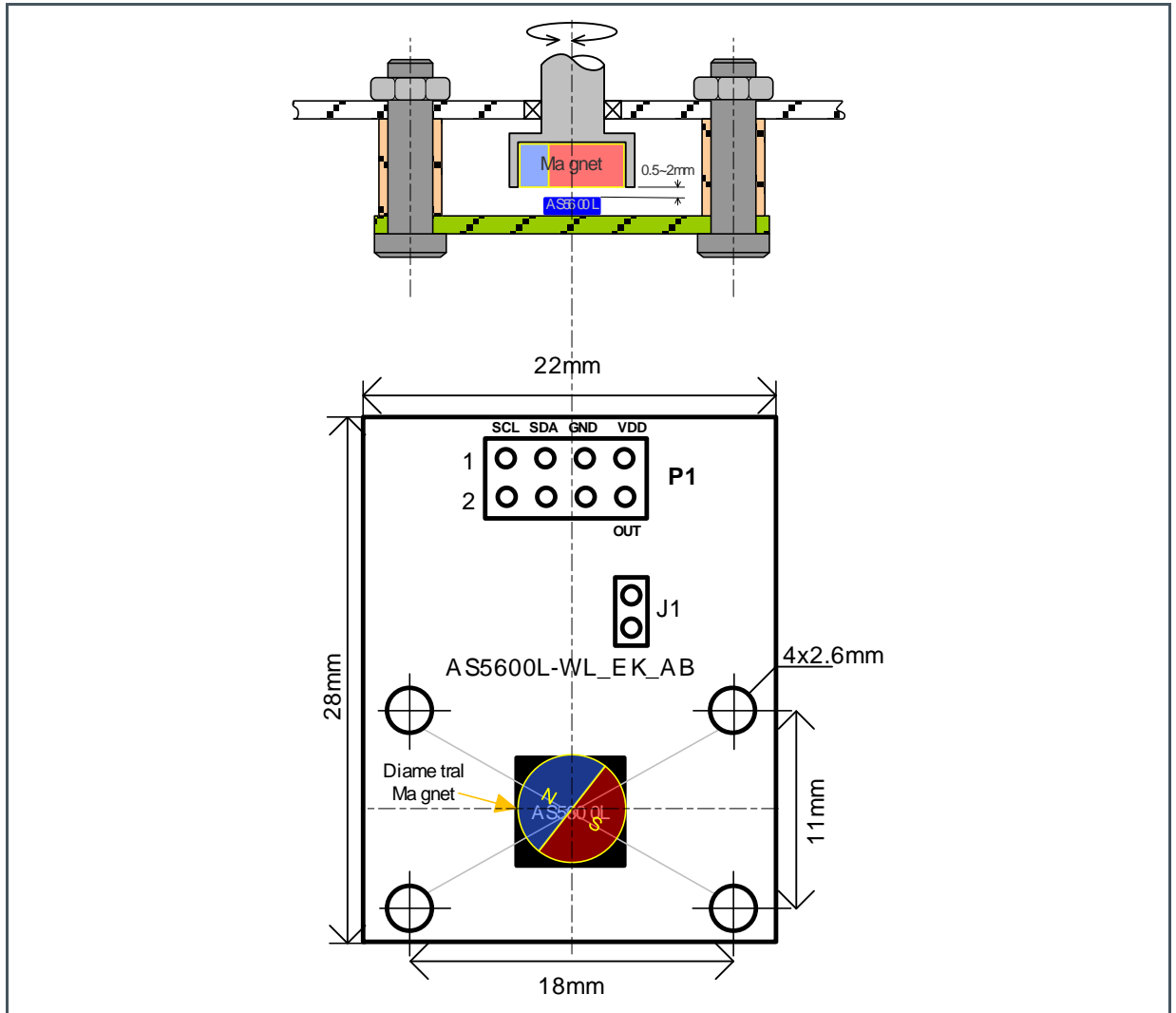

A 6x2.5 mm diametric magnet has to be placed over or under the AS5600L sensor, and should be centered on the middle of the sensors hall array (for hall array center please refer to AS5600L Datsheet). The airgap between the magnet surface and the package should be maintained in the range 0.5 mm to 3 mm. The magnet holder must not be ferromagnetic. Materials as brass, copper, aluminum, stainless steel are the best choices to make this part.

### 3 AS5600L Adapter Board and Pinout

Figure 4:  
AS5600L Adapter Board and Sensor Pinout (WLCSP)

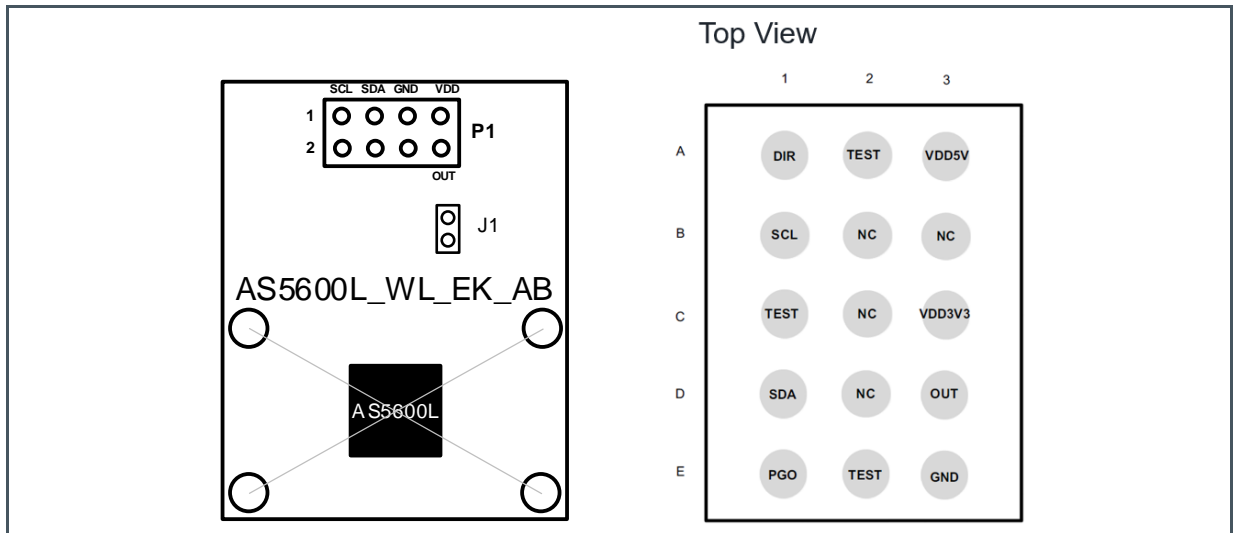

Figure 5:  
Pin Description

Pin#Board	Pin#AS5600L	Symbol Board	Type	Description
P1 - 1	B1	SCL	Digital Input	I <sup>2</sup> C Clock Line
P1 - 2	-	NC	-	Not Connected
P1 - 3	D1	SDA	Digital Input/Output	I <sup>2</sup> C Data Line
P1 - 4	-	NC	-	Not Connected
P1 - 5	E3	GND	Power Supply	Ground
P1 - 6	-	NC	-	Not Connected
P1 - 7	A3/C3	VDD	Power Supply	Positive Voltage Supply (5 V / 3.3 V Mode)
P1 - 8	D3	OUT	Digital Output	PWM Output

## 4 Operation Case

### 4.1 I<sup>2</sup>C Mode

The AS5600L adapter board can be directly connected to an industry standard I<sup>2</sup>C port of a microcontroller. The minimum connection requirements for bidirectional communication between the microcontroller and the AS5600L is VDD, GND, SCL and SDA. The slave address is 0x40.

**Figure 6 :**  
I<sup>2</sup>C Mode

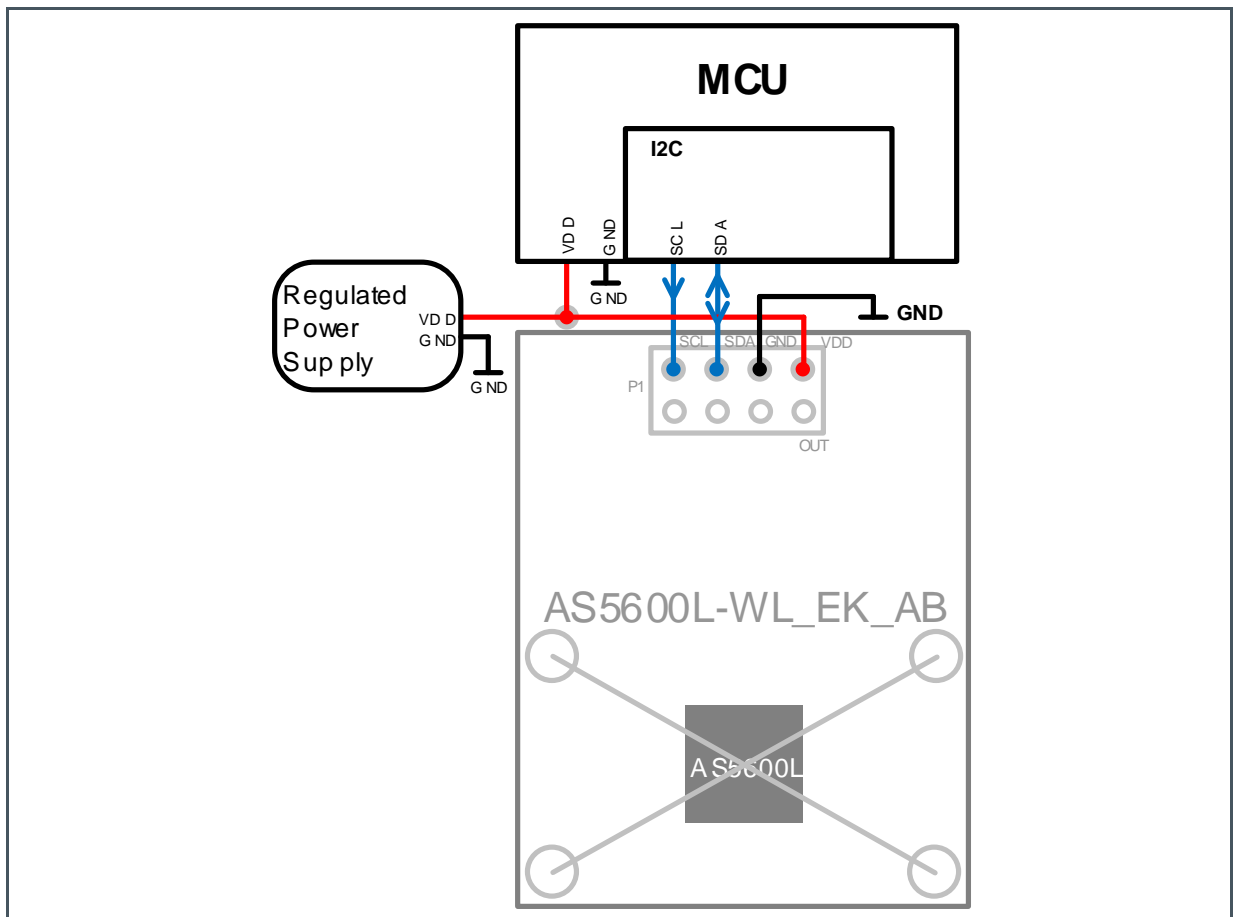



# 5 AS5600L-WL\_EK\_AB Hardware

## 5.1 AS5600L-WL\_EK\_AB Schematics

Figure 7:  
AS5600L-WL\_EK\_AB Schematics

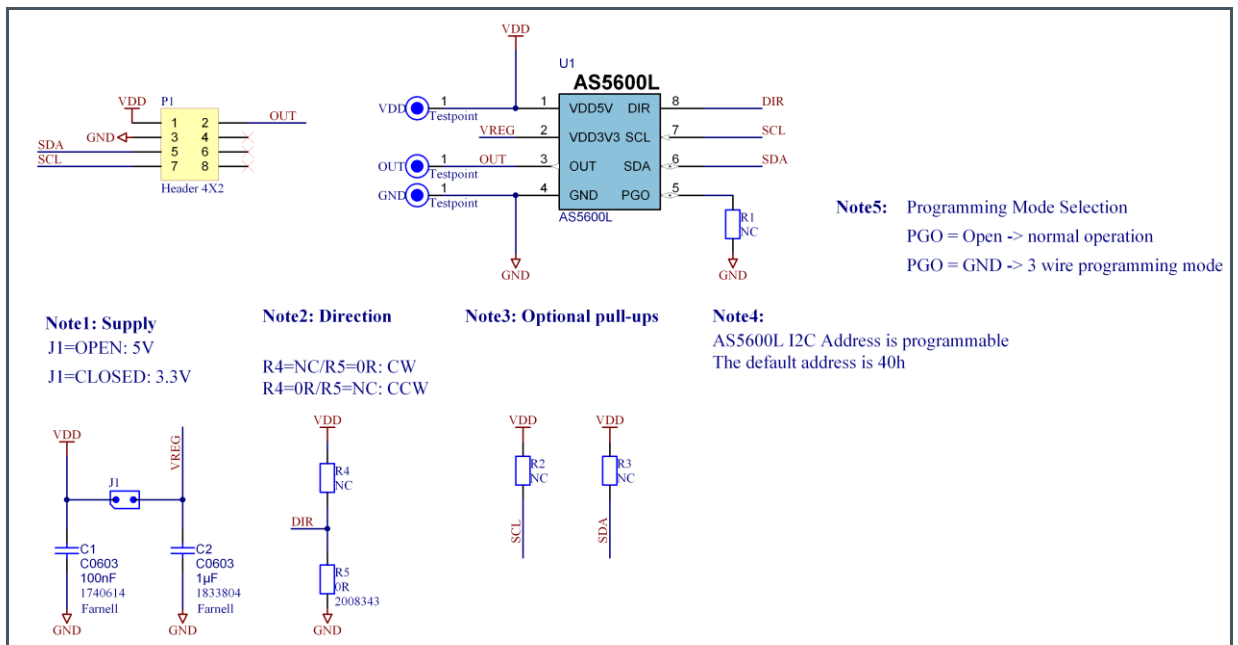

## 5.2 AS5600L-WL\_EK\_AB PCB Layout

Figure 8:  
AS5600L-WL\_EK\_AB PCB Layout

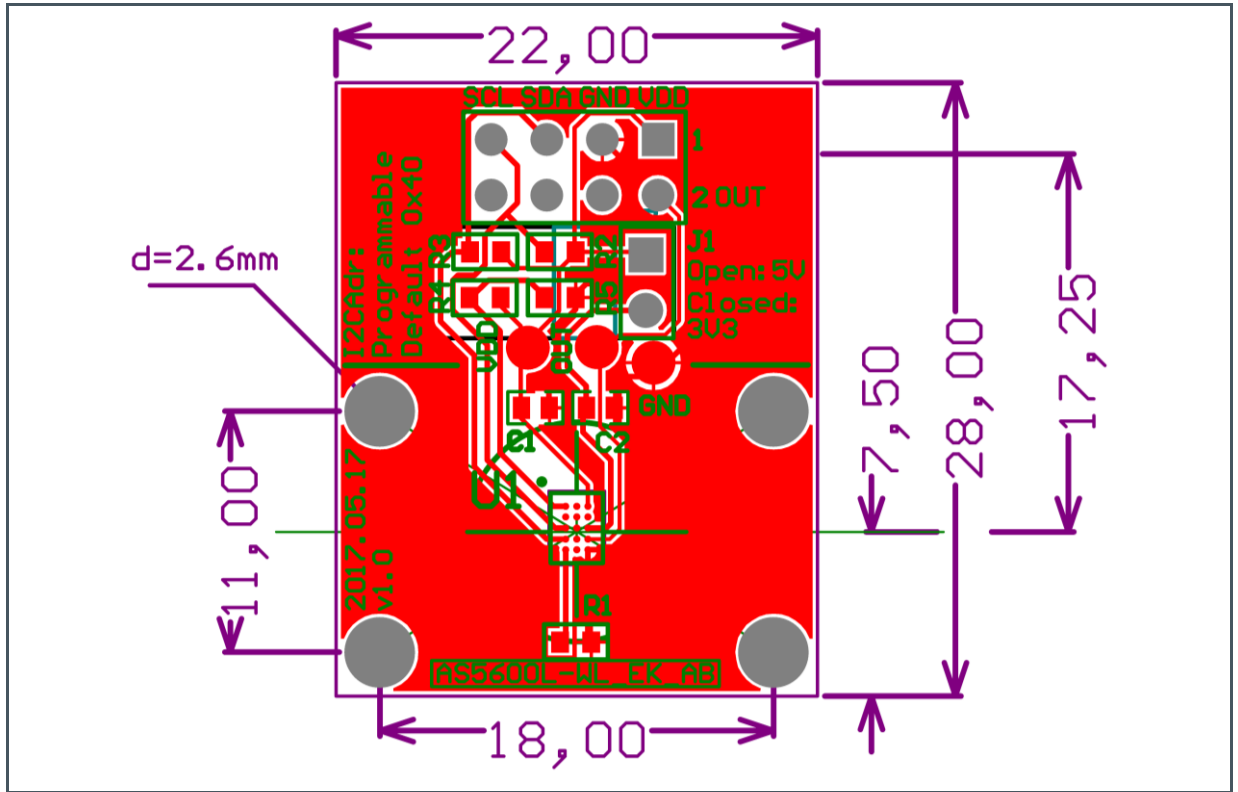

---

## 6 Revision Information

---

Changes from previous version to current revision v2-00	Page
Document converted to latest ams design	
Corrected pinout on figure 3	5
Corrected pinout on figure 4	6
Corrected pinout on figure 5	6

- Page and figure numbers for the previous version may differ from page and figure numbers in the current revision.
- Correction of typographical errors is not explicitly mentioned.