



## User Guide

UG000442

# AS5715 Reference Board

## User Guidance

AS5715\_TS\_EK\_AB

v1-00 • 2019-Dec-17

---

# Content Guide

<b>1</b>	<b>Introduction.....</b>	<b>3</b>	<b>3</b>	<b>Hardware.....</b>	<b>8</b>
1.1	Kit Content.....	3	<b>4</b>	<b>Revision Information.....</b>	<b>10</b>
1.2	Ordering Information .....	4	<b>5</b>	<b>Legal Information .....</b>	<b>11</b>
<b>2</b>	<b>Board Description.....</b>	<b>5</b>			
2.1	First Steps .....	6			
2.2	Pinout .....	6			

# 1 Introduction

The AS5715 Reference Board is a simple PCB which demonstrate the performance of AS5715 in addition with coils (integrated into PCB) and target. It allows easy and quick evaluation of the AS5715 inductive position sensor. The sensor and all necessary external components are already soldered to the PCB. If the 6-pin plug strip is used, it has to be soldered on the board.

## 1.1 Kit Content

Figure 1:  
Kit Content

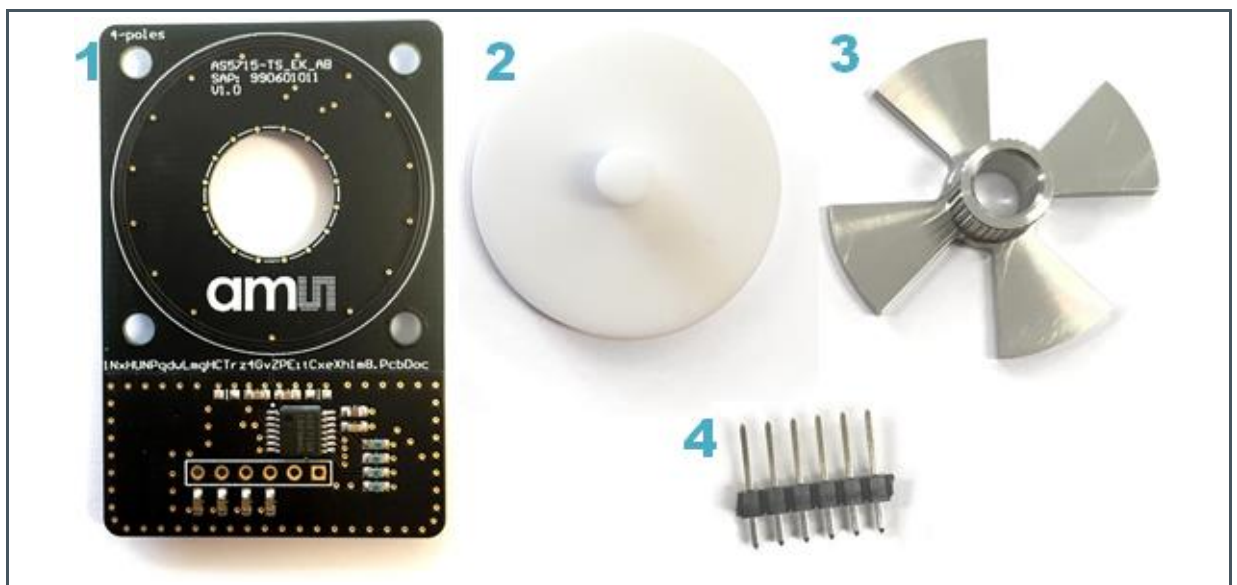

- |  |  |
|--|--|
| <p><b>1</b> Reference Board</p> <p><b>2</b> Spacer</p> | <p><b>3</b> Target</p> <p><b>4</b> Connector</p> |
|--|--|

Figure 2:  
Kit Content List

Position No.	Item	Comments
1	AS5715_TS_EK_AB	Reference Board
2	Spacer	Ceramic plate
3	Target	Target (aluminum)
4	Connector	6-pin plug strip

---

## 1.2 Ordering Information

Ordering Code	Description
AS5715_TS_EK_AB	Reference Board for inductive position sensing

---

## 2 Board Description

The AS5715 is mounted on the PCB and either peripheral components (e.g. capacitors) are located on it. The coil is integrated into the board.

**Figure 3 :**  
**Board Setup**



The connector has to be populated (soldering necessary!) with a 6-pin plug strip and is required for power supply as well as I<sup>2</sup>C and analog output interfaces.



### Information

For setup and detailed communication/programming information, please see the datasheet or application note.

For communication over I<sup>2</sup>C-Interface, connect the PCB to an external microcontroller or to the production programmer of [SD4Y](#), which is available on our webpage. ([SD4Y-PP](#) [Version-not released yet])

## 2.1 First Steps

- Assemble the Reference Board with the ceramic spacer
- Put the target on the spacer
- Connect the Reference Board to supply

Figure 4:  
Easy Setup

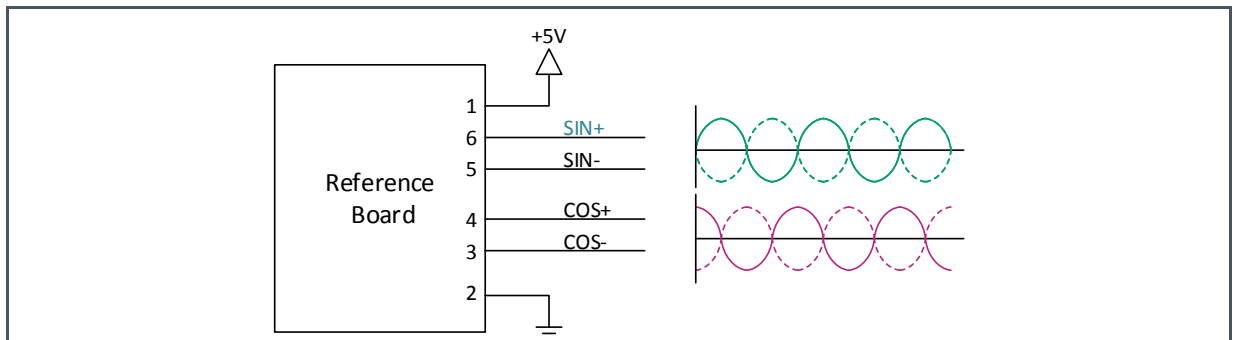

After powering, the sensor is in functional mode and analog sine and cosine signal are available at the connector.

## 2.2 Pinout

Figure 5:  
Pinout On PCB

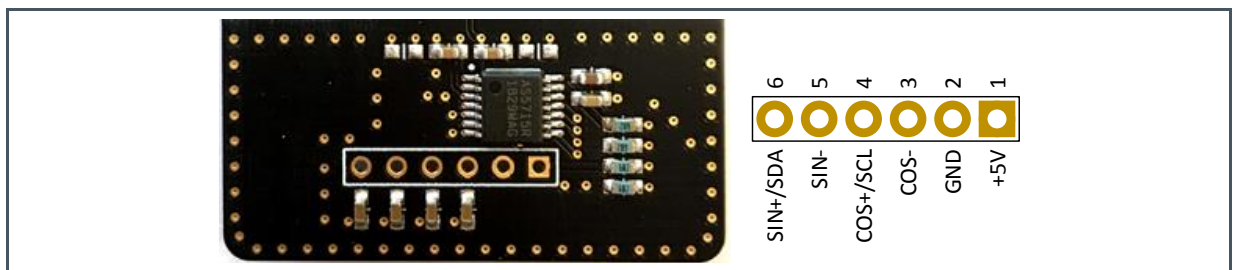

Figure 6:  
Pinout

Pin#	Symbol	Type	Description
1	+5 V	Power Supply	Positive supply voltage
2	GND	Power Supply	Ground

Pin#	Symbol	Type	Description
3	COS-	Analog Output	Analog inverted cosine output signal
4	COS+ / SCL	Analog Output/ digital input	Analog cosine output signal or input clock
5	SIN-	Analog Output	Analog inverted sine output signal
6	SIN+ / SDA	Analog Output/ digital input	Analog sine output signal

### 3 Hardware

Figure 7:  
Schematic

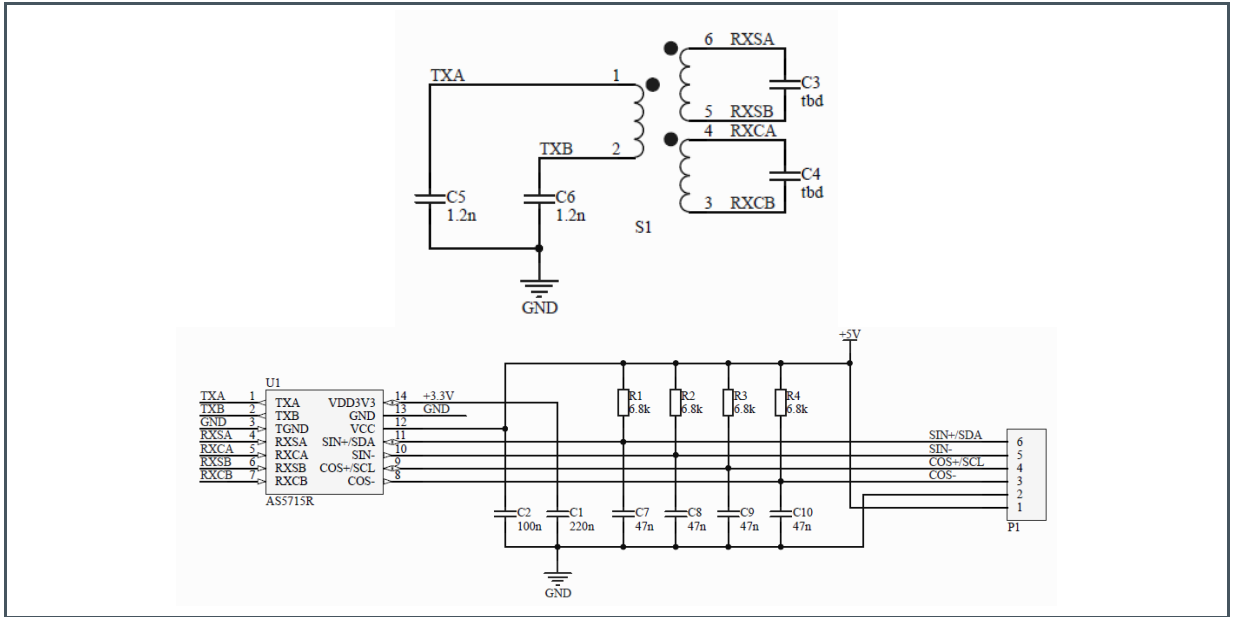
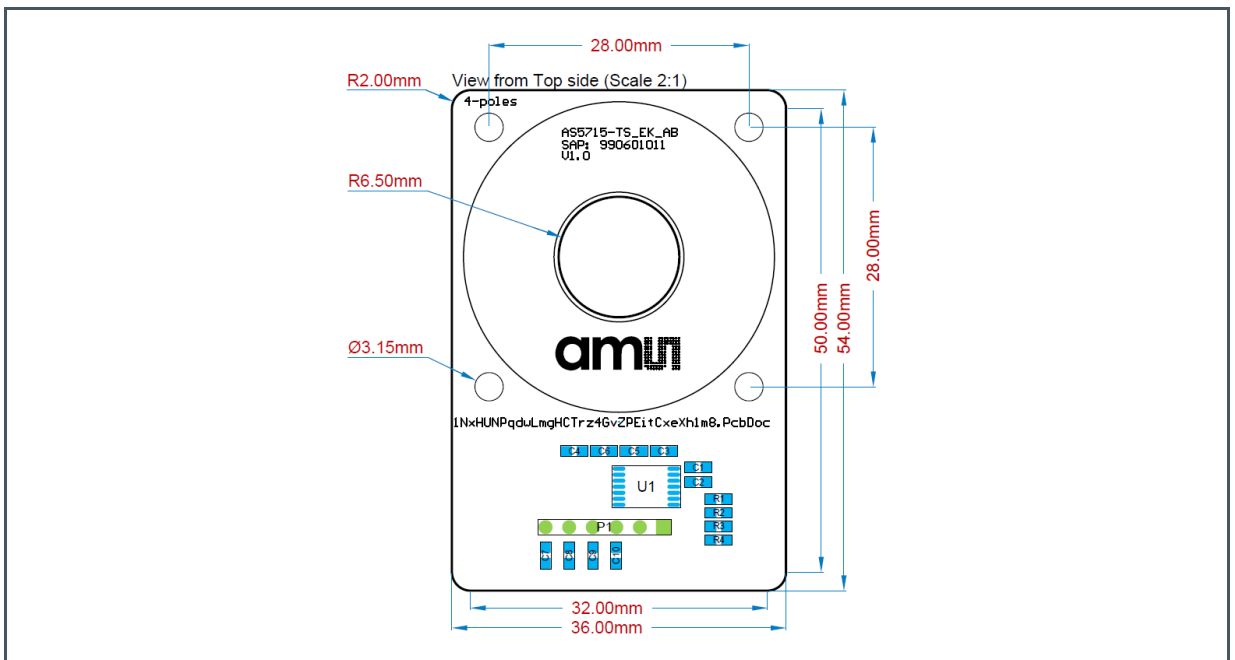

Figure 8:  
Board Components





**Figure 9:**  
**Bill of Materials**

#	Designator	Quantity	Value
1	C1	1	220 nF
2	C2	1	100 nF
3	C3, C4	2	tbd
4	C5, C6	2	1.2 nF
5	C7, C8, C9, C10	4	47 nF
6	P1	1	6-pin Connector
7	R1, R2, R3, R4	4	6.8 kΩ
8	U1	1	AS5715

## 4 Revision Information

Changes from previous version to current revision v1-00	Page
Initial version	

- Page and figure numbers for the previous version may differ from page and figure numbers in the current revision.
- Correction of typographical errors is not explicitly mentioned.