



User Guide

UG000497

AS5x47P

Motor Board

AS5x47P-TS_EK_MB

v1-00 • 2020-Jul-31

Content Guide

1	Introduction.....	3	4	AS5x47P-TS_EK_MB Hardware....	7
1.1	Kit Content.....	3	5	Revision Information.....	9
2	Board Description.....	4	6	Legal Information	10
2.1	Mounting the AS5x47P Motor Board	5			
3	AS5x47P Motor Board Pinout	6			

1 Introduction

The AS5x47P motor board is a simple PCB which is designed to adapt to standard size BLDC or stepper motors. It allows easy and quick evaluation of the AS5x47 magnetic position sensor family.

The sensor and all necessary external components are already soldered to the PCB.

1.1 Kit Content

Figure 1:
Content

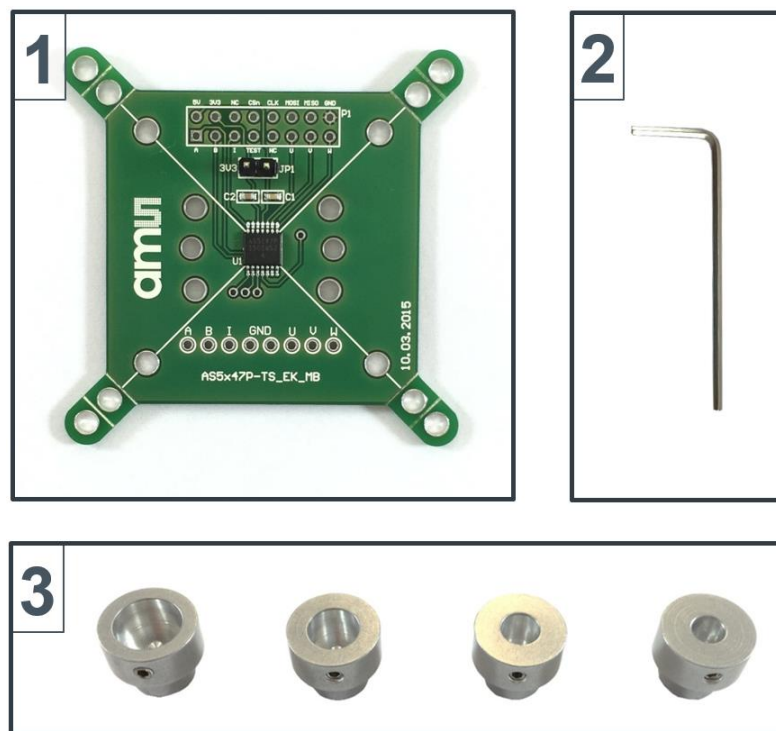

#	Item	Comment
1	AS5x47P-TS_EK_MB	Motor Board
2	Allen key	1.5 mm
3	Magnet holders	Diameters: 10mm, 8mm, 6mm, 5mm

2 Board Description

The PCB can be connected either to an external microcontroller or to the USB I&P Box, which is available on our webpage. ([USB I&P Box](#))

P1 has to be populated with a 2x8 pin header and is required for power supply as well as SPI, ABI, UVW/PWM interfaces.

The connector JP1 allows to select between 5V or 3.3V operation. When JP1 is set only 3.3V operation is possible.

Furthermore, the test pins on the bottom of the PCB give easy access to incremental outputs (ABI and UVW) for probing and measuring with an oscilloscope.

Figure 2:
AS5x47P Motor Board

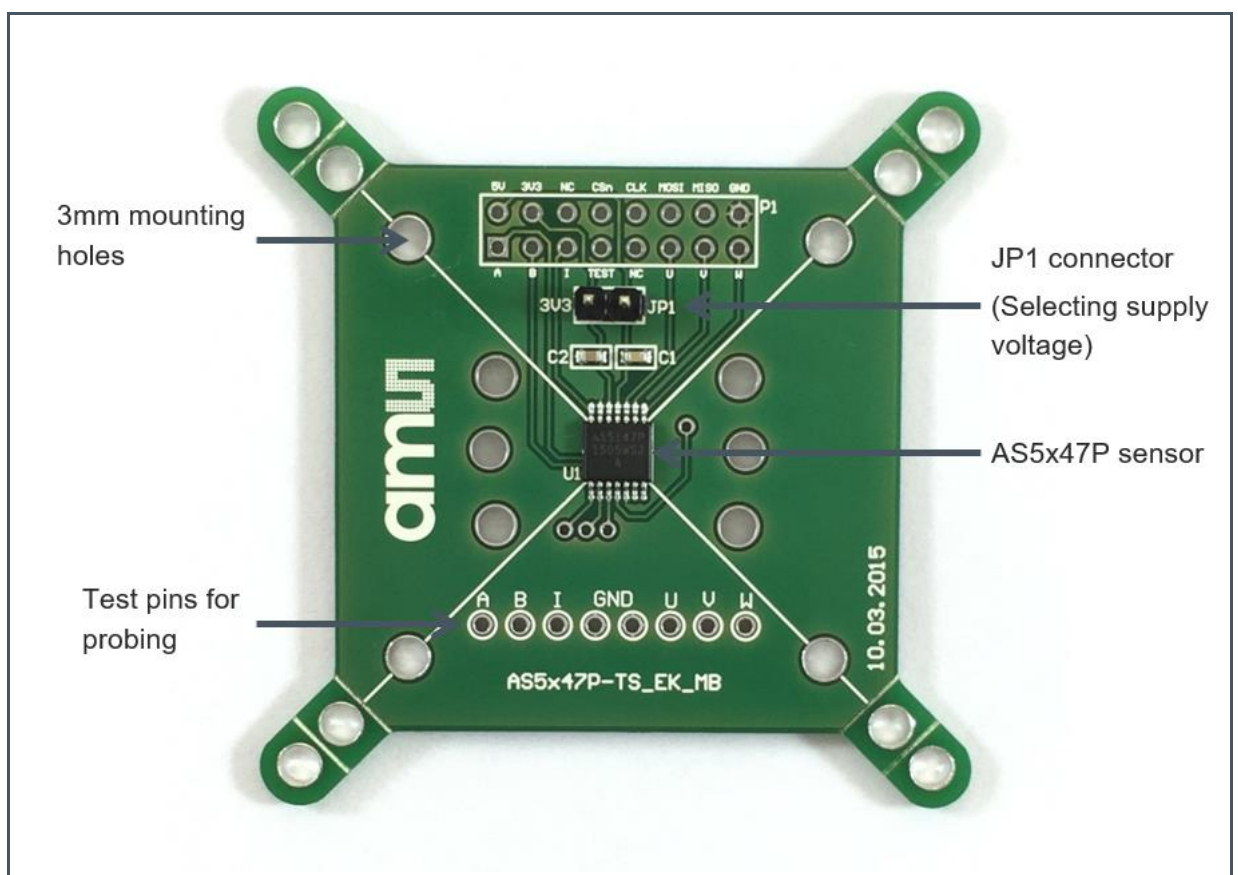

2.1 Mounting the AS5x47P Motor Board

Figure 3:
Mounting On Motor

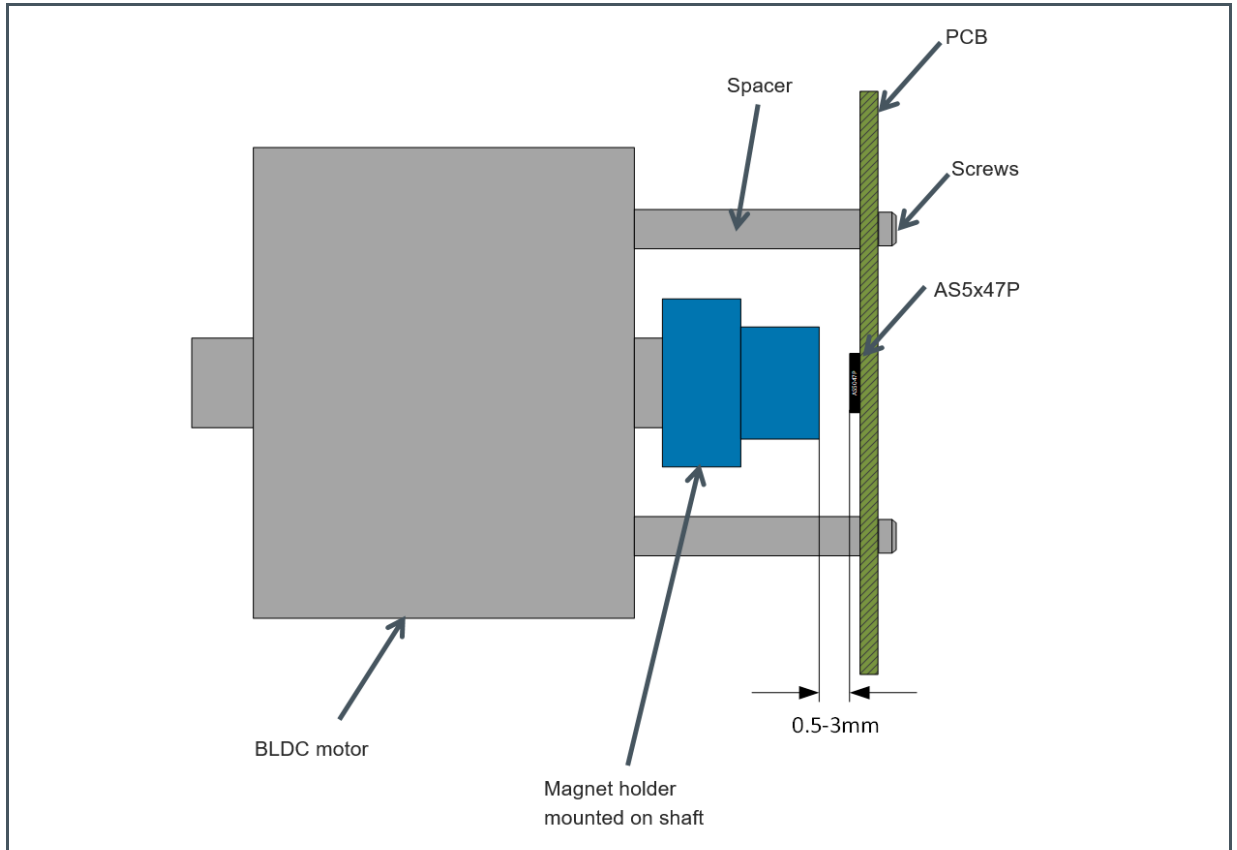

3 AS5x47P Motor Board Pinout

Figure 4:
Pinout

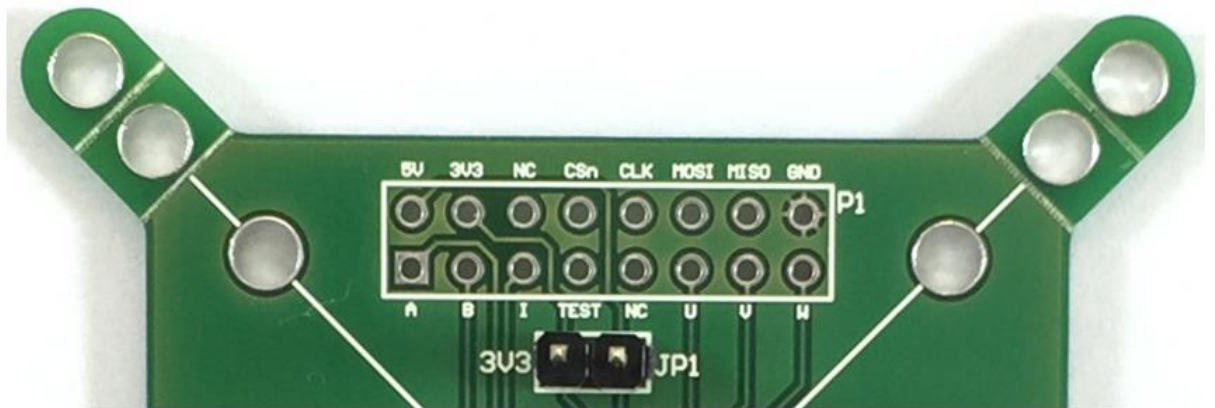

Pin# Board	Symbol Board	Type	Description
P1 - 1	5V	Power supply	Positive supply voltage
P1 - 2	3V3	Power supply	3.3V LDO output
P1 - 3	NC		Not connected
P1 - 4	CSn	Digital input	SPI chip select (active low)
P1 - 5	CLK	Digital input	SPI Clock
P1 - 6	MOSI	Digital input	SPI MOSI
P1 - 7	MISO	Digital output	SPI MISO
P1 - 8	GND	Power supply	Ground
P1 - 9	A	Digital output	Incremental signal A (quadrature)
P1 - 10	B	Digital output	Incremental signal B (quadrature)
P1 - 11	I	Digital output	Incremental signal I (index) or PWM
P1 - 12	TEST		Test pin (connect to ground)
P1 - 13	NC		Not connected
P1 - 14	U	Digital output	Commutation signal U
P1 - 15	V	Digital output	Commutation signal V
P1 - 16	W	Digital output	Commutation signal W or PWM

4 AS5x47P-TS_EK_MB Hardware

Figure 5:
Schematics

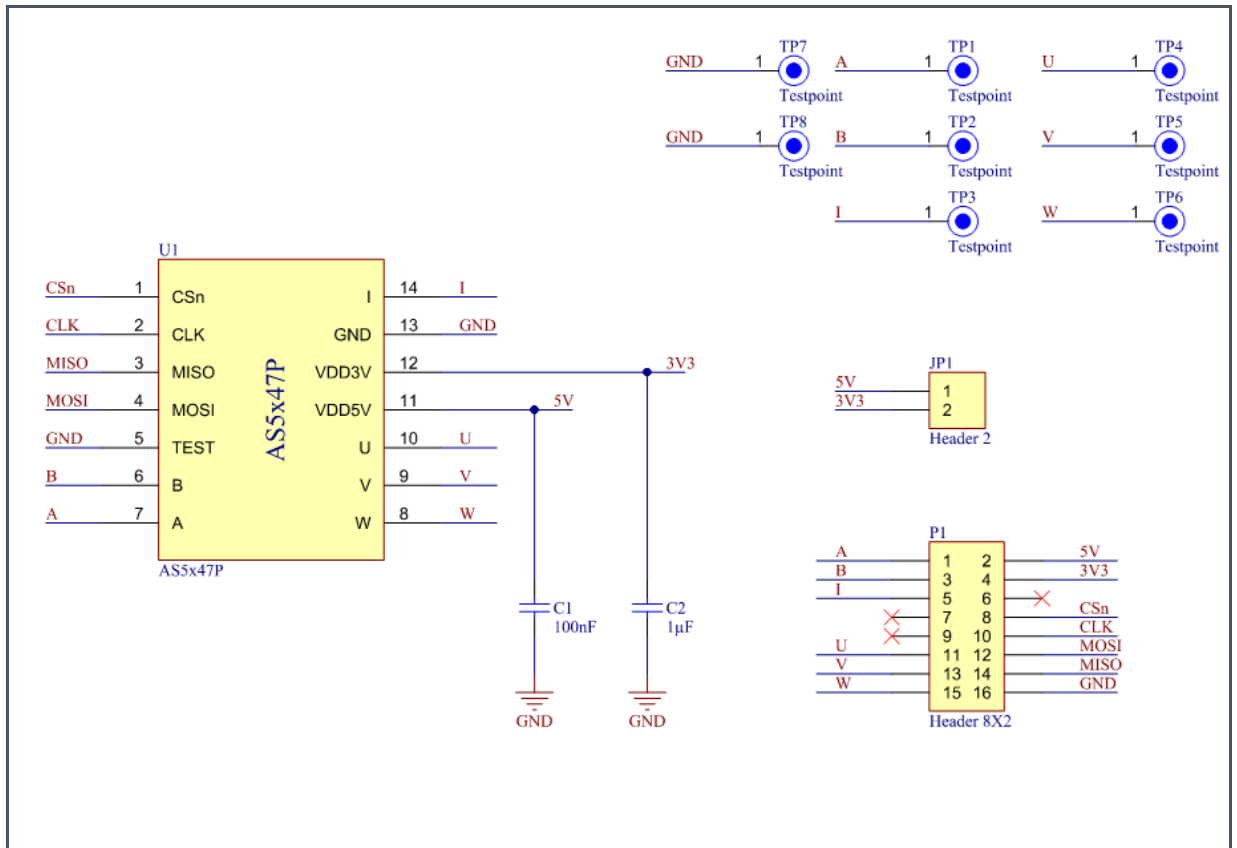
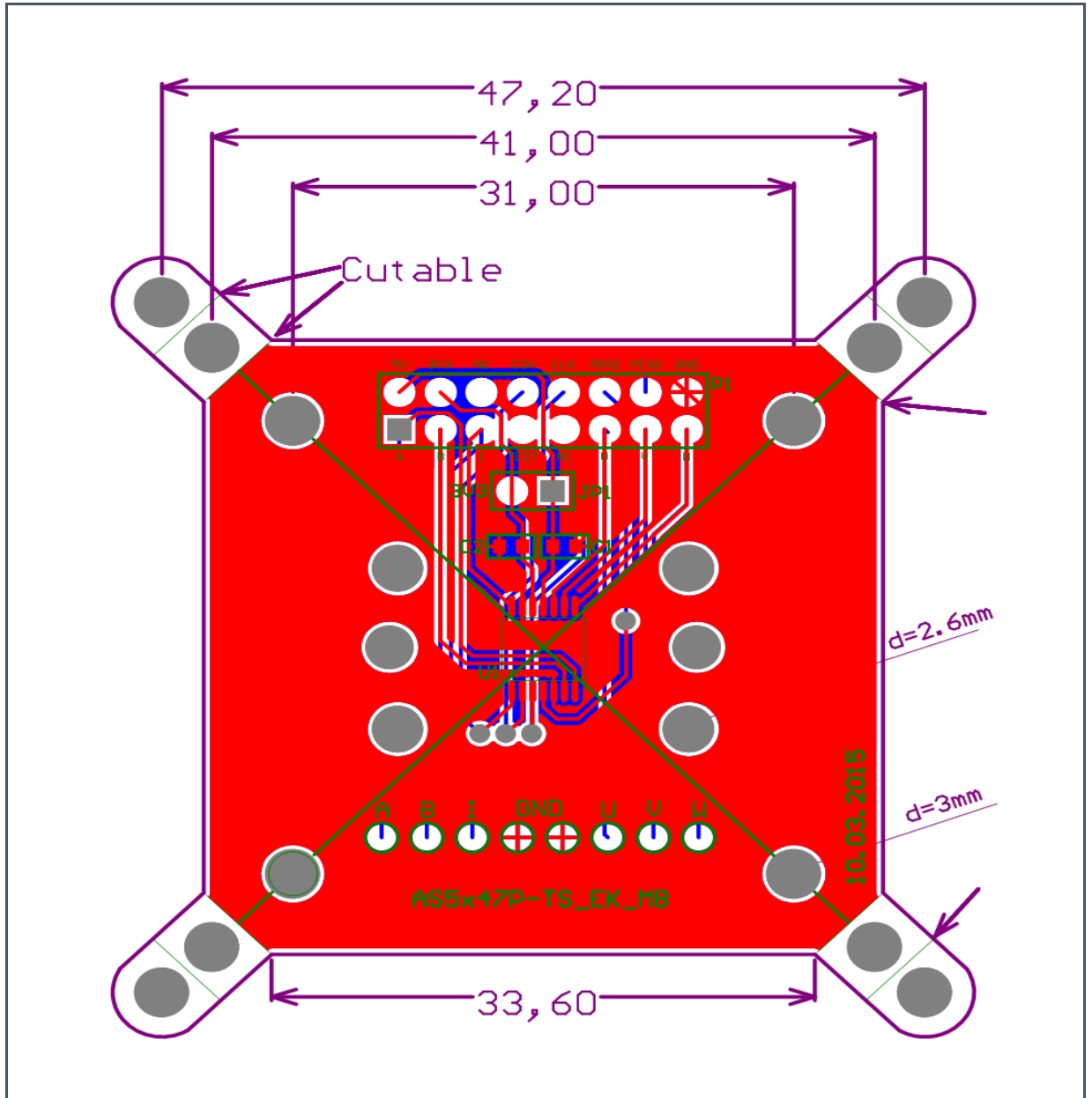

Figure 6:
PCB Layout



5 Revision Information

Changes from previous version to current revision v1-00	Page
Initial Document	

- Page and figure numbers for the previous version may differ from page and figure numbers in the current revision.
- Correction of typographical errors is not explicitly mentioned.