



## User Guide

UG000401

# AS5x47U Adapter Board

## Adapter Board User Manual

AS5047U & AS5147U

v1-00 • 2018-Oct-31

---

# Content Guide

<b>Content Guide</b> .....	<b>2</b>	4.2	One Device SPI Mode, Bidirectional – 4 Wire, 5V Operation .....	8
<b>1 Introduction</b> .....	<b>3</b>	<b>5</b>	<b>AS5x47U-TS_EK_AB Hardware</b> ....	<b>9</b>
1.1 Kit Content.....	3	5.1	Schematics.....	9
1.2 Ordering Information .....	3	5.2	Layout .....	10
<b>2 Board Description</b> .....	<b>4</b>	<b>6</b>	<b>Revision Information</b> .....	<b>11</b>
2.1 Mounting the AS5X47U Adapter Board .....	5	<b>7</b>	<b>Legal Information</b> .....	<b>12</b>
<b>3 Adapter Board and Pinout</b> .....	<b>6</b>			
<b>4 Operation Case</b> .....	<b>7</b>			
4.1 One Device SPI Mode, Bidirectional – 4 Wire, 3V3 Operation.....	7			

# 1 Introduction

The AS5x47U adapter board is a small PCB allowing simple and quick testing or evaluation of the AS5x47U magnetic position sensor without the need to build a test fixture or design an own PCB.

AS5x47U-TS\_EK\_AB can be assembled with an AS5047U or AS5147U sensor.

## 1.1 Kit Content

**Figure 1:**  
Adapter Board

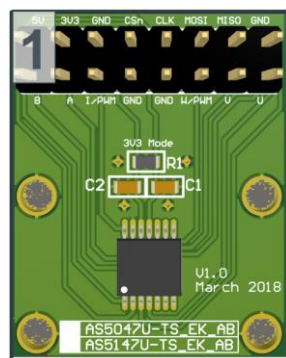

**Figure 2:**  
Diametric Magnet



Pos.	Item	Comment
1	AS5x47U-TS_EK_AB	Adapter board
2	AS5000-MD8H-2	Diametric magnet, D8x2.5mm, NdFeB, Bomatec AG

## 1.2 Ordering Information

Ordering Code	Description
AS5x47U-TS_EK_AB	Adapter board assembled with AS5147U per default Assembly of AS5047U possible (pin compatible)

## 2 Board Description

The PCB can either be connected to an external microcontroller or to the USB I&P Box which is available on our webpage. (USB I&P Box)

P1 has to be populated with a 2x8 pin header and is required for power supply as well as SPI, ABI, UVW/PWM interfaces.

C1 (100 nF) and C2 (1  $\mu$ F) are capacitors to stabilize supply voltage.

R1 is an optional 0 ohm resistor with 0608 package. User can populate to connect 5V and 3V3 pin in case of 3V operation mode. As alternative both pins (5V and 3V3) on pin header P1 can be interconnected for 3V operation mode

**Figure 3 :**  
**AS5x47U Adapter Board**

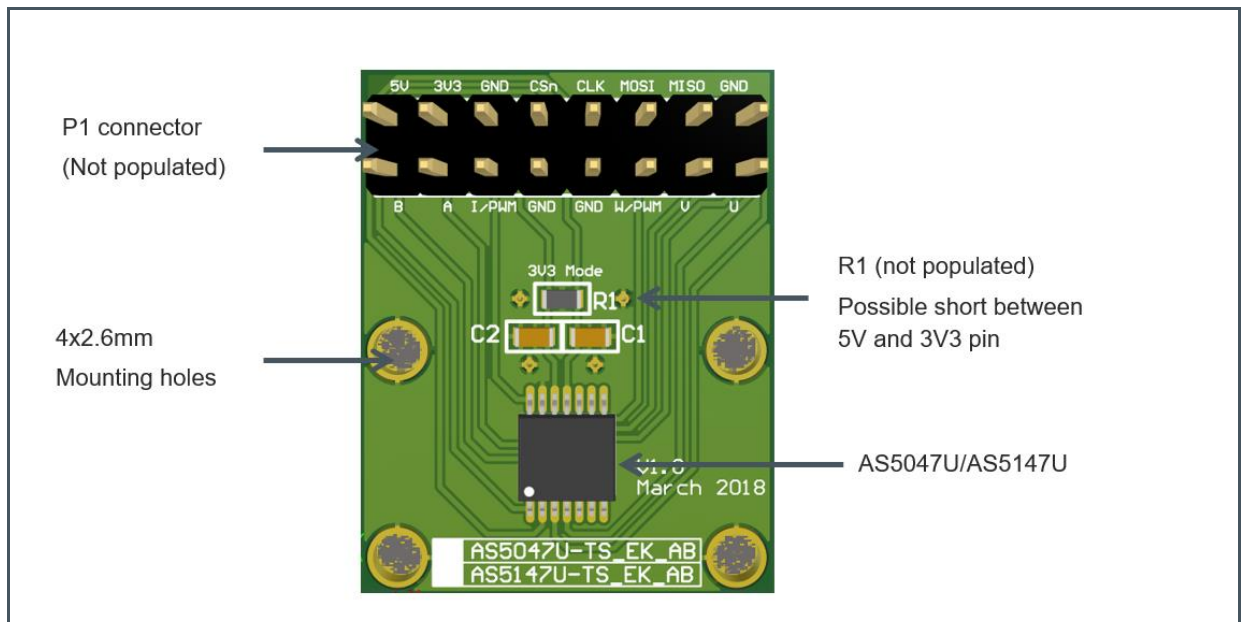

## 2.1 Mounting the AS5X47U Adapter Board

Figure 4 :  
Mounting and Dimensions

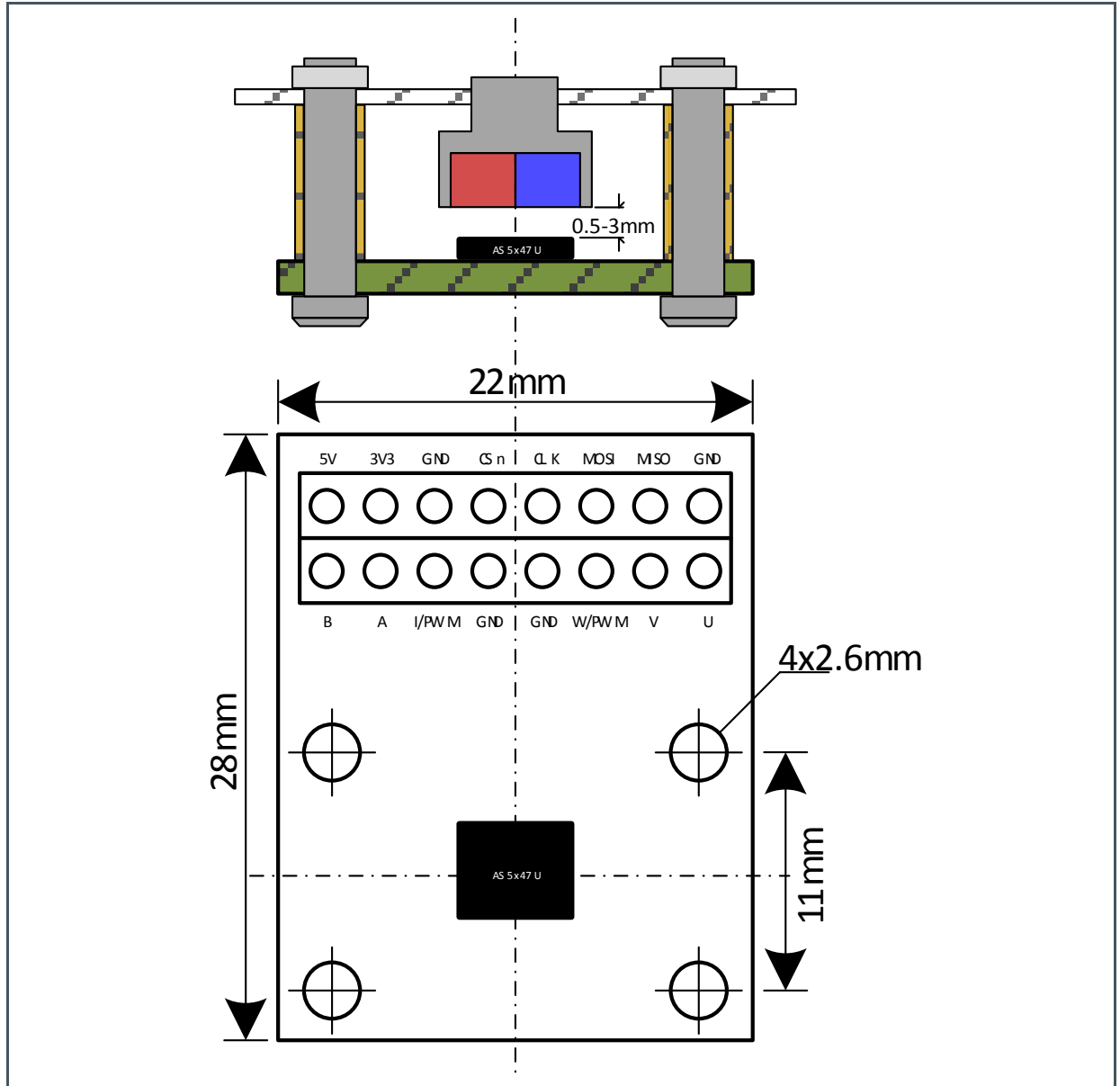

A diametric magnetized magnet must be placed over or under the AS5x47U sensor, and should be centered on the middle of the package with a tolerance of 0.5mm. The air gap between the magnet surface and the package should be maintained in the range 0.5mm to 3mm. The magnet holder must not be ferromagnetic. Materials as brass, copper, aluminum, stainless steel are the best choices to make this part.

### 3 Adapter Board and Pinout

**Figure 5:**  
Adapter Board Pinout

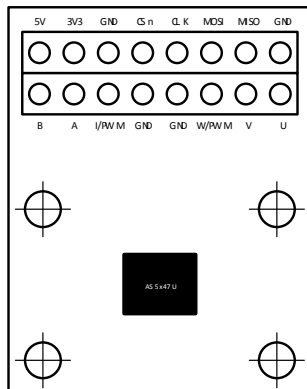

**Figure 6:**  
Sensor Pinout

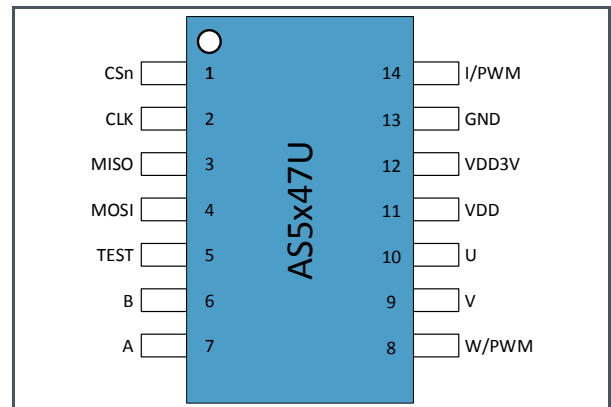

**Figure 7:**  
Pinout Description

Pin# Board	Pin# AS5X47U	Symbol Board	Type	Description
P1 - 1	11	5V	Power supply	Positive supply voltage
P1 - 2	12	3V3	Power supply	3.3V LDO output
P1 - 3	13	GND	Power supply	Ground
P1 - 4	1	CSn	Digital input	SPI chip select (active low)
P1 - 5	2	CLK	Digital input	SPI clock
P1 - 6	4	MOSI	Digital input	SPI MOSI
P1 - 7	3	MISO	Digital output	SPI MISO
P1 - 8	13	GND	Power supply	Ground
P1 - 9	6	B	Digital output	Incremental signal B (quadrature)
P1 - 10	7	A	Digital output	Incremental signal A (quadrature)
P1 - 11	14	I/PWM	Digital output	Incremental signal I (index) or PWM
P1 - 12	13	GND	Power supply	Ground
P1 - 13	13	GND	Power supply	Ground
P1 - 14	8	W/PWM	Digital output	Commutation signal W or PWM
P1 - 15	9	V	Digital output	Commutation signal V
P1 - 16	10	U	Digital output	Commutation signal U

## 4 Operation Case

### 4.1 One Device SPI Mode, Bidirectional – 4 Wire, 3V3 Operation

To be able to write and read data from AS5x47U sensor, connect all 4 SPI lines to a SPI master device.

#### 4.1.1 3V3 Operation

Supply 5V pin and 3V3 with 3.3V.

As an alternative, the user can assemble R1 with a 0 ohm bridge to short the 5V and VDD3V pin. In this case, only one of the supply pins need to be supplied with 3.3 V.

Digital output operates at 3.3V level.

**Figure 8 :**  
**One Device SPI Mode, Bidirectional – 4 Wire, 3V3 Operation**

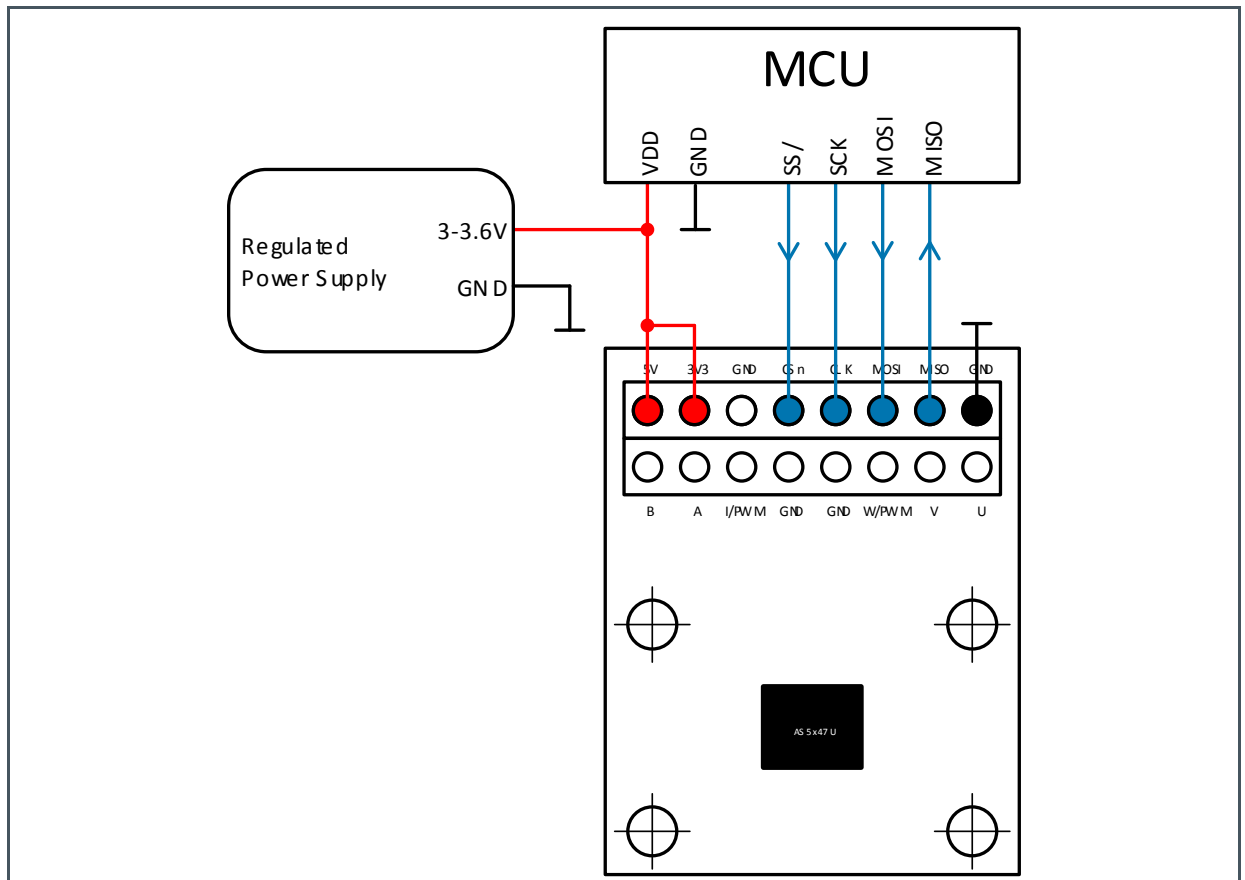

## 4.2 One Device SPI Mode, Bidirectional – 4 Wire, 5V Operation

To be able to write and read data from AS5x47U sensor, connect all 4 SPI lines to a SPI master device.

### 4.2.1 5V Operation

Supply 5V pin with 5V.

Leave 3V3 pin open. In this case, the 3V3 pin is the LDO output. No load allowed.

R1 must not be assembled!

**Figure 9 :**  
**One Device SPI Mode, Bidirectional – 4 Wire, 5V Operation**

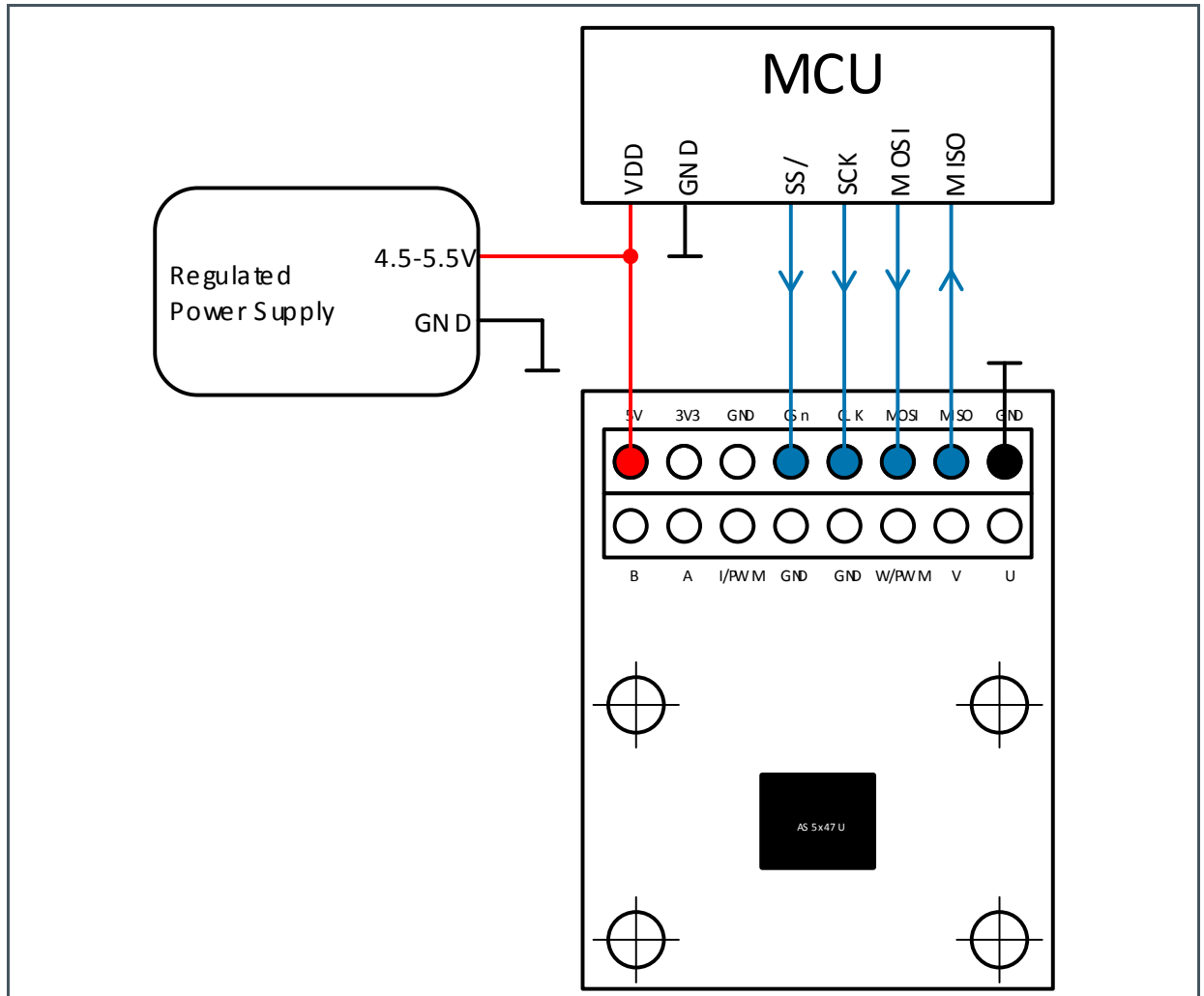



# 5 AS5x47U-TS\_EK\_AB Hardware

## 5.1 Schematics

Figure 10 :  
Schematic

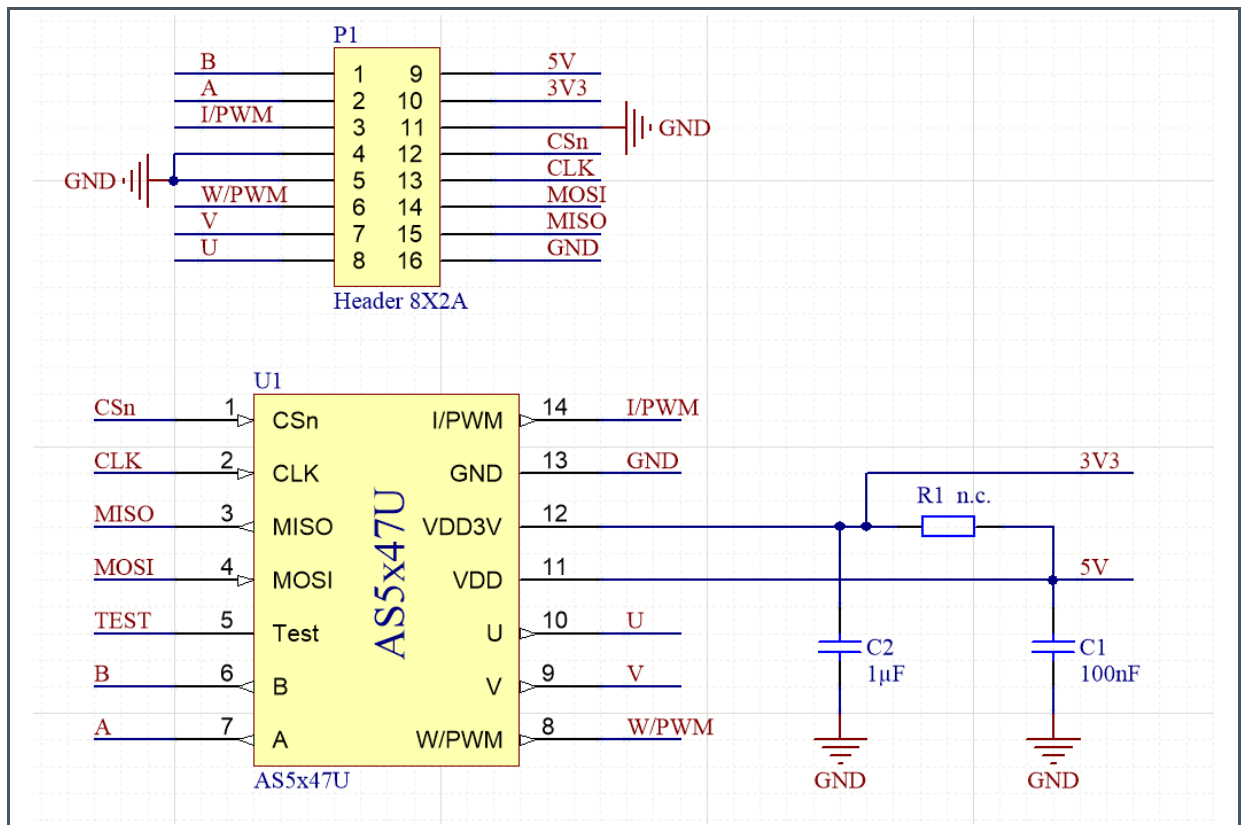

## 5.2 Layout

The adapter board is based on two copper layers. All signal and supply lines are placed on Top-Layer, Bottom-Layer is used as ground plane.

The four mounting holes are connected to GND as well.

Figure 11 :  
PCB Layout

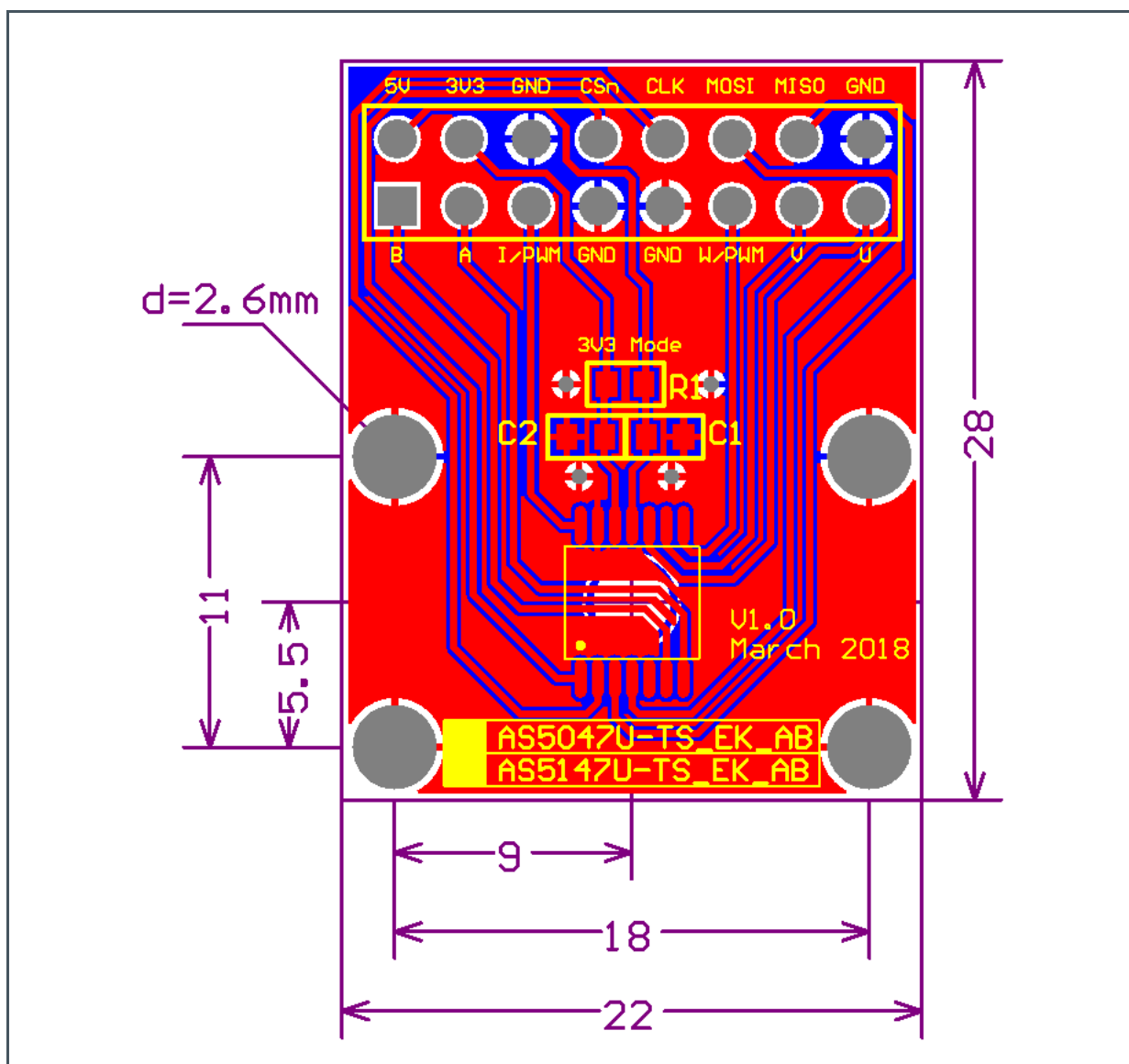

---

## 6 Revision Information

---

Changes from previous version to current revision v1-00	Page
---	------

Initial Version

---

- Page and figure numbers for the previous version may differ from page and figure numbers in the current revision.
- Correction of typographical errors is not explicitly mentioned.