

AS6040-QF_DK

Development Kit User Guide

AS6040-QF_DK User Guide

Revision: 5

Release Date: 2023-05-02

Document Status: Production

Content Guide

Content Guide	2
1 Introduction	3
1.1 Ordering Codes	3
2 Quick Start Guide	4
3 Hardware Description	5
3.1 Introduction	5
3.2 Series Load Resistors.....	5
3.3 Filter for PGA	6
3.4 Communication Interface	6
4 Measurements in Practice	7
5 Schematics, Layers & BOM	8
6 RoHS Compliance & SciSense Green Statement	11
7 Copyrights & Disclaimer	11
8 Revision information	12

1 Introduction

The AS6040-DK development kit allows customers a quick and intuitive approach to using the AS6040 UFC in ultrasonic flow meter applications.

The kit includes three elements:

AS6040-QF_DK_RB reference board V2.0, based on AS6040-BQFM in QFN48 package

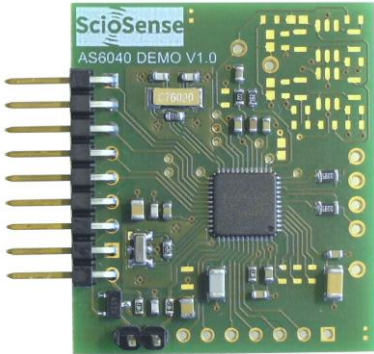

PicoProg Lite with USB-C – USB cable

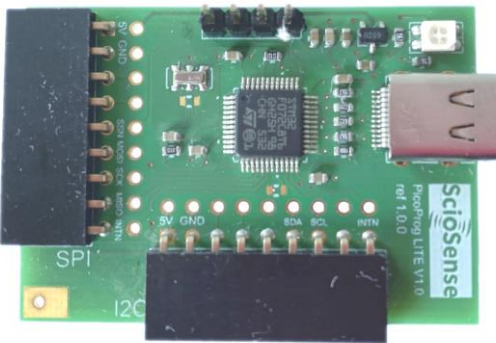

Figure 1: Functional Blocks

Please download the software for the kit from <https://downloads.sciosense.com/AS6040> and look for the latest revision of UfcEvaluationSoftware....zip

1.1 Ordering Codes

Table 1: Pin description

Ordering code	Part Number	Description
AS6040-QF_DK V1.0	221010003	AS6040 Demo kit including PICOPROG and cables
AS6040-QF_DK_RB V2.0	221010002	AS6040 reference board

2 Quick Start Guide

This section describes how to quickly set up the AS6040 development kit, to establish basic operation and to make first measurements.

It is crucial to install the software before connecting the evaluation kit to your computer. The software can be downloaded here:

<https://downloads.sciosense.com/AS6040>

- Unzip the package to the desired directory,
- Connect the PicoProg Lite to the computer and the AS6040 board to the SPI connector on the PicoProg Lite.
- Connect your spool piece to US_UP and US_DOWN. US_UP fires upstream, means versus flow. US_DOWN fires downstream, with the flow.
- Open “UFCEvaluationSoftware.exe”

The following screen will appear:

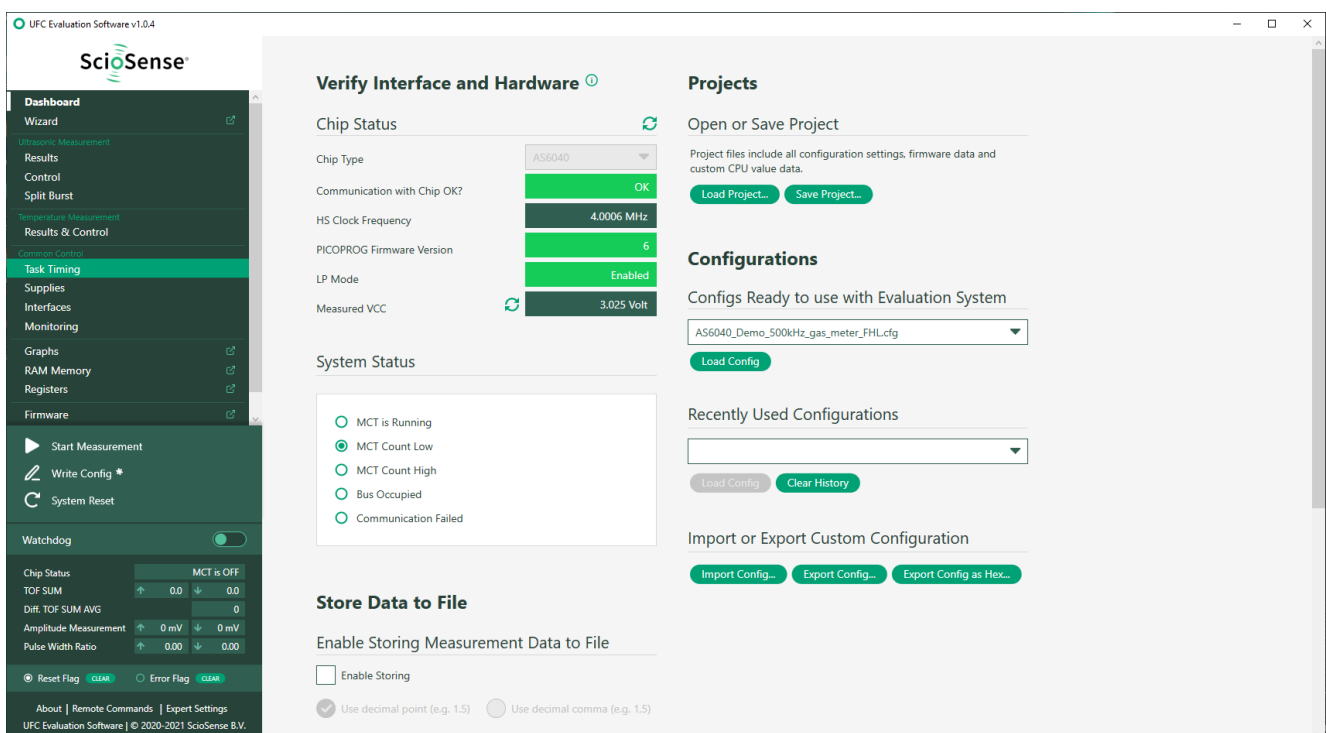

Figure 2: Opening page

- Verify that the right device is selected.
- Select one of the available projects or configuration files, press “Load Project” or “Load Config” and then on the left press “Write Config”.
- Press “Start Measurement” to begin measuring.

3 Hardware Description

3.1 Introduction

The AS6040-QF_DK_RB board, shown in figure 3, is a front-end mainly for gas meters but also water meters. The transducers and temperature sensors are directly connected to this board. It comes with a 32.768 kHz quartz (X2) and a 8 MHz ceramic oscillator (X1).

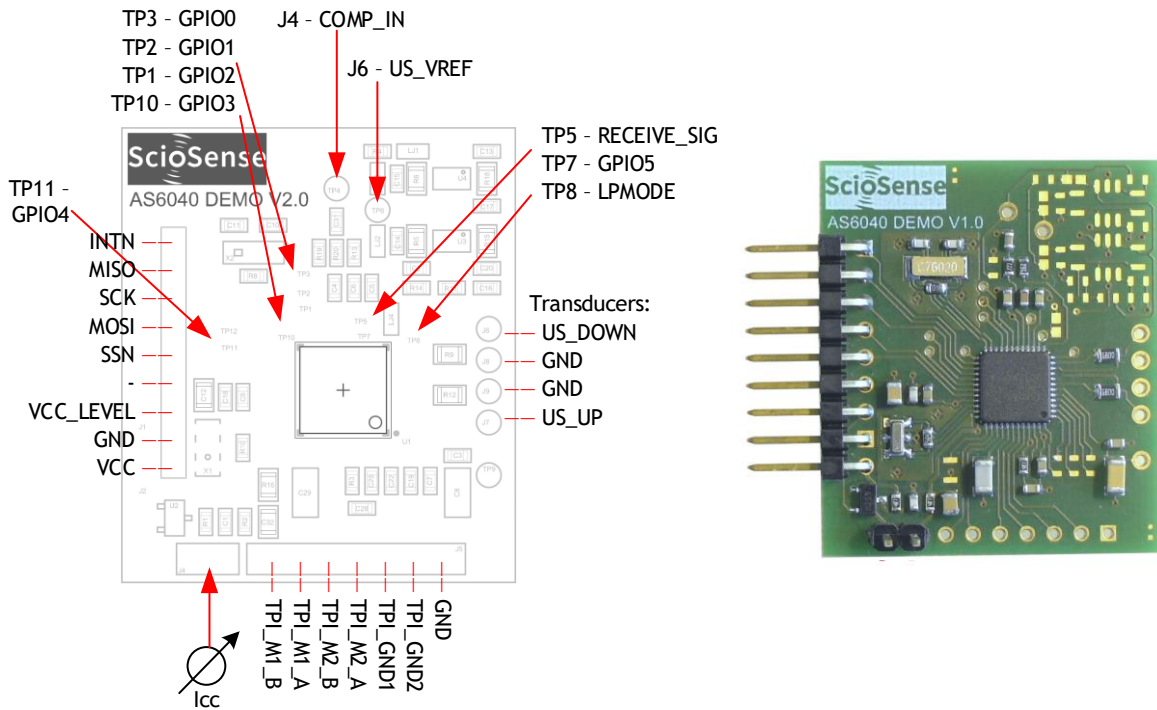

Figure 3: AS6040-QF_DK_RB

3.2 Series Load Resistors

The series load resistors, sometimes also called matching resistors, are assembled by default with 680 Ohm. In case the impedance of the transducers differs a lot those can be replaced.

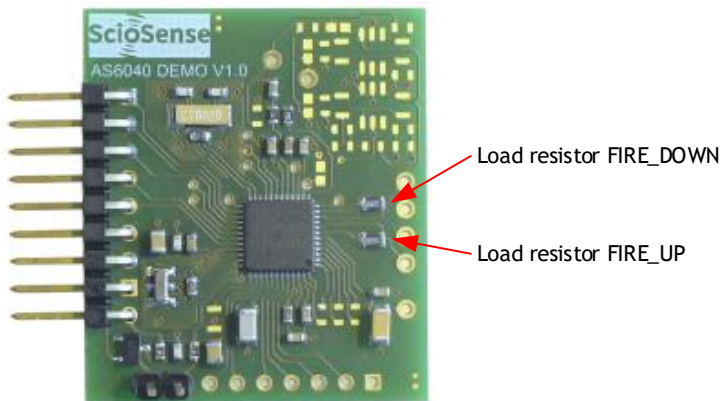

Figure 4: Series load or matching resistors

In application for water with typical frequencies of 1 or 2 MHz the series resistors might better be lower, like 330 Ohm. From experience, the matching does not need to be precise but a rough fit.

3.3 Filter for PGA

In applications with high gain ($> 20V/V$, like in gas meters) the PGA noise may be reduced by an external filter. The filter is configured by setting `TI_PGA_CON_MODE = 2` in the evaluation software. This controls the internal switch to the pad `INVERT_IN`. The filter has to be connected between the `INVERT_IN` and `COMP_IN` pins.

Note: by default, no PGA is assembled on the evaluation board.

The choices for the external resistors and capacitor depend on the fire frequency for the ultrasonic transducer. For gas meters we recommend the following recommended values:

$R_i = 5.6\text{ k}\Omega$ (R13), $C = 10\text{ nF}$ (C31), $R_o = 2.2\text{ k}\Omega$ (R20)

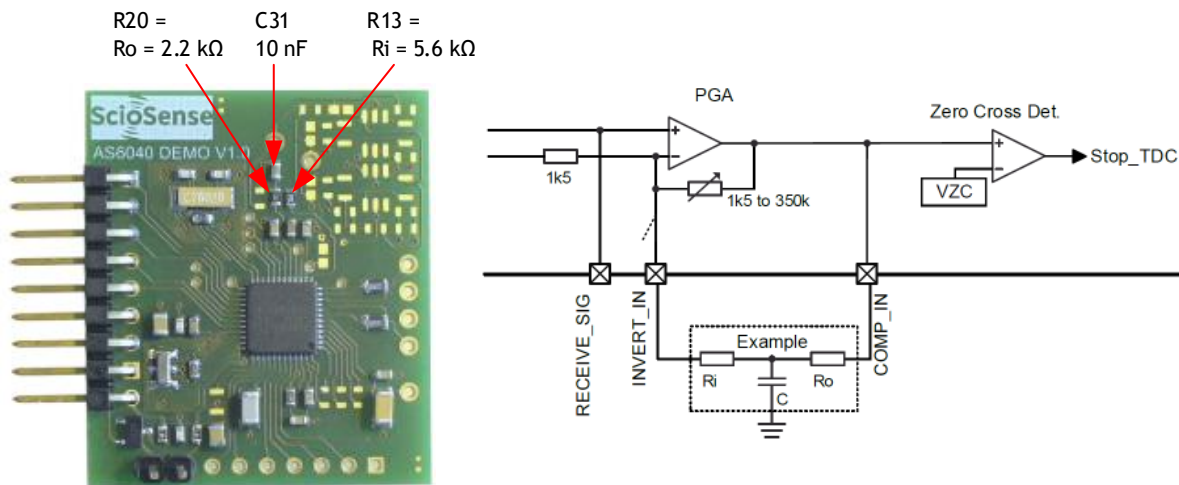

Figure 5: AS6040-QF_DK_RB

The T-filter only becomes effective with high amplification. It then reduces the gain and noise of the PGA at low frequencies. From `PGA_TRIM ≥ 7` on the filter reduces the standard deviation of TOF values. But it also overrides the auto-zero function, and therefore the auto-zero should be disabled when a filter is used, `TI_PGA_AZ_DIS = 1`.

3.4 Communication Interface

The PICOPROG device is a USB-to-SPI converter box that interfaces all UFC evaluation systems. The PICOPROG is registered by the operating system initially as “PICOPROG v2.0 unprogrammed” (for both PICOPROG V2.0 and V3.0). As soon as the UFC evaluation software starts, a special firmware is written into the PICOPROG to handle the SPI communication with the AS6040-QF_DK_RB board. The PICOPROG is now listed as “UNIPRO” in the device manager.

The flat connector connecting the PICOPROG and the AS6040-QF_DK_RB includes the power lines and the SPI communication lines. `VCC_LEVEL` is the voltage feedback for the PICOPROG level shifters.

4 Measurements in Practice

We propose to start with one of the example configurations. The most important parameters to review and set are:

- Fire pulse frequency (typically 100kHz, 200kHz or 500kHz)
- Number of fire pulses (20 is a good start)
- Number of TOF hits (10 is a good start)
- Noise mask Window should be =1. Then directly after the fire burst, with about 10µs delay, the chip switches to receive. Typically you see a short oscillation due to the switching between the send and receive transducer.
- Charge pump voltage and PGA gain of receiving amplitude (to get a receive amplitude of 200 to 400mV)

In general, we recommend to have a look at the receive signal by means of an oscilloscope. This clearly helps to find the right settings.

If the signal is measured at the PGA output, at test pin J4 (pin 17, COMP_IN) then there is no influence of the probe to the measured time values. In Figure 3 this point is marked. Another probe should be connected to US_UP for the trigger signal. When looking at minimum noise then this probe of course needs to be removed.

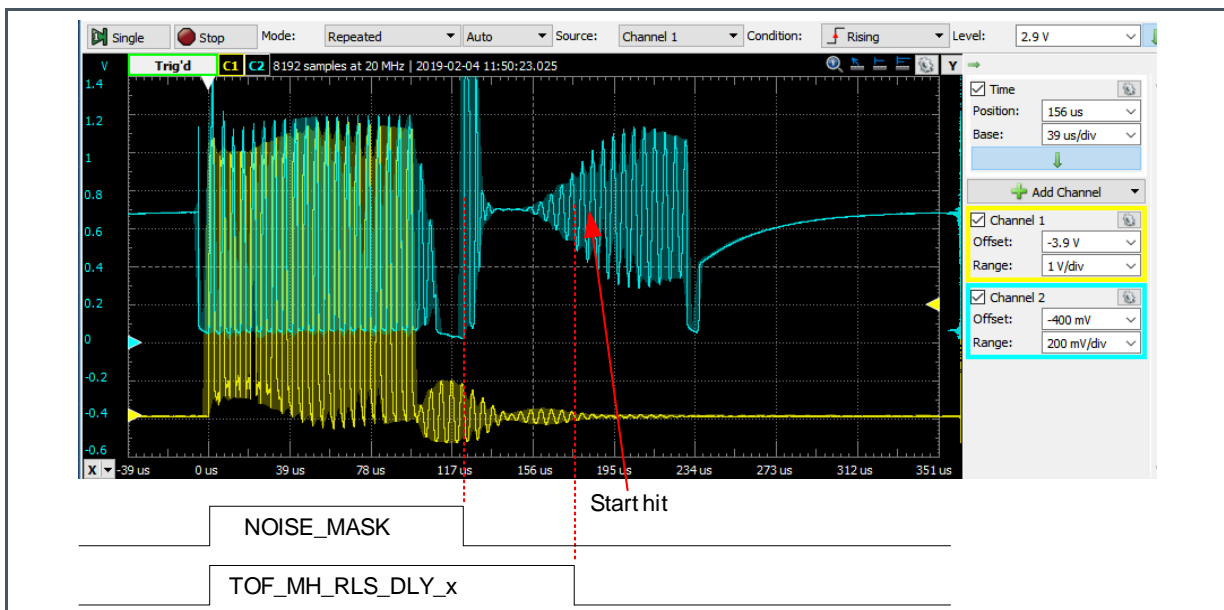

Figure 6: Typical send and receive signals

When working with real gas there might be the need for an external amplification with higher gain than offered by the internal PGA. In this case, please refer to [application note SC-000942-AN](#), “AS6040 with external amplifier” for details.

5 Schematics, Layers & BOM

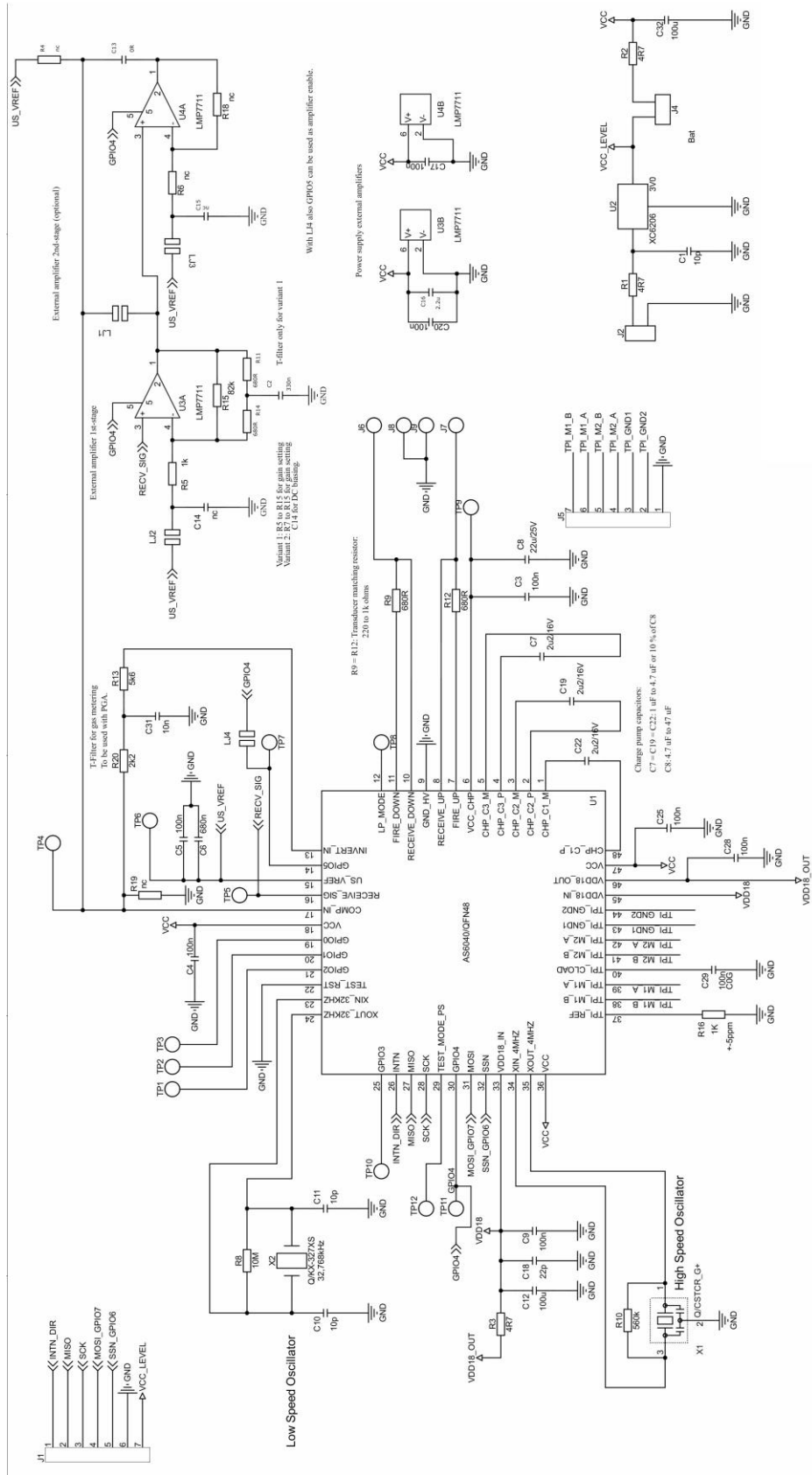

Figure 7: AS6040-QF_DK_RB schematics

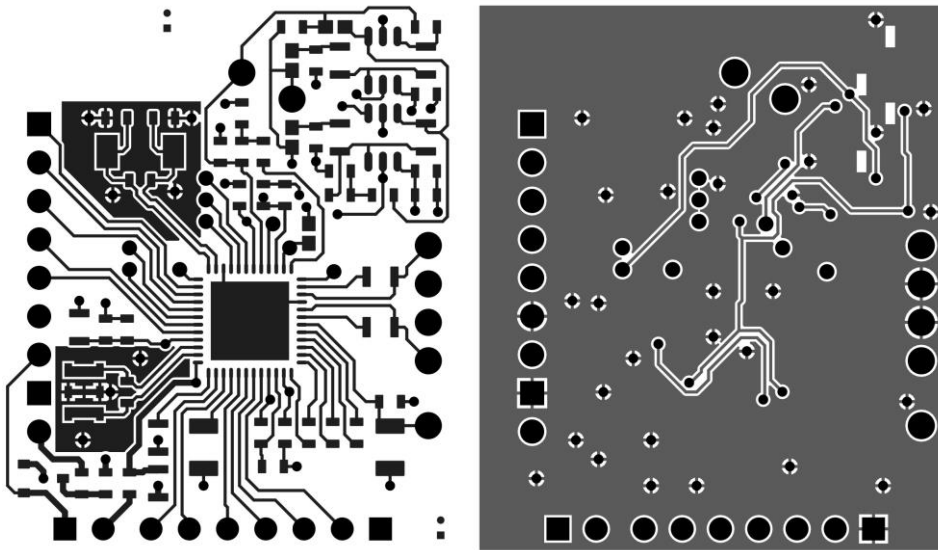

Figure 8: AS6040-QF_DK_RB layout 2:1t

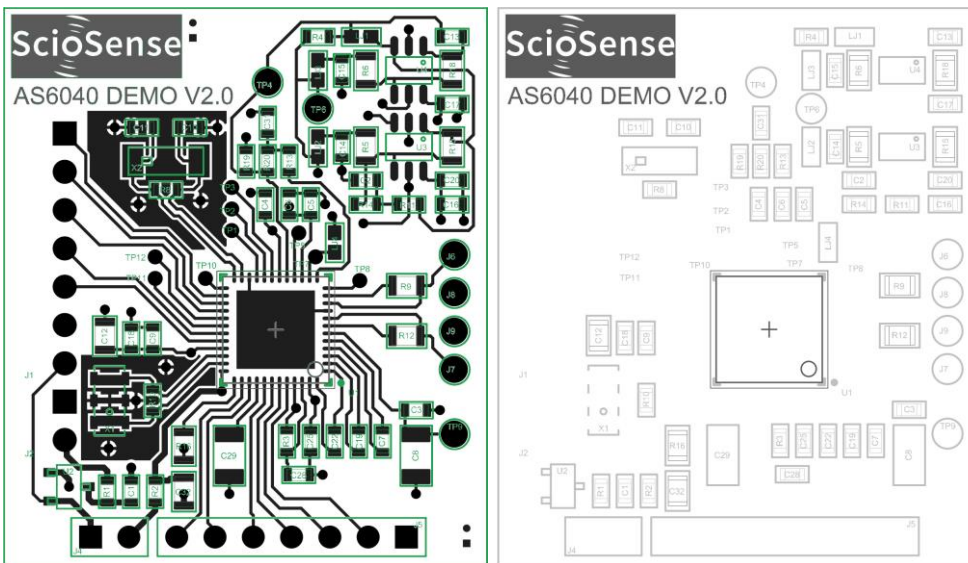

Figure 9: AS6040-QF_DK_RB assembly 2:1

Table 2: Bill of materials for AS6040-QF_DK_RB V2.0

Quantity	Designator	Value	Comment	Footprint
3	C1, C10, C11	10p	CHIP-CAPACITOR 0603	0603
1	C18	22p	CHIP-CAPACITOR 0603	0603
1	C31	10n	CHIP-CAPACITOR 0603	0603
5	C4, C5, C9, C25, C28	100n	CHIP-CAPACITOR 0603	0603

1	C6	680n	CHIP-CAPACITOR 0603	0603
1	C3	100n/25V	CHIP-CAPACITOR 0603	0603
2	C12, C32	100u/6V3	CHIP-CAPACITOR 0805	0603
1	C29	100n C0G	CHIP-CAPACITOR GRM31C5C1E104JA01L	1206
3	C7, C19, C22	2u2/16V	CHIP-CAPACITOR 603	0603
1	C8	22u/20V	Tantal BF. B TAJB226K020RNJ AVX	
7	C2, C13, C14, C15, C16, C17, C20		CHIP-CAPACITOR 0603	0603
3	R1, R2, R3	4R7	CHIP-RESISTOR 0603	0603
1	R20	2k2	CHIP-RESISTOR 0603	0603
1	R13	5k6	CHIP-RESISTOR 0603	0603
1	R10	560k	CHIP-RESISTOR 0603	0603
1	R8	10M	CHIP-RESISTOR 0603	0603
2	R9, R12	680R	CHIP-RESISTOR 0805	0805
1	R16	1K	CHIP-RESISTOR 0805 RN73C2A1K0B	
4	R4, R11, R14, R19		CHIP-RESISTOR 0603	0603
3	R5, R6, R15, R18		CHIP-RESISTOR 0805	0805
1	U1		AS6040-BQF	QFN48
2	U3, U4		LMP7711	
1	U2	3,0V	XC6206P302MR-G Torex	
1	X1	8Mhz	CERAMIC RESONATOR CSTNE8M00G550000R0	
1	X2	32,768kHz	Quartz Crystal KX-327XS	
1	J1		Male Connector 7x1x180° 2,54	
1	J2		Male Connector 2x1x180° 2,54	
1	J4		Male Connector 2x1x90° 2,54	

6 RoHS Compliance & ScioSense Green Statement

RoHS: The term RoHS compliant means that Sciosense B.V. products fully comply with current RoHS directives. Our semiconductor products do not contain any chemicals for all 6 substance categories, including the requirement that lead does not exceed 0.1% by weight in homogeneous materials. Where designed to be soldered at high temperatures, RoHS compliant products are suitable for use in specified lead-free processes.

ScioSense Green (RoHS compliant and no Sb/Br): ScioSense Green defines that in addition to RoHS compliance, our products are free of Bromine (Br) and Antimony (Sb) based flame retardants (Br or Sb do not exceed 0.1% by weight in homogeneous material).

Important Information: The information provided in this statement represents Sciosense B.V. knowledge and belief as of the date that it is provided. Sciosense B.V. bases its knowledge and belief on information provided by third parties, and makes no representation or warranty as to the accuracy of such information. Efforts are underway to better integrate information from third parties. Sciosense B.V. has taken and continues to take reasonable steps to provide representative and accurate information but may not have conducted destructive testing or chemical analysis on incoming materials and chemicals. Sciosense B.V. and Sciosense B.V. suppliers consider certain information to be proprietary, and thus CAS numbers and other limited information may not be available for release.

7 Copyrights & Disclaimer

Copyright Sciosense B.V High Tech Campus 10, 5656 AE Eindhoven, The Netherlands. Trademarks Registered. All rights reserved. The material herein may not be reproduced, adapted, merged, translated, stored, or used without the prior written consent of the copyright owner.

Devices sold by Sciosense B.V. are covered by the warranty and patent indemnification provisions appearing in its General Terms of Trade. Sciosense B.V. makes no warranty, express, statutory, implied, or by description regarding the information set forth herein. Sciosense B.V. reserves the right to change specifications and prices at any time and without notice. Therefore, prior to designing this product into a system, it is necessary to check with Sciosense B.V. for current information. This product is intended for use in commercial applications. Applications requiring extended temperature range, unusual environmental requirements, or high reliability applications, such as military, medical life-support or life-sustaining equipment are specifically not recommended without additional processing by Sciosense B.V. for each application. This product is provided by Sciosense B.V. "AS IS" and any express or implied warranties, including, but not limited to the implied warranties of merchantability and fitness for a particular purpose are disclaimed.

Sciosense B.V. shall not be liable to recipient or any third party for any damages, including but not limited to personal injury, property damage, loss of profits, loss of use, interruption of business or indirect, special, incidental or consequential damages, of any kind, in connection with or arising out of the furnishing, performance or use of the technical data herein. No obligation or liability to recipient or any third party shall arise or flow out of Sciosense B.V. rendering of technical or other services.

8 Revision information

Table 3: Revision history

Revision	Date	Comment	Page
1.0	2019	Initial version, preliminary	All
2.0	2020 Jun 06	Release	All
3.0	2021 Apr 20	Part description corrected, reference to new UfcEvaluation Software	All
4.0	2021 Oct 22	Reference to update schematics and layout of reference board. PICOPROG picture. Transfer into new SciSense layout	All
5.0	2023 Mar 01	PICOPROG V3.0 replaced by PICOPROG Lite	3

Note(s) and/or Footnote(s):

1. Page and figure numbers for the previous version may differ from page and figure numbers in the current revision.
2. Correction of typographical errors is not explicitly mentioned.