



## User Guide

UG000440

# AS6204

## Eval Kit

AS6204-EK

v1-01 • 2019-Apr-17

---

---

# Content Guide

---

<b>1</b>	<b>Introduction.....</b>	<b>3</b>	4.2	Temperature Register .....	8
1.1	Kit Content.....	3	<b>5</b>	<b>Schematics, Layers and BOM .....</b>	<b>9</b>
1.2	Ordering Information .....	3	5.1	Schematics.....	9
<b>2</b>	<b>Getting Started.....</b>	<b>4</b>	5.2	Layout and Board Dimensions.....	9
<b>3</b>	<b>Hardware Description.....</b>	<b>5</b>	5.3	Bill of Materials.....	11
3.1	Hardware Architecture .....	5	<b>6</b>	<b>Revision Information.....</b>	<b>12</b>
3.2	AS6204 Configuration .....	6	<b>7</b>	<b>Legal Information .....</b>	<b>13</b>
3.3	Power Supply and Connections .....	6			
<b>4</b>	<b>Software Description.....</b>	<b>7</b>			
4.1	Index Register .....	7			

---

# 1 Introduction

---

The AS6204 adapter board is a small PCB allowing a simple and quick evaluation of the AS6204 digital temperature sensors without the need to design a custom PCB. This small form factor board is fully assembled with the AS6204 temperature sensor and its necessary external components.

---

## 1.1 Kit Content

This kit contains following material listed in Figure 1

**Figure 1:**  
**Kit Content**

Pos.	Item	Comment
1	AS6204-EK-AB	Eval Kit Adapter Board

---

---

## 1.2 Ordering Information

**Figure 2:**  
**Ordering Code**

Ordering Code	Description
AS6204-EK	AS6204 Eval Kit

---

## 2 Getting Started

The AS6204 adapter board is ideal for rapid setup of a digital temperature sensor. To get started connect the board to your microcontroller configuration as described in Figure 4. Add a command in your source code to request two bytes from the selected I<sup>2</sup>C address. Finally convert the returned data as described in chapter 4.2 to get the actual temperature value.

**Figure 3:**  
**Adapter Board**

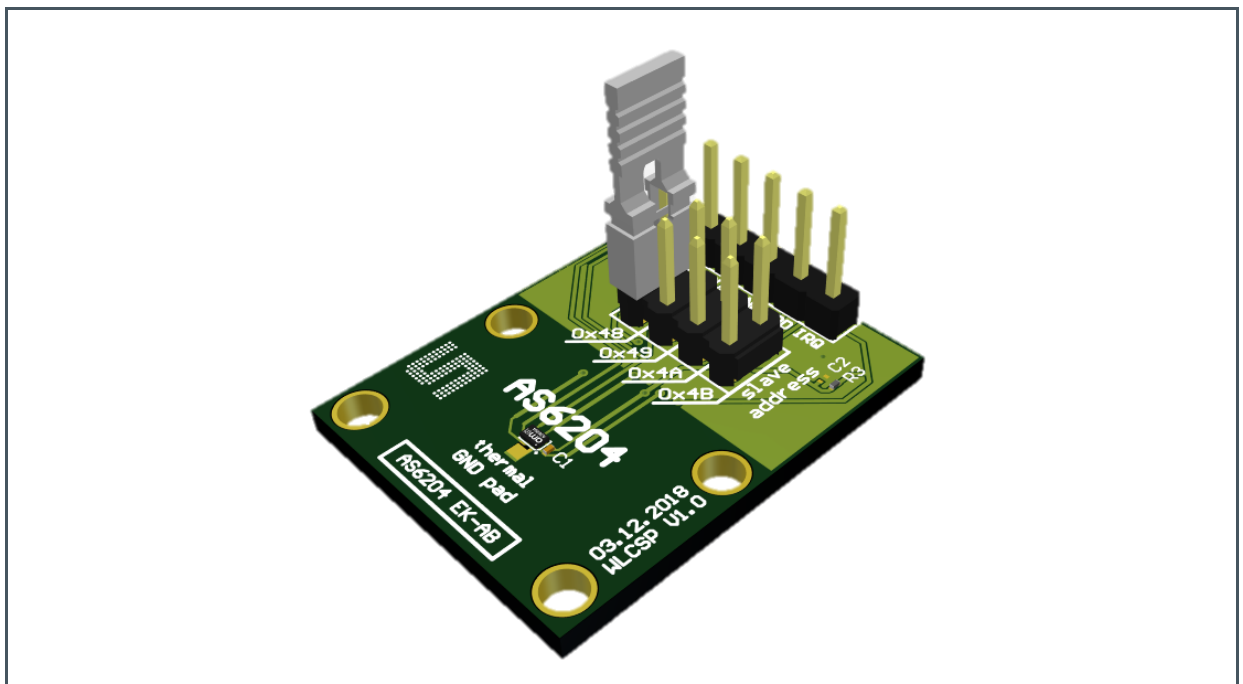

### 3 Hardware Description

The P1 connector does provide all relevant signals, which can be easily wired to a microcontroller and to the power supply

**Figure 4:**  
Adapter Board Pin-Out

Pin	Symbol	Description	Info
1	SCL	I <sup>2</sup> C clock	Use R1 if pull-up is required
2	SDA	I <sup>2</sup> C data	Use R2 if pull-up is required
3	GND	Ground	
4	VDD	Power supply	According datasheet
5	IRQ	Digital output pin	Alert interrupt output

#### 3.1 Hardware Architecture

**Figure 5:**  
AS6204 Adapter Board

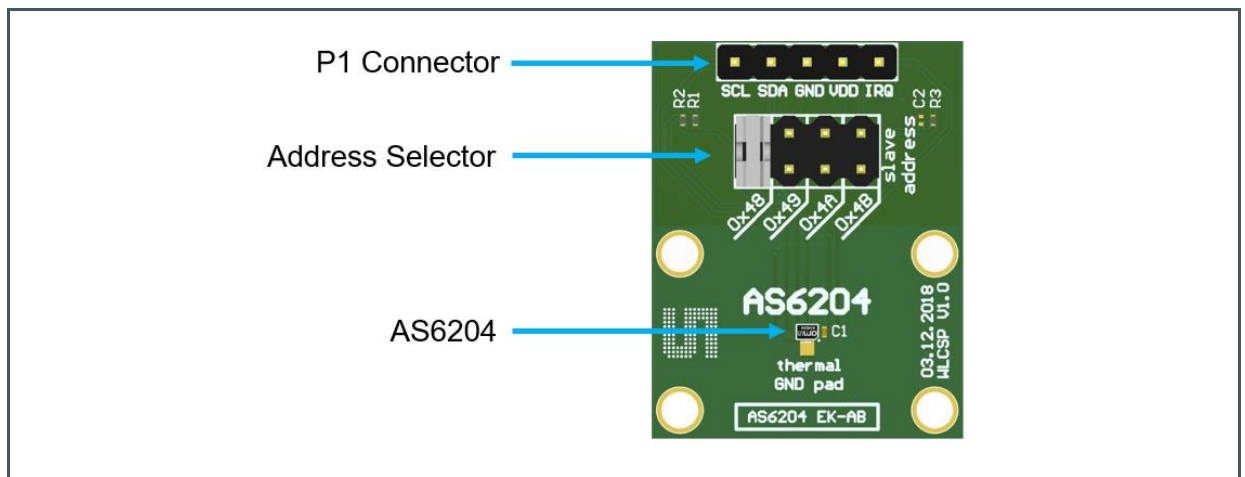



R1, R2 and R3 are pull-up resistors for the I<sup>2</sup>C interface and the Alert pin. Depending on the application, it is recommended to either populate the decoupling capacitor C1 or C2.

### 3.2 AS6204 Configuration

With the address selector, it is possible to choose the I<sup>2</sup>C address of the device. The included jumper is an easy way of setting the I<sup>2</sup>C address of the sensor. The address selector must not be left open.

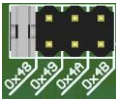
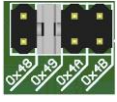
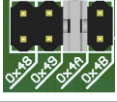
**Figure 6:**  
I<sup>2</sup>C Address

Jumper Settings	Address Selector	Device Address
	GND	100 1000 0x48
	VDD	100 1001 0x49
	SDA	100 1010 0x4A
	SCL	100 1011 0x4B

### 3.3 Power Supply and Connections

The PCB has to be connected to an external microcontroller. P1 is populated with a 1x5 pin header and is required for power supply as well as I<sup>2</sup>C communication. In addition to that, it can be used to monitor the interrupt status via pin 5 (IRQ).

**Figure 7:**  
MCU and AS6204 Connections

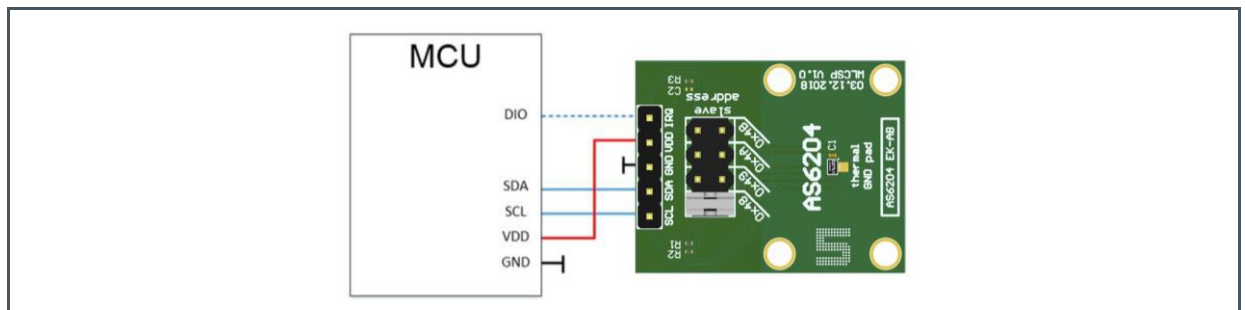

## 4 Software Description

The AS6204 has 4 data registers. With the use of the index register, it is possible to address the specific data register. When powered up the address register is set to 0x0.

**Figure 8:**  
Data Registers

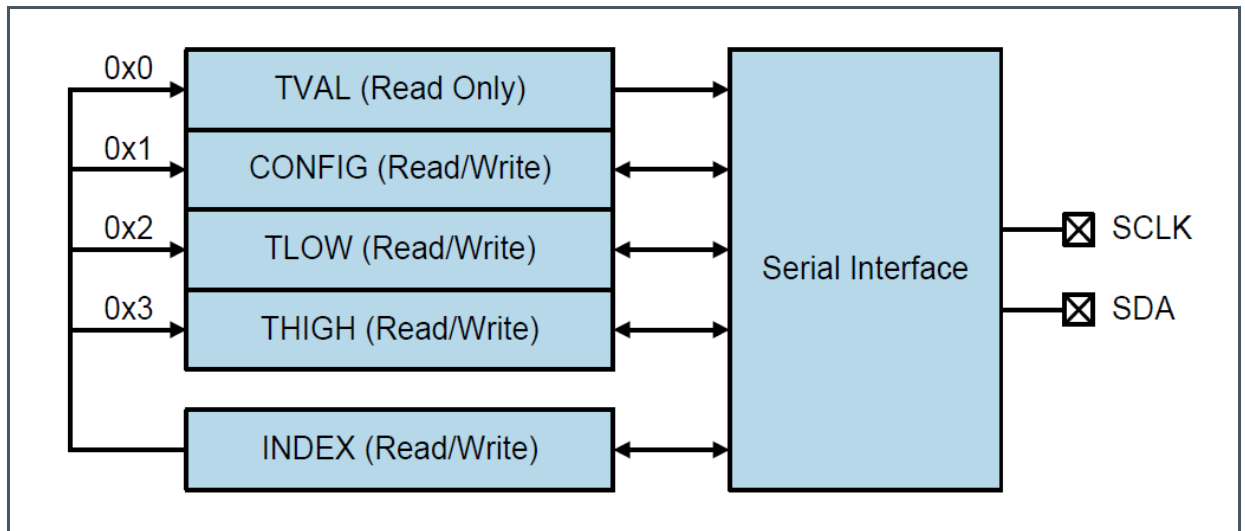

For additional configuration settings, the Config register (0x1) has to be addressed. Please refer the data sheet for details.

**Figure 9:**  
Configuration Register

Address	Symbol	Register	Description
0x0	TVAL		Contains the temperature value
0x1	CONFIG	Configuration Register	Configuration settings of the temperature sensor
0x2	TLOW	T <sub>LOW</sub> Register	Low temperature threshold value
0x3	THIGH	T <sub>HIGH</sub> Register	High temperature threshold value

### 4.1 Index Register

The index register contains 8-bit, but only D0 and D1 are used.

**Figure 10:**  
**Index Register**

Bit	D7	D6	D5	D4	D3	D2	D1	D0
Value	0	0	0	0	0	0	Address Bits	

## 4.2 Temperature Register

**Figure 11:**  
**Temperature Register**

D15	D14	D13	D12	D11	D10	D9	D8	D7	D6	D5	D4	D3	D2	D1	D0
T11	T10	T9	T8	T7	T6	T5	T4	T3	T2	T1	T0	0	0	0	0
MSB Byte								LSB Byte							

The temperature register contains the digitally converted temperature value. It consists of 2 bytes and can be converted according to the following formula:

Positive values=  $|Value| / LSB$

Negative values=  $Complement(|Value| / LSB) + 1$

**Example +75°C**

$$75^{\circ}C / 0.0625^{\circ}C = 1200 = Binary\ 0100\ 1011\ 0000 = Hex\ 4B0$$

**Example -40°C**

$$|-40^{\circ}C| / 0.0625^{\circ}C + 1 = 640 + 1 = Binary\ 0010\ 1000\ 0000 + 1 = 1101\ 0111\ 1111 + 1 = 1101\ 10000\ 0000 = Hex\ D80$$



# 5 Schematics, Layers and BOM

The schematics, layout and BOM of the adapter board are shown below for reference.

## 5.1 Schematics

The schematics of the board is shown below in Figure 12:

**Figure 12:**  
**Schematics**

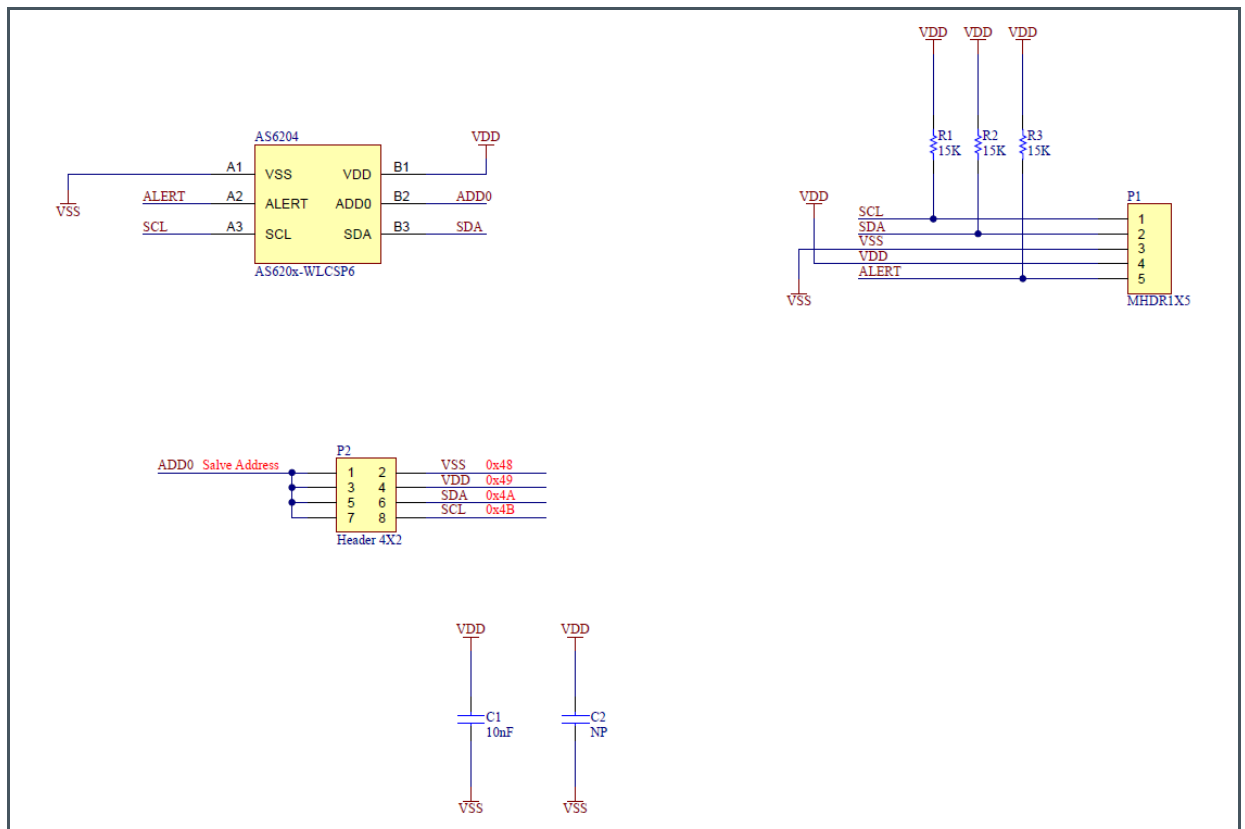

## 5.2 Layout and Board Dimensions.

The PCB layout is shown below in Figure 13 and Figure 14

Figure 13:  
Top Layer

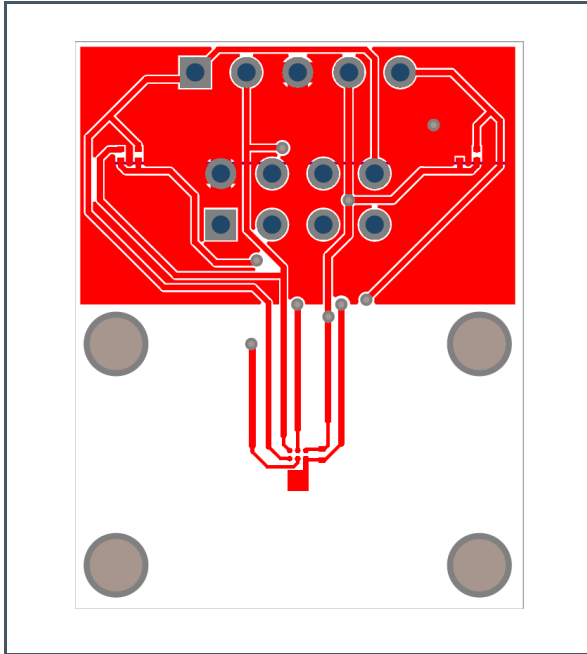
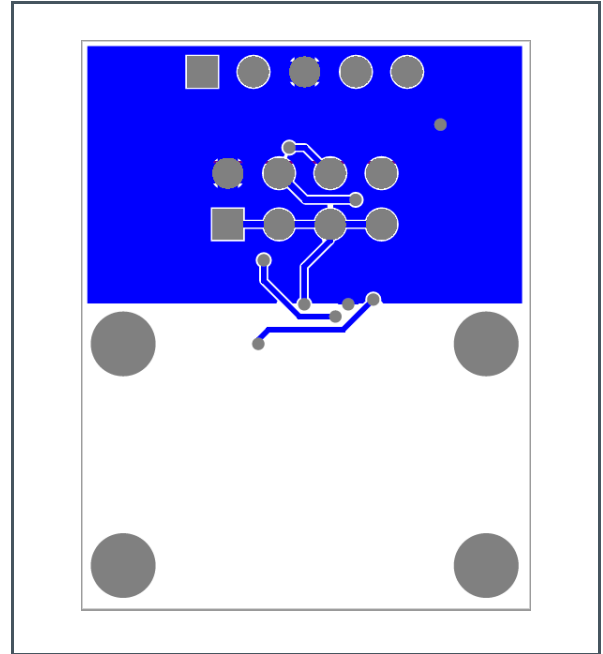
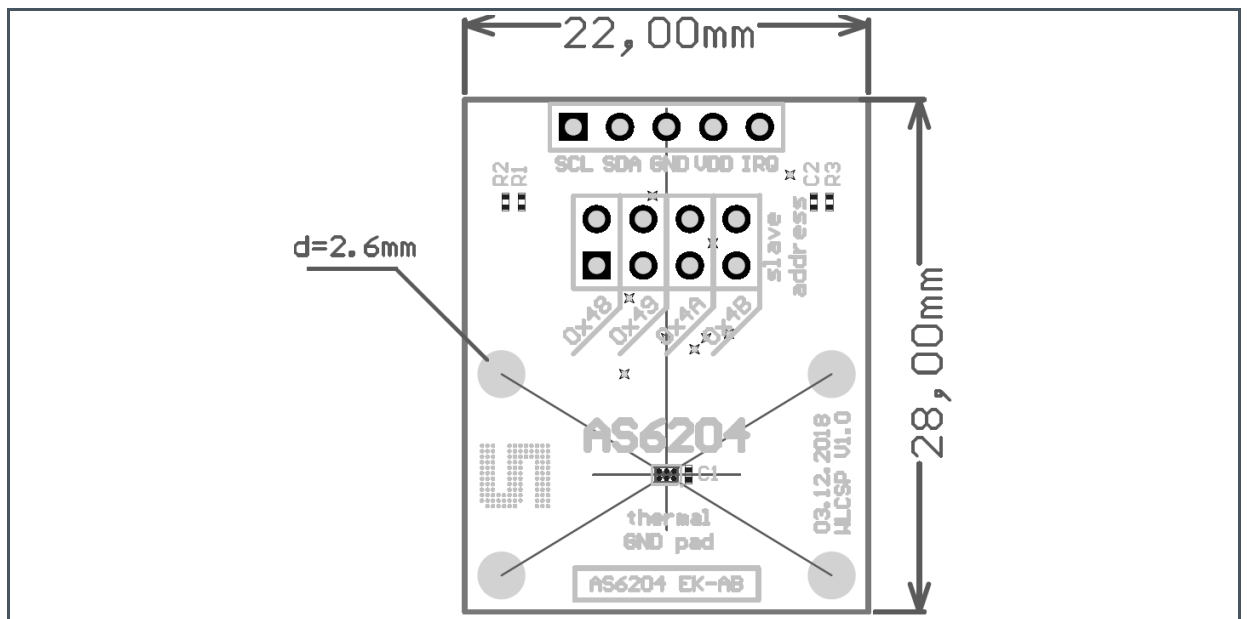

Figure 14:  
Bottom Layer



The board dimensions are shown below in Figure 15

Figure 15:  
Dimensions



## 5.3 Bill of Materials

The BOM of the Board is shown below in Figure 16

**Figure 16:**  
**BOM**

Position	Name	Value
1	R7	NP
2	R6	NP
3	R5	NP
4	R4	NP
5	R3	10 K
6	R2	10 K
7	R1	10 K
8	P1	Header 5
9	C2	NP
10	C1	10 nF
11	AS6204	AS6204 WLCSP

# 6 Revision Information

Changes from previous version to current revision v1-01	Page
Initial version	

- Page and figure numbers for the previous version may differ from page and figure numbers in the current revision.
- Correction of typographical errors is not explicitly mentioned.