



User Guide

UG000452

AS621x

Eval Kit

AS6212-EK, AS6214-EK & AS6218-EK

v1-01 • 2019-Oct-08

Content Guide

1	Introduction.....	3	4.2	Temperature Register	9
1.1	Kit Content.....	3	5	Schematics, Layers and BOM	11
1.2	Ordering Information	3	5.1	Schematics.....	11
2	Getting Started.....	4	5.2	Layout and Board Dimensions.....	11
3	Hardware Description.....	5	5.3	Bill of Materials.....	13
3.1	Hardware Architecture	5	6	Revision Information.....	14
3.2	AS621x Configuration	6	7	Legal Information	15
3.3	Power Supply and Connections	7			
4	Software Description.....	8			
4.1	Index Register	8			

1 Introduction

The AS621x Eval Kit is a small PCB allowing a simple and quick evaluation of the AS621x digital temperature sensors without the need to design a custom PCB. This small form factor board is fully assembled with the AS621x temperature sensor and its necessary external components.

1.1 Kit Content

This kit contains following material listed in Figure 1

Figure 1:
Kit Content

Pos.	Item	Comment
1	AS621x-EK	Eval Kit

1.2 Ordering Information

Figure 2:
Ordering Code

Ordering Code	Description
AS6212-EK	AS6212 Eval Kit up to 0.2 °C accuracy
AS6214-EK	AS6214 Eval Kit up to 0.4 °C accuracy
AS6218-EK	AS6218 Eval Kit up to 0.8 °C accuracy

2 Getting Started

The AS621x Eval Kit is ideal for rapid setup of a digital temperature sensor. To get started connect the board to your microcontroller as described in Figure 4. Add a command in your source code to request two bytes from the selected I²C address. Finally convert the returned data as described in chapter 4.2 to get the actual temperature value.

Figure 3:
Eval Kit

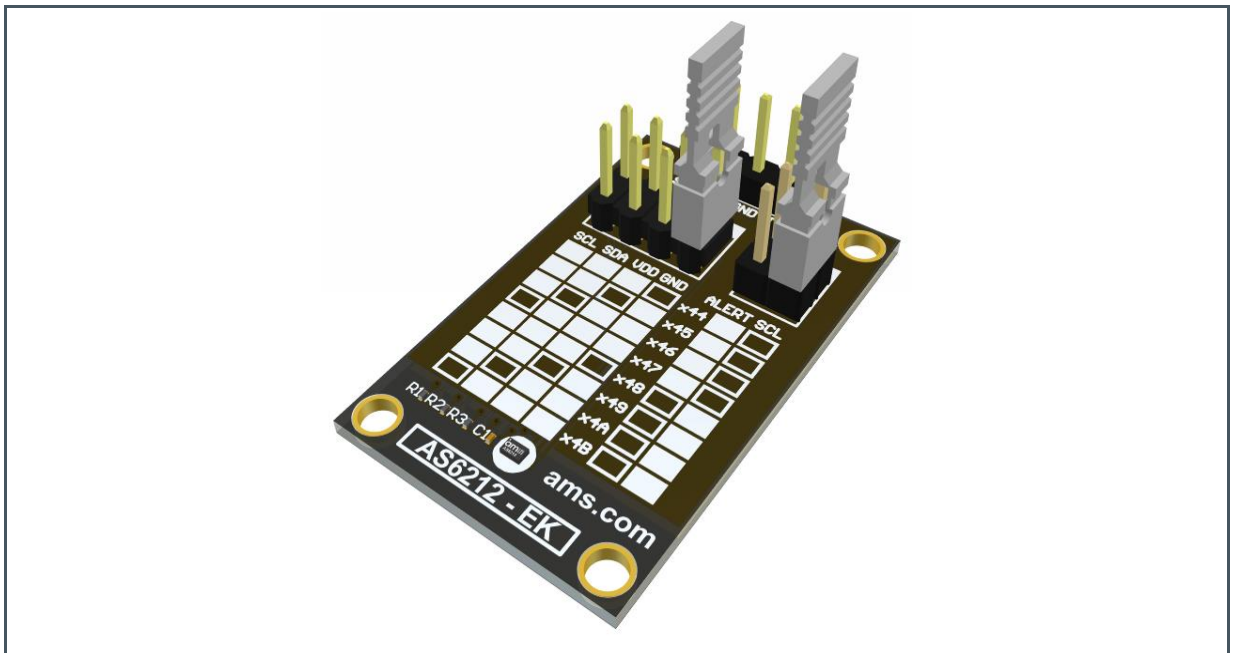

3 Hardware Description

The P1 connector does provide all relevant signals, which can be easily wired to a microcontroller and to the power supply.

Figure 4:
Eval Kit Pin-Out

Pin	Symbol	Description	Info
1	SCL	I ² C clock	Use R1 if pull-up is required
2	SDA	I ² C data	Use R2 if pull-up is required
3	GND	Ground	
4	VDD	Power supply	According datasheet
5 ⁽¹⁾	ALERT	Digital output pin	Alert interrupt output

(1) Do not connect pin 5 to VSS. This pin should only be used for the ALERT functionality

3.1 Hardware Architecture

Figure 5:
AS621x Eval Kit

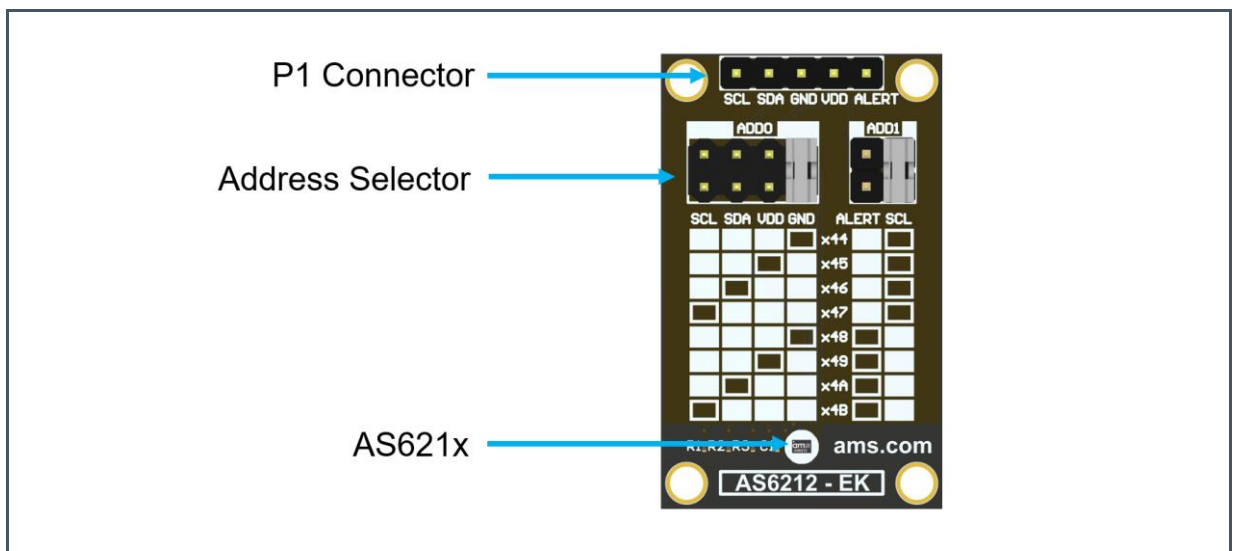





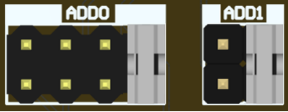

R1, R2 and R3 are pull-up resistors for the I²C interface and the ALERT pin. Depending on the application, it is recommended to either populate the decoupling capacitor C1.

3.2 AS621x Configuration

With the address selector, it is possible to choose the I²C address of the device. The included jumpers are an easy way of setting the I²C address of the sensor. Both address selectors must not be left open.

Figure 6:
I²C Address

Jumper Settings	Address Selector ADD0	Address Selector ADD1	Device Address Binary	HEX
	GND	SCL	100 0100	0x44
	VDD	SCL	100 0101	0x45
	SDA	SCL	100 0110	0x46
	SCL	SCL	100 0111	0x47
	GND	ALERT functionality	100 1000	0x48
	VDD	ALERT functionality	100 1001	0x49
	SDA	ALERT functionality	100 1010	0x4A
	SCL	ALERT functionality	100 1011	0x4B

3.3 Power Supply and Connections

The PCB has to be connected to an external microcontroller. P1 is populated with a 1x5 pin header and is required for power supply as well as I²C communication. In addition to that, it can be used to monitor the interrupt status via pin 5 (IRQ).

Figure 7:
MCU and AS621x Connections

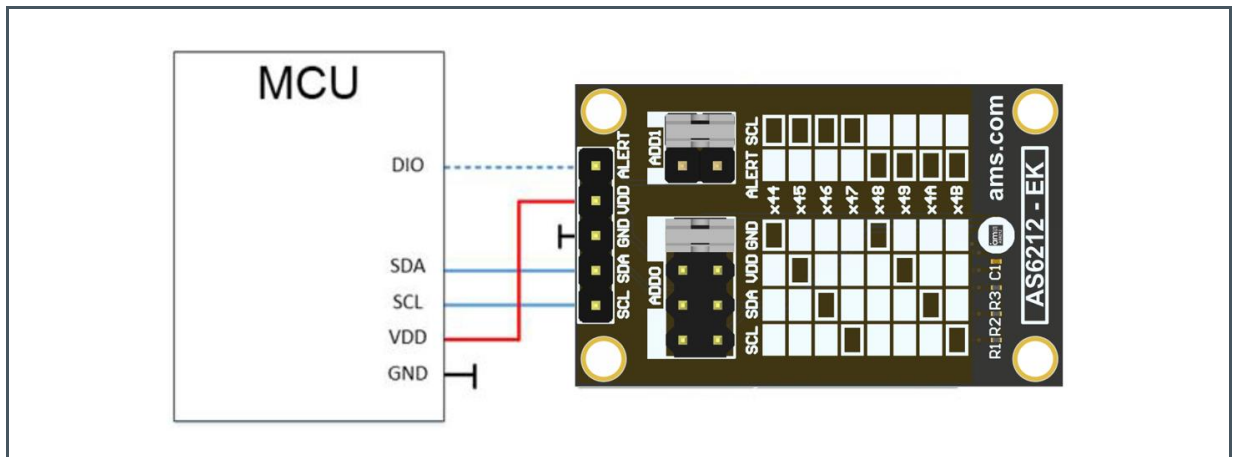

4 Software Description

The AS621x has 4 data registers. With the use of the index register, it is possible to address the specific data register. When powered up the address register is set to 0x0.

Figure 8:
Data Registers

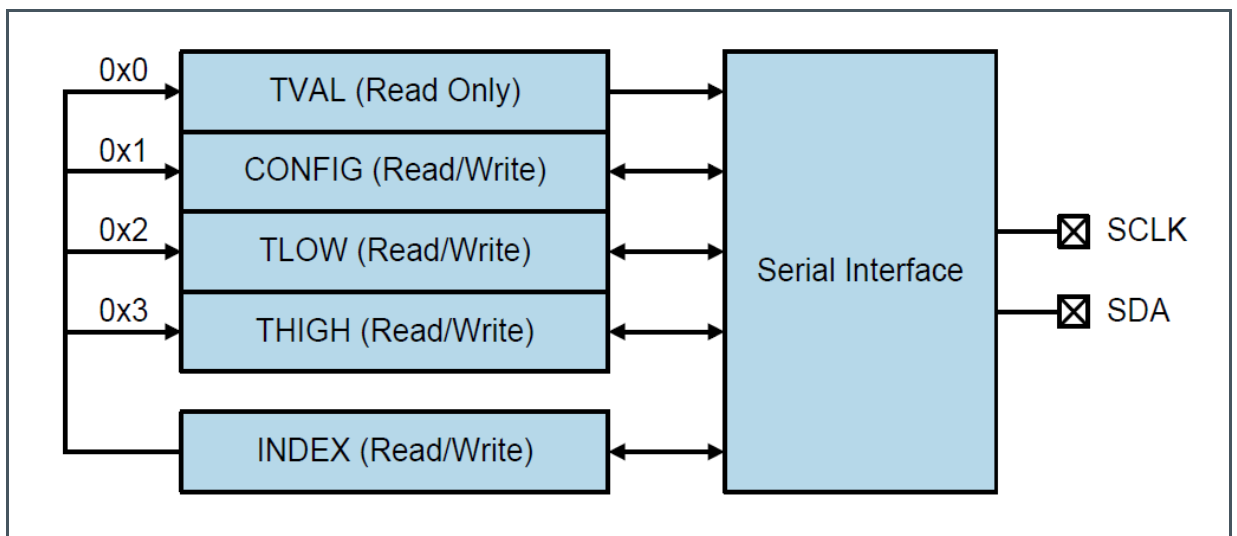

For additional configuration settings, the Config register (0x1) has to be addressed. Please refer to the datasheet for details.

Figure 9:
Configuration Register

Address	Symbol	Register	Description
0x0	TVAL		Contains the temperature value
0x1	CONFIG	Configuration Register	Configuration settings of the temperature sensor
0x2	TLOW	T _{LOW} Register	Low temperature threshold value
0x3	THIGH	T _{HIGH} Register	High temperature threshold value

4.1 Index Register

The index register contains 8-bit, but only D0 and D1 are used.

Figure 10:
Index Register

Bit	D7	D6	D5	D4	D3	D2	D1	D0
Value	0	0	0	0	0	0	Address Bits	

4.2 Temperature Register

Figure 11:
Temperature Register

D15	D14	D13	D12	D11	D10	D9	D8	D7	D6	D5	D4	D3	D2	D1	D0
T15	T14	T13	T12	T11	T10	T9	T8	T7	T6	T5	T4	T3	T2	T1	T0
MSB Byte								LSB Byte							

The temperature register contains the digitally converted temperature value. It consists of 2 bytes and can be converted according to the following formula:

Positive values= |Value| / LSB

Negative values= Complement(|Value| / LSB) + 1

Example +75°C

75°C / 0.0078125 °C = 9600 = Binary 0010 0101 1000 0000 = Hex 2800

Example -40°C

$| -40^{\circ}\text{C} / 0.0078125^{\circ}\text{C} + 1 = \overline{5120} + 1 = \text{Binary } \overline{0001\ 0100\ 0000\ 0000} + 1 = 1110\ 1100\ 0000\ 0000 = \text{Hex } \text{EC00}$

Figure 12
Temperature Conversion Examples

Temperature (°C)	Digital Output (Binary)	Digital Output (Hex)
100.0	0011 0010 0000 0000	3200
75.0	0010 0101 1000 0000	2580
50.0	0001 1001 0000 0000	1900
25.0	0000 1100 1000 0000	0C80
0.125	0000 0000 0001 0000	0010
0.0078125	0000 0000 0000 0001	0001
0.0	0000 0000 0000 0000	0000
-0.0078125	1111 1111 1111 1111	FFFF
-0.125	1111 1111 1111 0000	FFF0
-25.0	1111 0011 1000 0000	F380
-40.0	1110 1100 0000 0000	EC00

5 Schematics, Layers and BOM

The schematics, layout and BOM of the adapter board are shown below for reference.

5.1 Schematics

The schematics of the board is shown below in Figure 13:

Figure 13:
Schematics

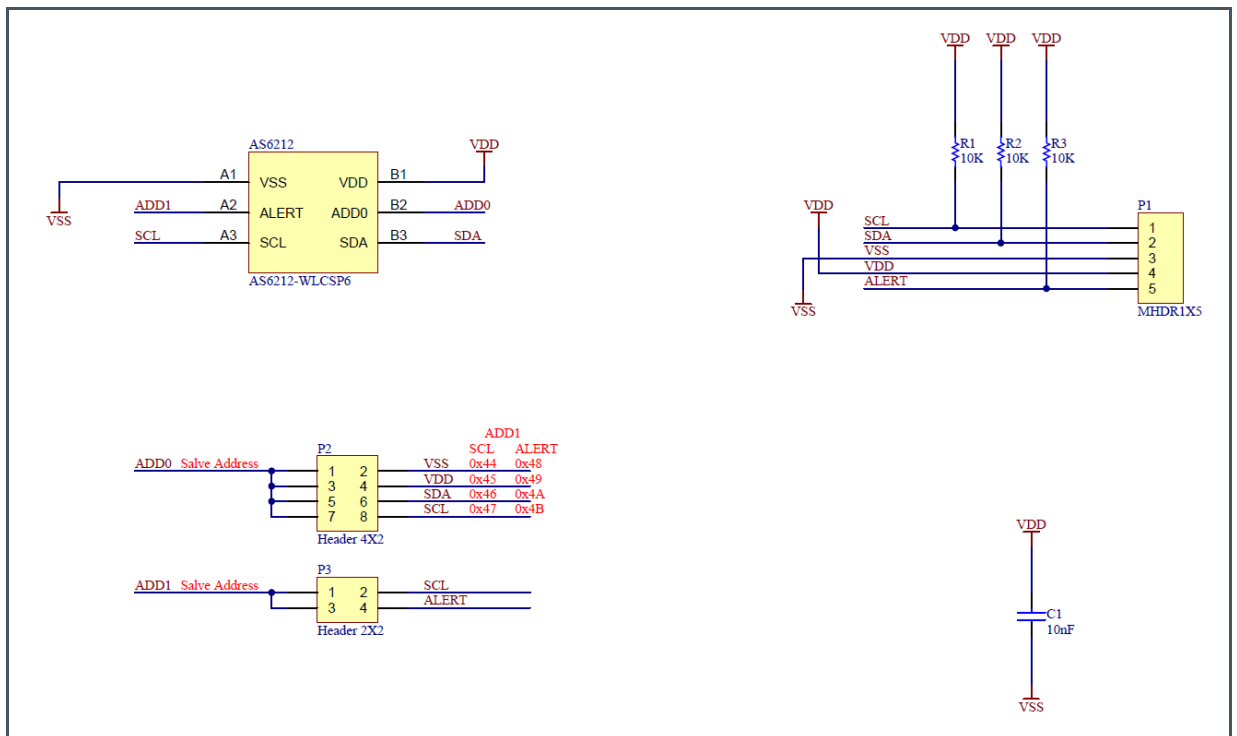

5.2 Layout and Board Dimensions.

The PCB layout is shown below in Figure 14 and Figure 15

Figure 14:
Top Layer

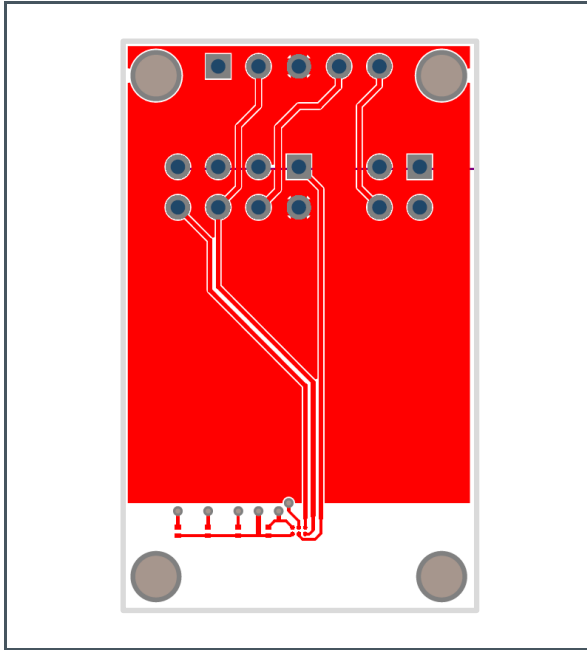
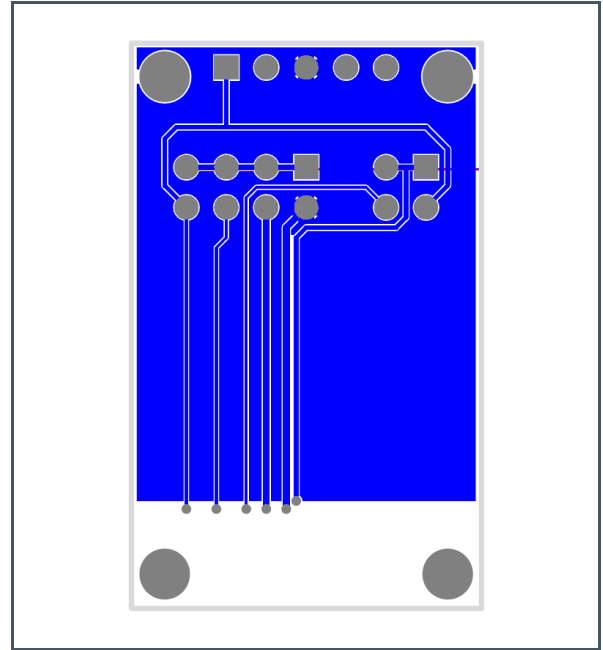
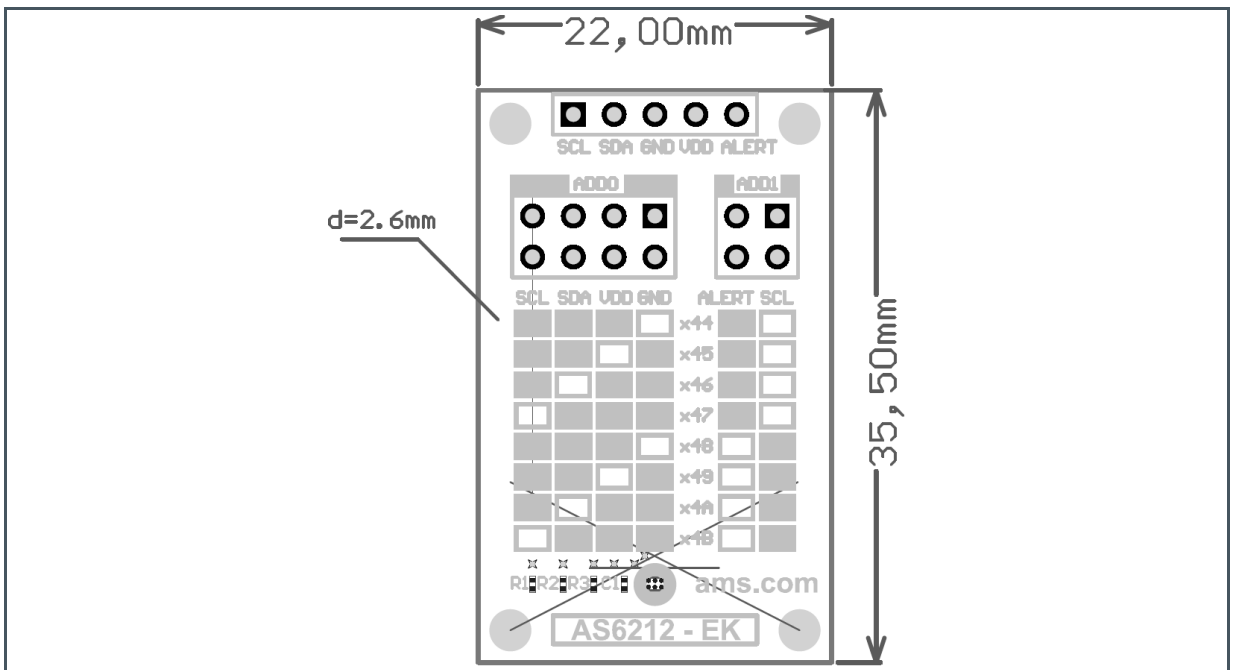

Figure 15:
Bottom Layer



The board dimensions are shown below in Figure 16

Figure 16:
Dimensions



5.3 Bill of Materials

The BOM of the Board is shown below in Figure 17

Figure 17:
BOM

Position	Name	Value
1	R3	10K
2	R2	10K
3	R1	10K
4	P3	Header 2X2
5	P2	Header 4X2
6	P1	Header 1X5
7	C1	10nF
8	AS621x	AS621x-WLCSP6

6 Revision Information

Changes from previous version to current revision v1-01	Page
Initial version	

- Page and figure numbers for the previous version may differ from page and figure numbers in the current revision.
- Correction of typographical errors is not explicitly mentioned.