



User Guide

UG001012

AS8579 Adapter Board

User Manual (HW/SW)

AS8579-SS_EK_AB

v1-00 • 2021-Apr-16

Content Guide

1	Introduction	3	3.1	Schematic	9
1.1	Kit Content.....	3	3.2	Layout	10
1.2	Ordering Information	4	4	Revision Information	11
2	Board Description	5	5	Legal Information.....	12
2.1	Detailed Description	6			
2.2	Pinout	7			
3	Hardware.....	9			

1 Introduction

This manual explains how to use the AS8579-SS_EK_AB hardware. The Hardware is designed to test and evaluate the features of AS8579 capacitive sensor. The AS8579 is a sensor, which measures the capacitive value by separately measuring the 10-bit Information (accumulated to 14-bit) of I and Q. This 14-bit information provides the capacitance of the application. The I and Q data can be read over a standard SPI interface.

For first setting up, please see application note: [AS8579_SPI_Configuration_AN001003_1-00](#).

1.1 Kit Content

Figure 1:
AS8579 Adapter Board Kit Content

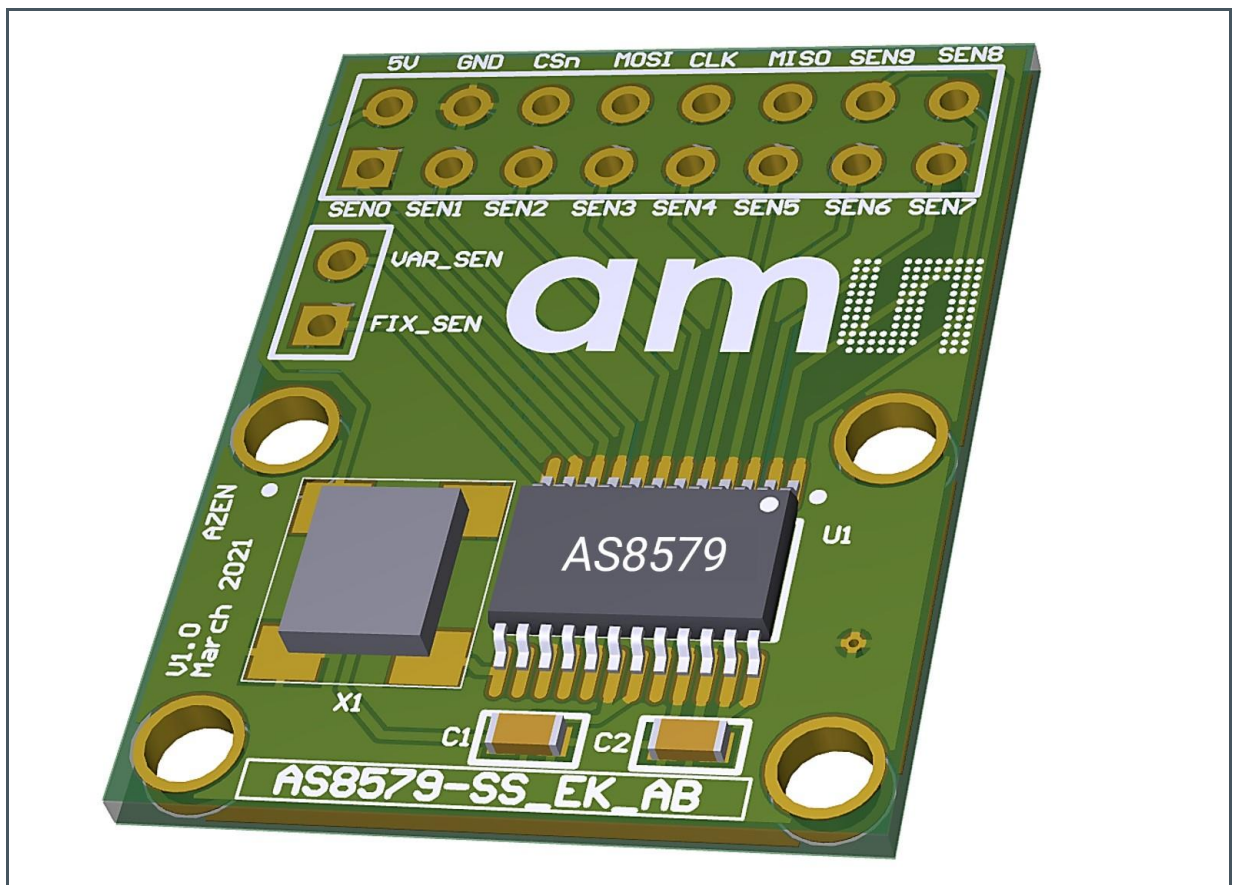

1.2 Ordering Information

Ordering Code	Description
AS8579-SS_EK_AB	AS8579 Adapter Board

2 Board Description

The PCB can be connected via standard SPI to a microcontroller. The Production-Programmer from SD4Y and the **ams** I&P-Box are also recommended tools for communication/programming interface.

If you want to connect the I&P box to the Adapter Board, a level shifter is needed (the I&P Box works with 3.3 V voltage levels).

The PCB is equipped with all necessary peripheral components for easy evaluation.

Figure 2:
AS8579 Adapter Board

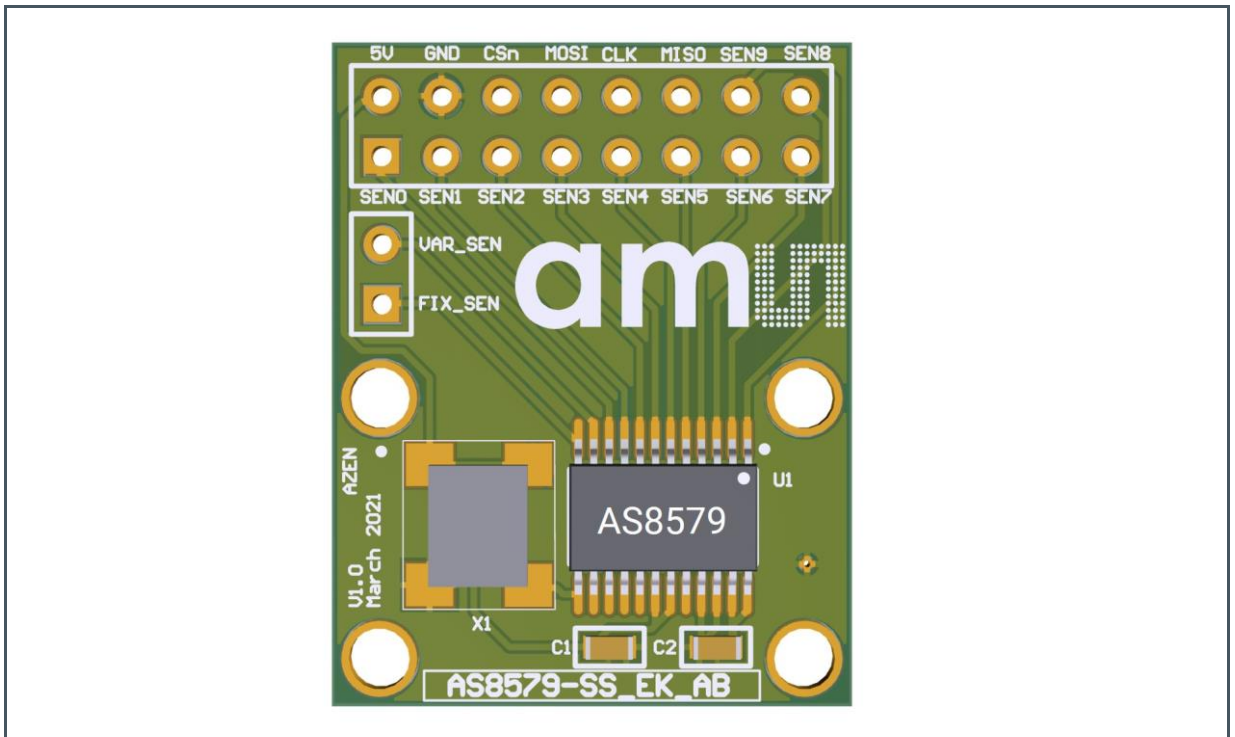

Figure 3:
BOM

Symbol	Description
U1	Capacitive sensor AS8579
C1	Capacitor 100 nF
C2	Capacitor 1 μ F
X1	Oscillator 48 MHz

2.1 Detailed Description

Figure 4:
AS8579 Adapter Board Overview

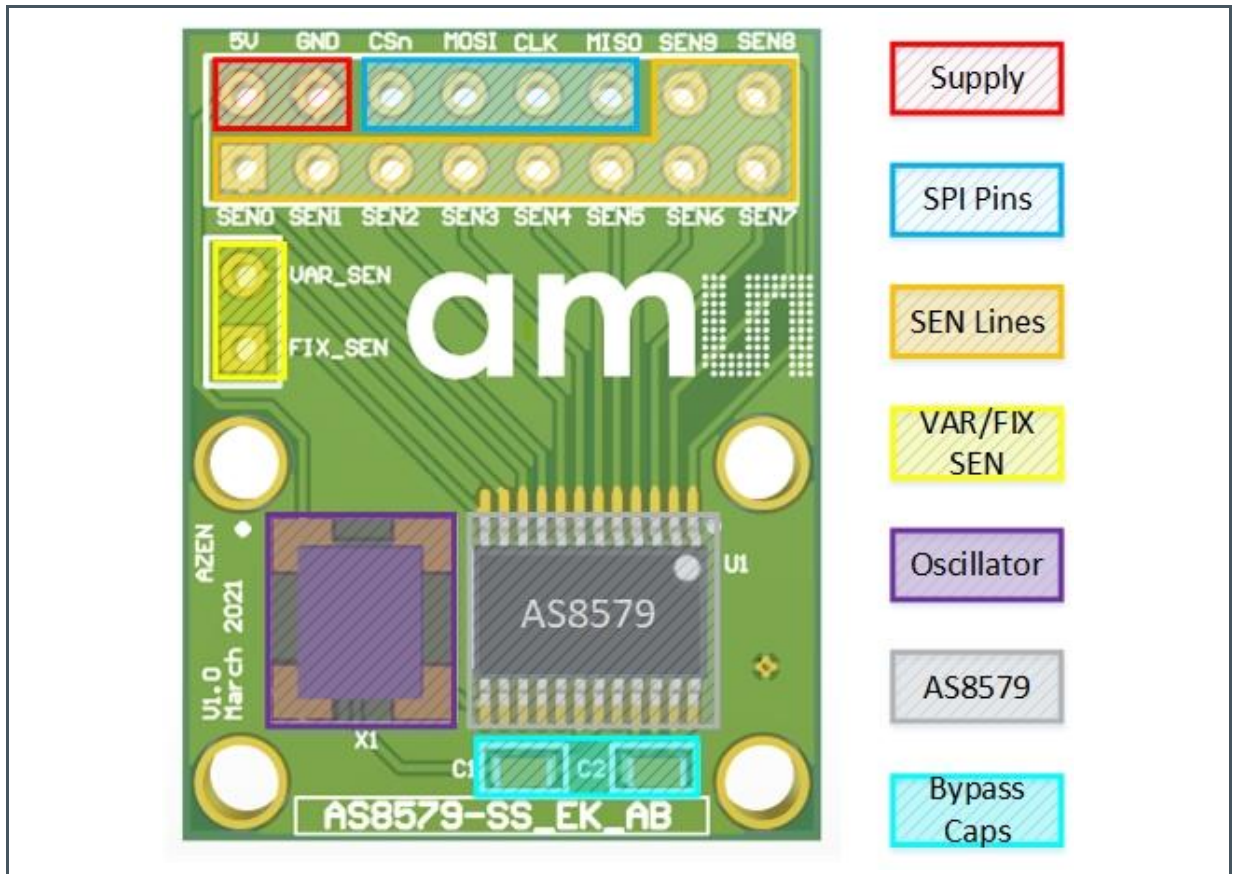

Figure 5:
Description

Components	Description
Supply	Pin 5 V supply and ground
SPI Pins	Communication and Programming Interface
SEN Lines	Sensing interface
VAR/ FIX SEN	Pins for cable and PCB shielding
Oscillator	Oscillator for clock generation of system clock frequency input Settings: EDIV=0000b (default value) -> CLK_E divider is 12 and resulting system clock is 4 Mz
AS8579	Capacitive sensor
Bypass Caps	Recommended decoupling capacitors

2.2 Pinout

Figure 6:
AS8579 Adapter Board Pinout

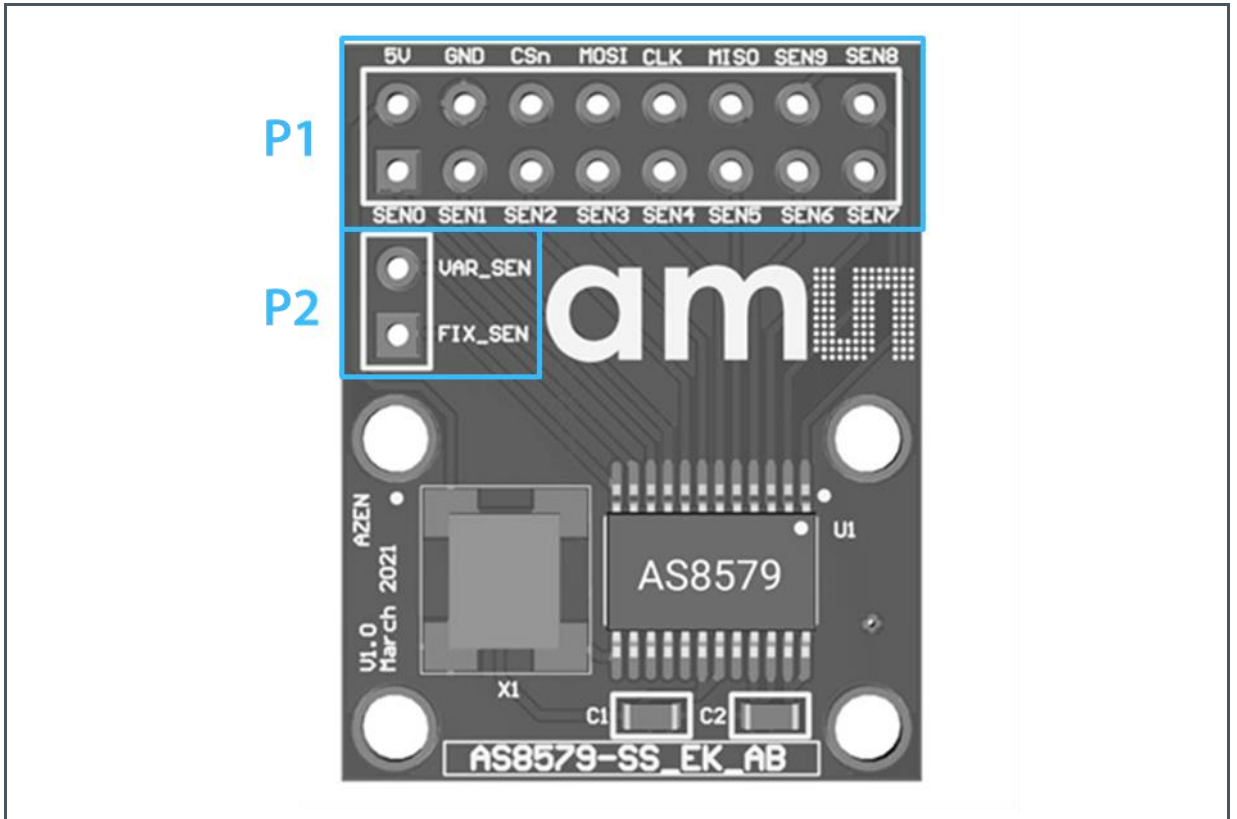

Figure 7:
Pinout

Pin #	Symbol	Description
P1-1	SEN0	Sensing Lines (0-7)
P1-2	SEN1	
P1-3	SEN2	
P1-4	SEN3	
P1-5	SEN4	
P1-6	SEN5	
P1-7	SEN6	
P1-8	SEN7	
P1-9	5V	5 V supply
P1-10	GND	Ground
P1-11	CSn	SPI – Chip select
P1-12	MOSI	SPI – Master out slave in
P1-13	CLK	SPI – Clock
P1-14	MISO	SPI – Master in slave out
P1-15	SEN9	Sensing Lines (8-9)
P1-16	SEN8	
P2-1	FIX_SEN	PCB shielding driver
P2-2	VAR_SEN	Cable shielding driver

3 Hardware

3.1 Schematic

Figure 8:
Schematic

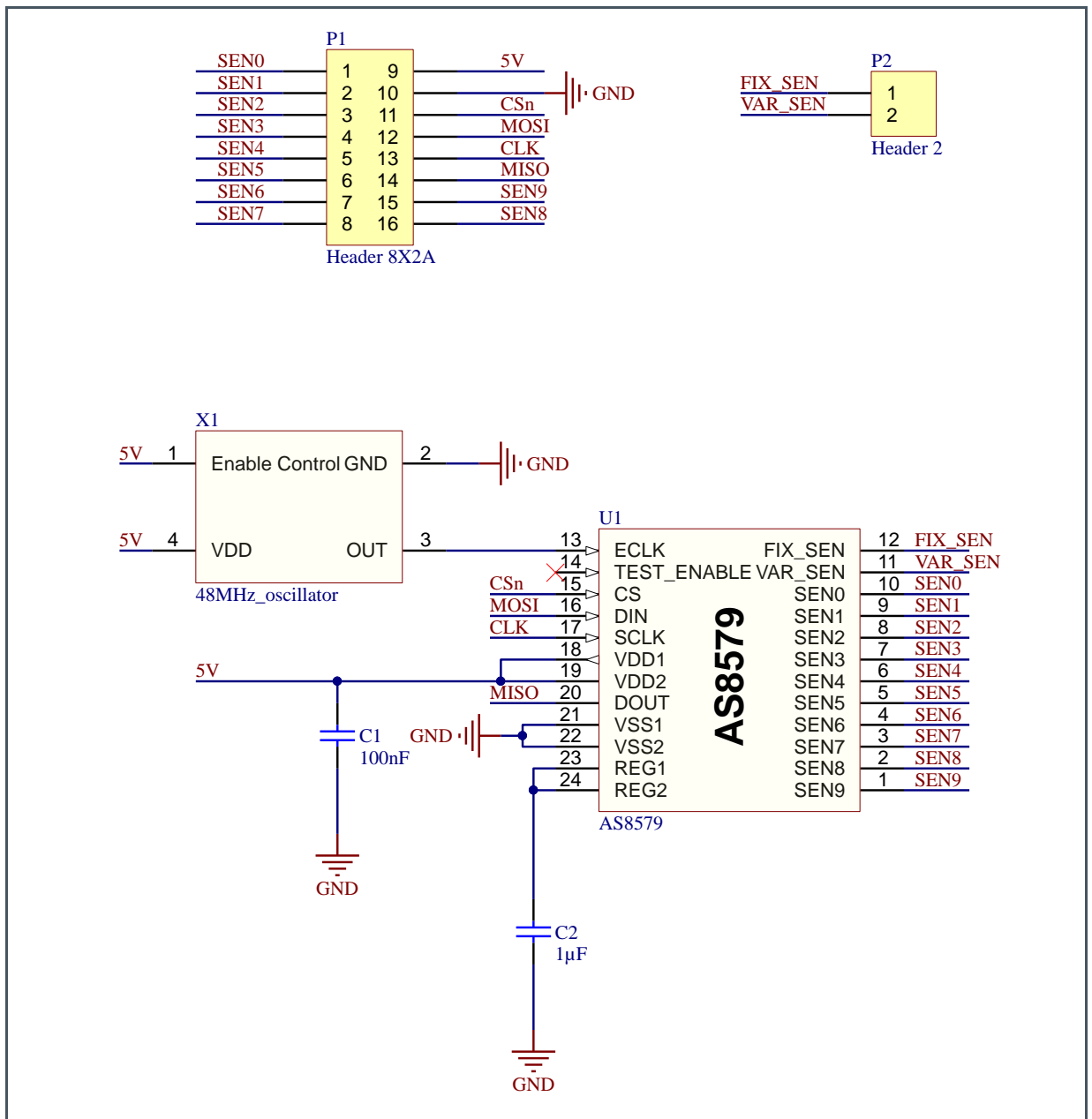

3.2 Layout

Figure 9:
PCB Layout

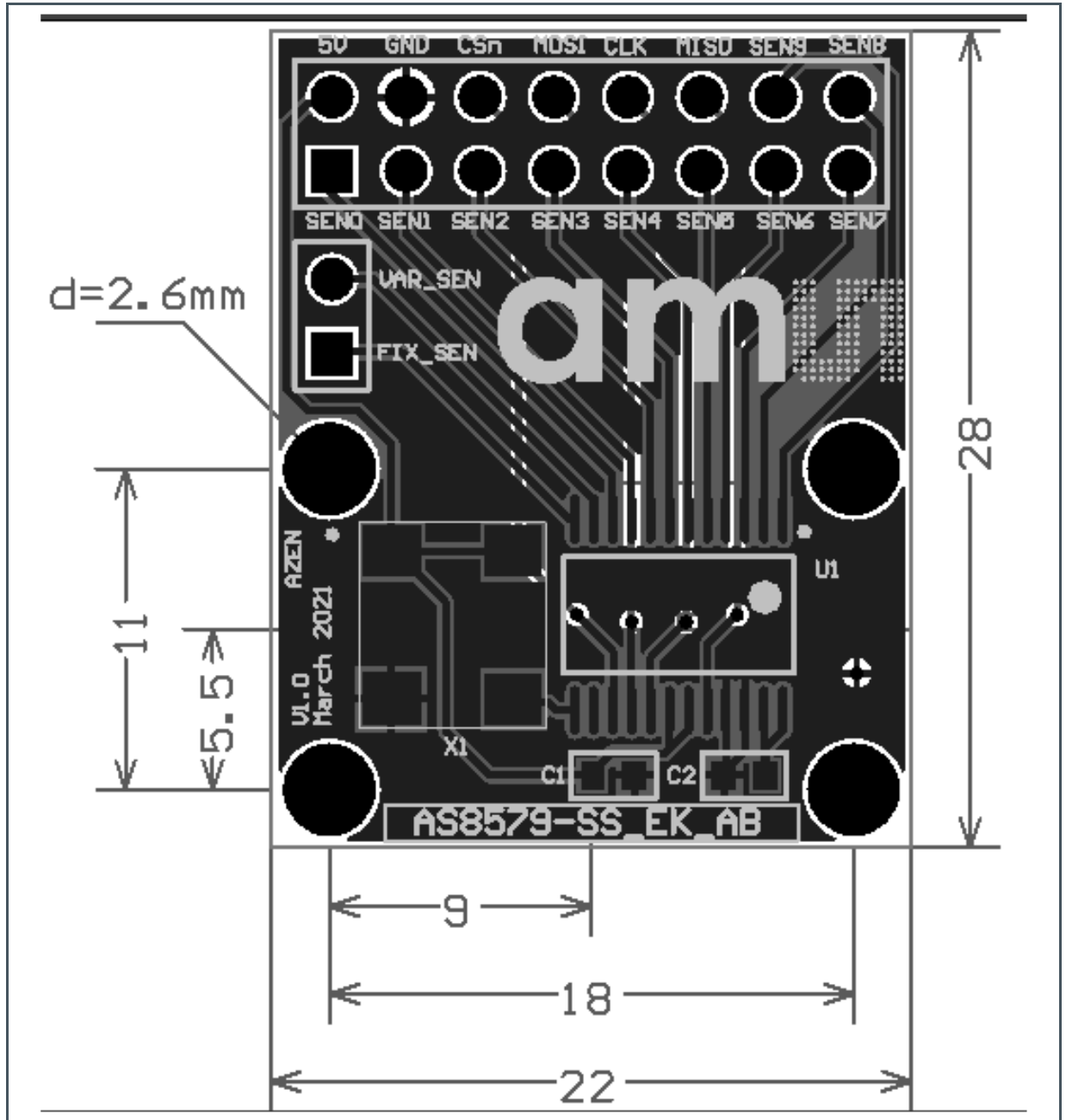

(1) All dimensions in mm.

4 Revision Information

Changes from previous version to current revision v1-00	Page
Initial production version	all

- Page and figure numbers for the previous version may differ from page and figure numbers in the current revision.
- Correction of typographical errors is not explicitly mentioned.