

ACS732 and ACS733 Evaluation Board

ACS732 AND ACS733 DEMO BOARD AND COMPONENTS

Allegro ACS732/33 demo board is pictured in Figure 1 below. Refer to Table 1 for symbol names and descriptions of onboard components. Note: Board is pictured without Allegro device.

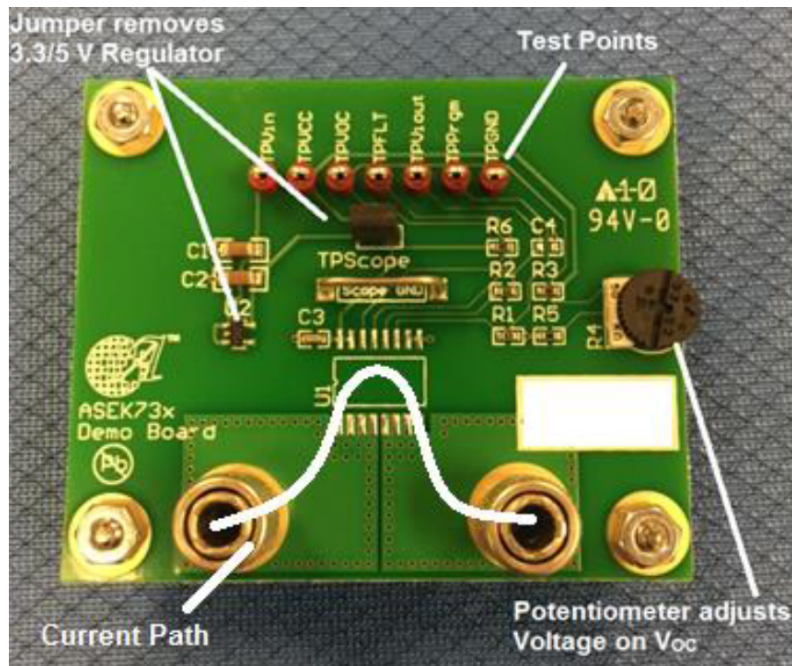

Figure 1: Allegro ACS733 Current Sensor Demo Board

Table 1: Summary of Demo Board Components

Symbol	Description
U1	Location of Allegro ACS733 ($V_{CC} = 3.3\text{ V}$) or ACS732 ($V_{CC} = 5\text{ V}$)
U2	3.3 or 5 V Regulator
Jumper	Removes regulator and capacitors C1, C2 from V_{CC} ; C3 (0.1 μF) still present at device
C1, C2	Regulator output capacitors; removed from the circuit via the jumper
C3	0.1 μF device bypass capacitor; is always connected
R4	Potentiometer to set voltage on V_{OC} pin; V_{OC} voltage sets fault current level

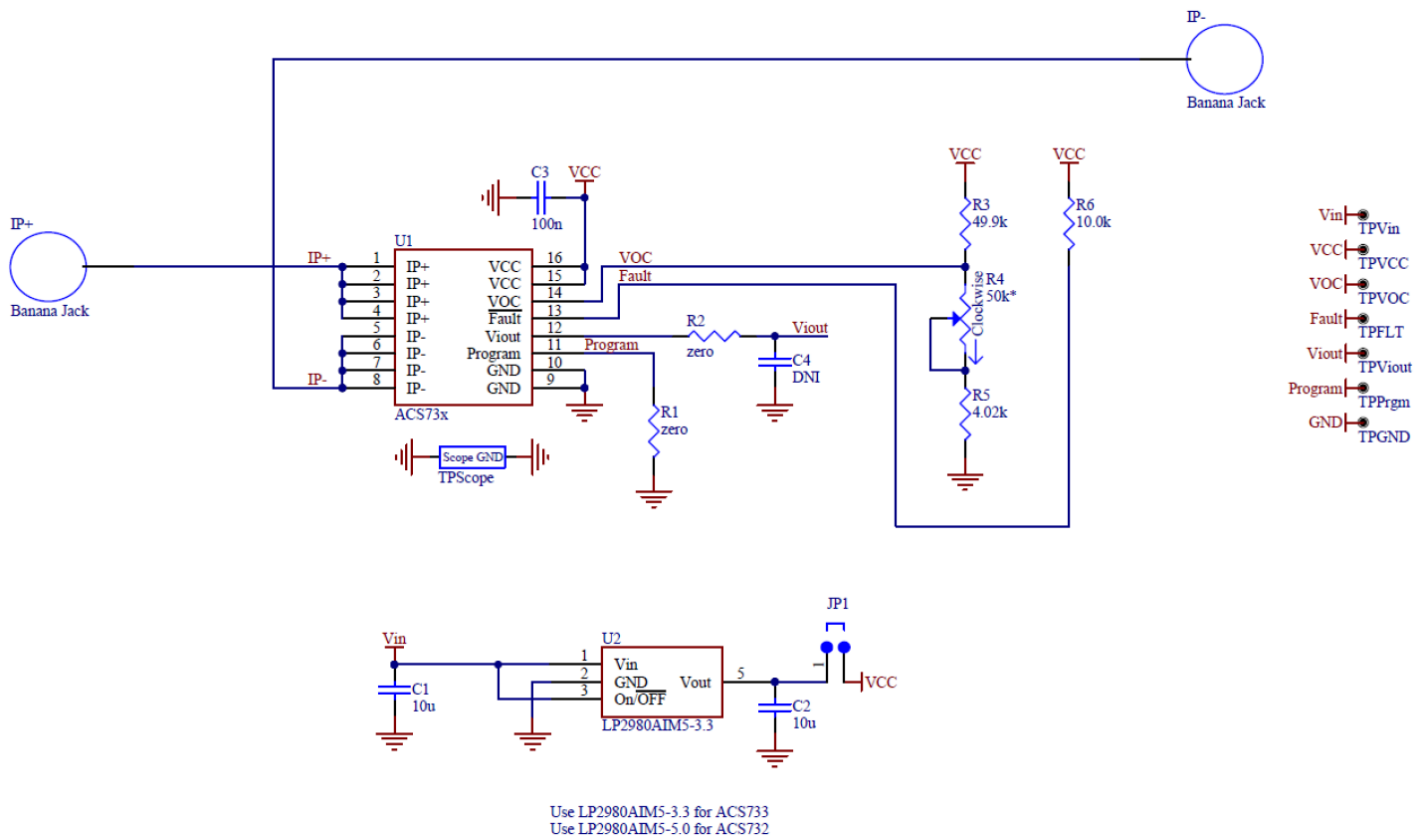
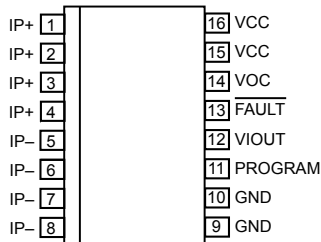

Figure 2: Schematic for ACS732 and ACS733 Demo Board

PINOUT DIAGRAM AND TERMINAL LIST

Table 2: Terminal List Table



Package LA, 16-Pin SOICW Pinout Diagram

Number	Name	Description
1,2,3,4	IP+	Positive terminals for current being sensed; fused internally.
5,6,7,8	IP-	Negative terminals for current being sensed; fused internally.
9,10	GND	Device ground terminal.
11	PROGRAM	Programming input pin for factory calibration. Connect to ground for best ESD performance.
12	VIOUT	Analog output signal.
13	FAULT	Overcurrent Fault output. Open drain.
14	VOC	Set the overcurrent fault threshold via external resistor divider on this pin.
15,16	VCC	Device power supply terminal.