



ASL5xxxHz

Matrix LED Controller (MLC)

Rev. 1.0 — 24 May 2019

Product brief

1 General description

The ASL5xxxHz family is a fully featured and flexible Matrix LED Controller (MLC). It provides a cost effective design solution, specifically targeting advanced automotive exterior lighting applications. The family consists of part numbers with different maximum currents and different driving modes, Smart and direct PWM.

Smart PWM part numbers determine PWM dimming duty cycle from information stored inside the MLC in the form of dimming polynomial curve coefficients. These coefficients are programmable by the customer according to the dimming profile they would like to see. The MLC uses these polynomial coefficients to calculate the PWM duty cycle to 12-bit resolution. The MLC also provides the capability to increase the speed of the PWM dimming curve dynamically or sequence several PWM dimming curves together.

It is possible to store polynomials for up to eight PWM dimming curves. By storing these polynomial coefficients internally, it is not necessary for the microcontroller to send updated PWM dimming information to each LED switch continuously. Instead, the microcontroller selects the PWM curve and LED to which it must be applied. Therefore, the PWM dimming information from the microcontroller is reduced, which reduces the volume of data transfer from the microcontroller to the MLC.

The MLC also provides the functionality to correct for LED brightness variations. This feature is especially useful to ensure a homogenous light output from LEDs that have luminance variations with the same LED current.

The MLC has many diagnostic features, including:

- Direct NTC feedback for monitoring the LED temperature
- Direct identification resistor input for PCB characterization
- Single LED open/short detection and protection
- Internal IC junction temperature monitoring
- Power-on-Reset (POR) monitoring; mandatory for off-board configuration and following safety requirements
- Power OK bit (POK) to ensure that the complete MLC is working as expected
- External components (NTC, ID resistor, charge pump capacitor) monitoring and fail detection
- Full communication diagnosis, including flagging illegal actions
- Possibility to clear Open Circuit (OC) and Short Circuit (SC) flags and reset the internal mosfets dynamically and without a need of a power-on-reset

All this diagnostic information is available to the microcontroller via the MLC interface. A microcontroller controls the MLC through a high-speed serial CAN interface. Through this interface, the microcontroller can control up to 32 MLCs, enabling control of up to 384 LEDs or segments.

The MLC has an internal 200 MHz oscillator that avoids the need of an external quartz (reducing system cost and providing better EMC behavior) for synchronization and clock



generation. All the internal clocks are synchronized with the internal oscillator and the trimming is done via the CAN message (CAN-ID). This process allows for a very accurate clock (accuracy < 0.25 %).

The MLC can be mounted close to the LEDs on an IMS PCB. Because the pinning has been optimized to avoid any crossing tracks, a single-layer PCB can be used. The ASL5xxxHz family is available in automotive-qualified, thermally enhanced, 36-pin HVQFN and 48-pin HLQFP packages.

The device is designed to meet the stringent requirements of automotive applications, being fully AEC Q100 grade 1 and AEC Q006 qualified. It operates over the $-40\text{ }^{\circ}\text{C}$ to $+125\text{ }^{\circ}\text{C}$ ambient temperature range.

The Matrix LED Controller (MLC) also offers the possibility to be driven in direct PWM mode. In this mode, the microcontroller needs to update the PWM value in every channel with a certain cycle, determined by the system specifications. These part numbers, ASL5115yHz and ASL5108yHz, also offer 12-bit resolution to ensure a smooth dimming performance to avoid glitches in the output light.

The MLC family also offers two different maximum currents per switch. Part numbers ASL5008yHz and ASL5108yHz offer a maximum current per switch of 0.8 A. Part numbers ASL5015yHz and ASL5115yHz offer a maximum current per switch of 1.5 A.

All part numbers are pin-to-pin compatible, which offers a completely scalable and flexible system solution that can be adapted to any system requirements.

2 Features

- Automotive grade product that is AEC-Q100 grade 1 and AEC-Q006 qualified
- Operating ambient temperature range of $-40\text{ }^{\circ}\text{C}$ to $+125\text{ }^{\circ}\text{C}$
- Maximum junction temperature of $175\text{ }^{\circ}\text{C}$
- Operating input voltage $5\text{ V} \pm 0.5\text{ V}$. Vcc pin.
- Able to drive up to 12 LEDs / segments, with a string voltage range up to 57 V
- Able to drive multiple LEDs per switch (MTP configurable)
- 12 channels, arranged in 4 configurable blocks of 3 switches per block
- Each block of three can fully float up to 60 V with respect to ground and can be paralleled with any other block
- Each switch can control up to 1.5 A LED current in the ASL5x15yHz family and up to 0.8 A in the ASL5x08yHz family
- 100 m Ω (Rdson) switches for 1.5 A part numbers and 200 m Ω for 0.8 A part numbers
- PWM dimming with 12-bit resolution and built-in phase shifting for minimum losses
- Internal PWM duty cycle generator with incremental calculation for glitch-free operation in the ASL50xxxyHz family—Smart
- On-chip storage of preprogrammed PWM curves to reduce data traffic in ASL50xxxyHz family—Smart
- LED brightness variation correction functionality
- On-chip 200 MHz oscillator, avoiding need for external quartz
- CAN-based serial interface with optional external CAN physical layer
- Broadcast messages to reduce system latency and bus load
- Low Electromagnetic Emission (EME) and high Electromagnetic Immunity (EMI)
- Individual LED open and LED short-fault monitoring, with bypass feature on open condition
- NTC input with 6-bit resolution for LED temperature monitoring; directly connected to MLC
- Identification resistor input
- MLC can be used in a configuration of up to 32 ICs in a single CAN network
- Small package outline, leadless HVQFN package with improved Automated Optical Inspection (AOI) capability and leaded HLQFP package
- Low operational current consumption
- Sleep and wake-up modes available
- Standby current consumption $< 1.35\text{ mA}$
- Input under voltage protection
- 9-bit resolution IC junction temperature feedback via CAN interface
- Internally programmed Limp Home Mode (LHM) in case of communication failure
- Built-in charge pump failure operation mode (CPFSO)

3 Applications

- Automotive lighting
 - Matrix/pixel high beam (ADB / Glare-Free High Beam - GFHB)
 - Matrix/pixel low beam (ADB)
 - Dynamic turning indicator
 - Welcoming scenarios
 - Dynamic rear lights

– Dynamic cornering lights

4 Orderable parts

Table 1. Orderable part variations

| Type number | Package | | Version |
|-------------|---------|---|-----------|
| | Name | Description | |
| ASL5015SHN | HVQFN36 | Smart internal PWM generator with prestored curves (Smart – 1.5 A) – CAN | SOT1092-4 |
| ASL5115SHN | HVQFN36 | Direct PWM data for every channel (Direct – 1.5 A) – CAN | SOT1092-4 |
| ASL5008SHN | HVQFN36 | Smart internal PWM generator with prestored curves (Smart – 0.8 A) – CAN | SOT1092-4 |
| ASL5108SHN | HVQFN36 | Direct PWM data for every channel (Direct – 0.8 A) – CAN | SOT1092-4 |
| ASL5015FHN | HVQFN36 | Smart internal PWM generator with prestored curves (Smart – 1.5 A) – CAN-FD | SOT1092-4 |
| ASL5115FHN | HVQFN36 | Direct PWM data for every channel (Direct – 1.5 A) – CAN-FD | SOT1092-4 |
| ASL5008FHN | HVQFN36 | Smart internal PWM generator with prestored curves (Smart – 0.8 A) – CAN-FD | SOT1092-4 |
| ASL5108FHN | HVQFN36 | Direct PWM data for every channel (Direct – 0.8 A) – CAN-FD | SOT1092-4 |
| ASL5015SHV | HLQFP48 | Smart internal PWM generator with prestored curves (Smart – 1.5 A) – CAN | SOT1571-1 |
| ASL5115SHV | HLQFP48 | Direct PWM data for every channel (Direct – 1.5 A) – CAN | SOT1571-1 |
| ASL5008SHV | HLQFP48 | Smart internal PWM generator with prestored curves (Smart – 0.8 A) – CAN | SOT1571-1 |
| ASL5108SHV | HLQFP48 | Direct PWM data for every channel (Direct – 0.8 A) – CAN | SOT1571-1 |
| ASL5015FHV | HLQFP48 | Smart internal PWM generator with prestored curves (Smart – 1.5 A) – CAN-FD | SOT1571-1 |
| ASL5115FHV | HLQFP48 | Direct PWM data for every channel (Direct – 1.5 A) – CAN-FD | SOT1571-1 |
| ASL5008FHV | HLQFP48 | Smart internal PWM generator with prestored curves (Smart – 0.8 A) – CAN-FD | SOT1571-1 |
| ASL5108FHV | HLQFP48 | Direct PWM data for every channel (Direct – 0.8 A) – CAN-FD | SOT1571-1 |

5 Application diagram

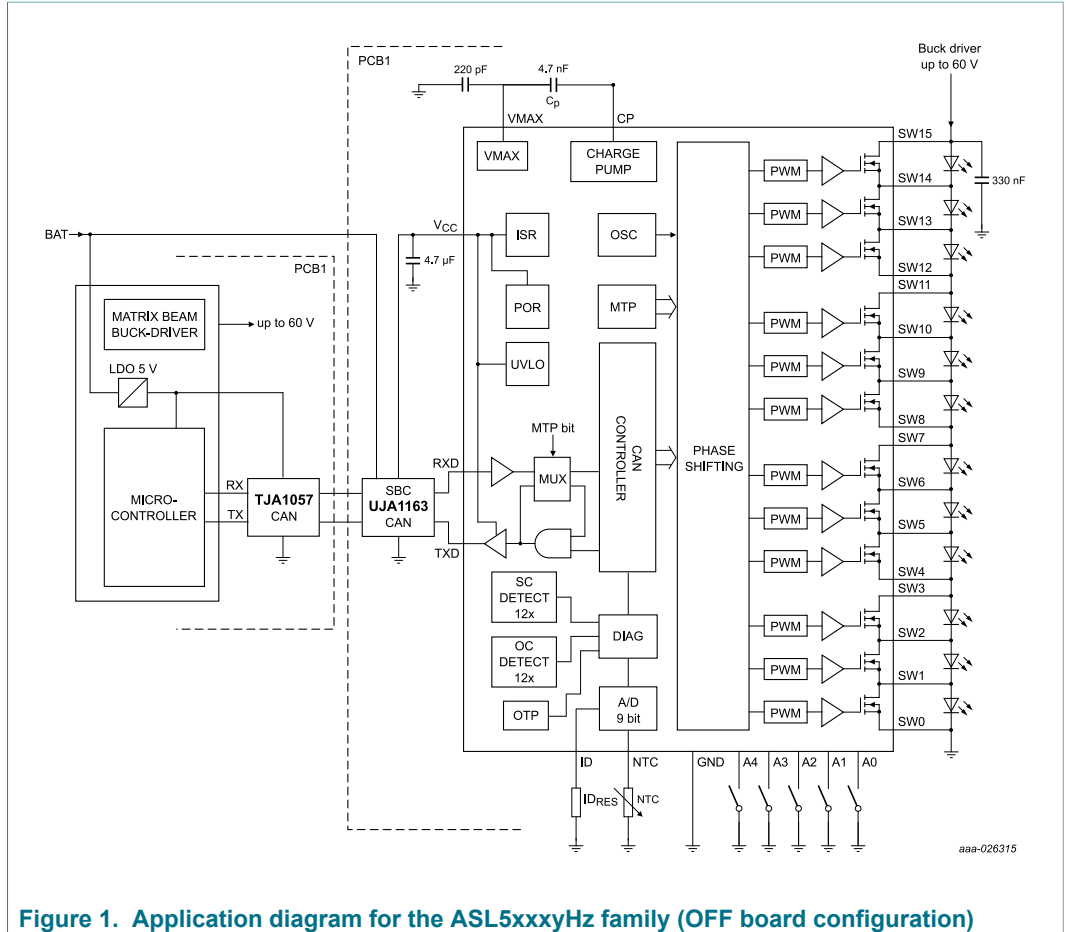

6 Packaging

6.1 Package mechanical dimensions

Package dimensions are provided in package drawings. To find the most current package outline drawing, go to www.nxp.com and perform a keyword search for the drawing's document number.

Table 2. Package Outline

| Package | Package outline drawing number |
|--------------|--------------------------------|
| 36-pin HVQFN | SOT1092-4 |
| 48-pin HLQFP | SOT1571-1 |

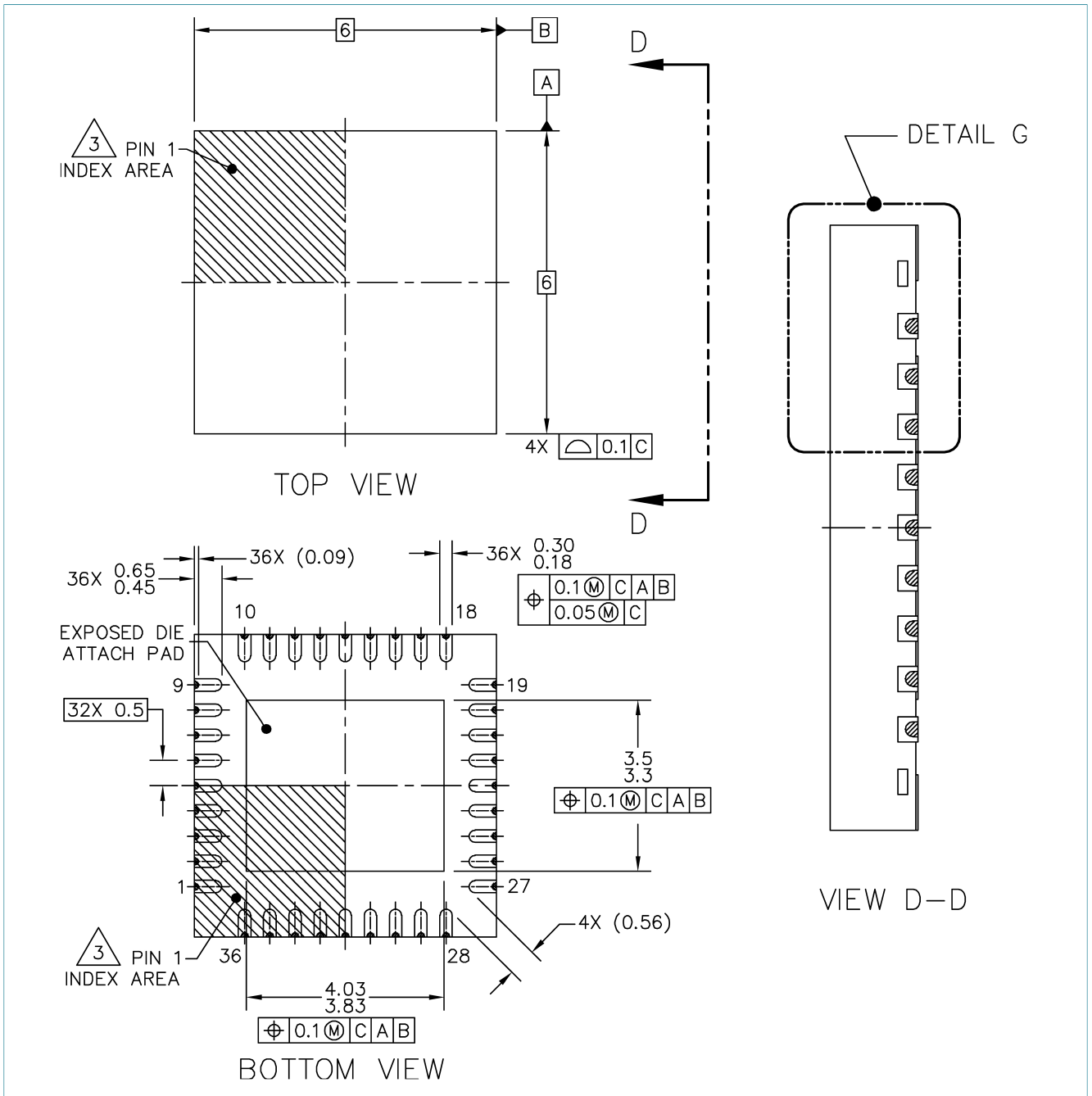

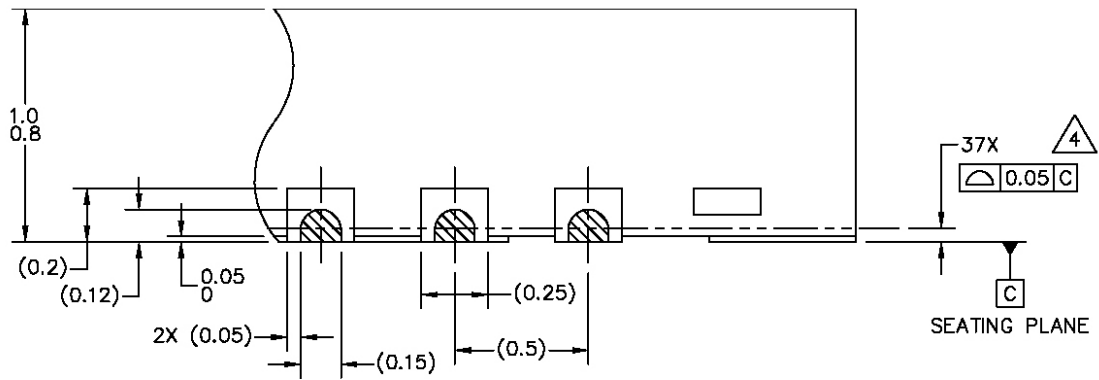

DETAIL G
VIEW ROTATED 90° CW

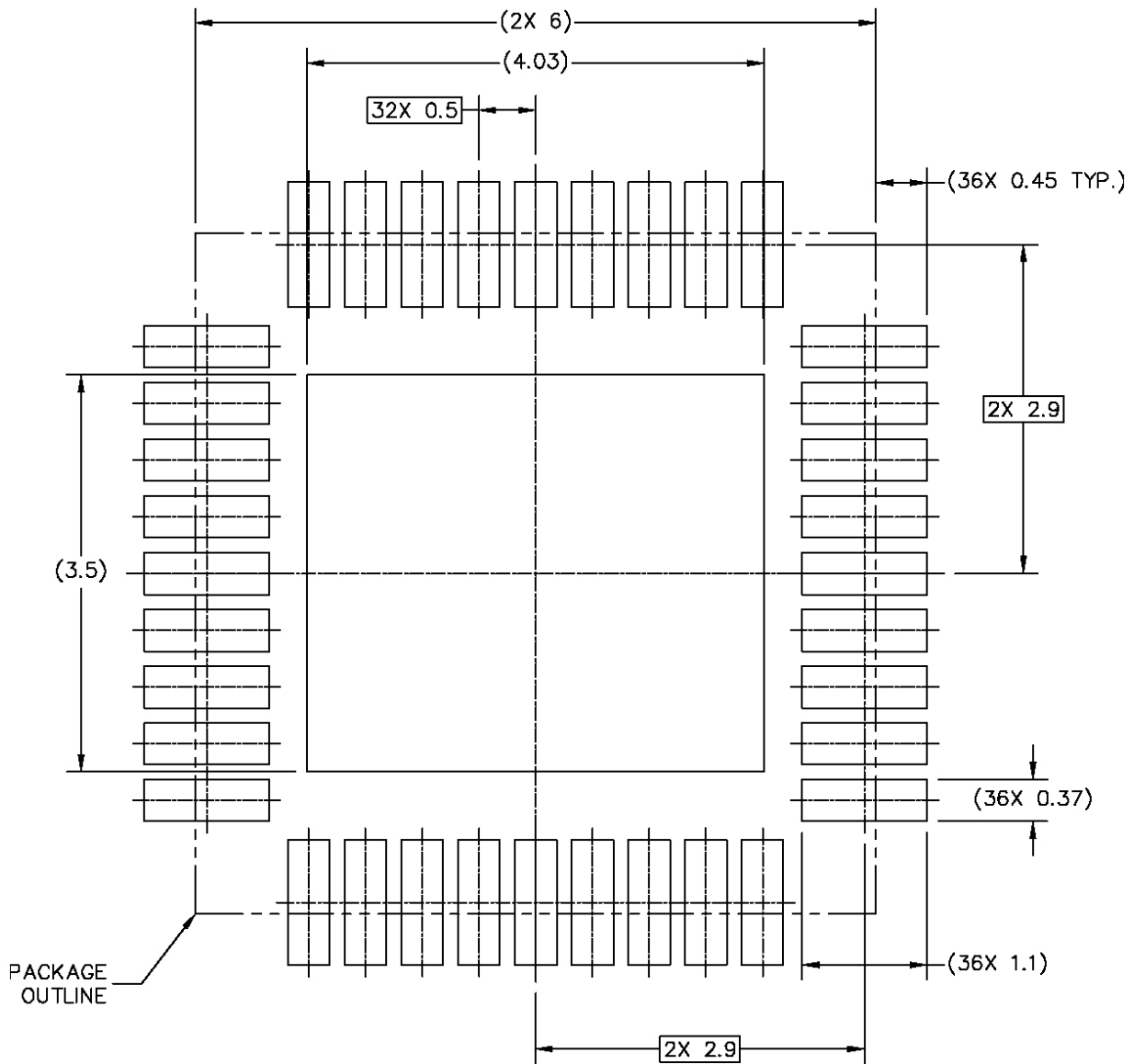

PCB DESIGN GUIDELINES – SOLDER MASK OPENING PATTERN

THIS SHEET SERVES ONLY AS A GUIDELINE TO HELP DEVELOP A USER SPECIFIC SOLUTION. DEVELOPMENT EFFORT WILL STILL BE REQUIRED BY END USERS TO OPTIMIZE PCB MOUNTING PROCESSES AND BOARD DESIGN IN ORDER TO MEET INDIVIDUAL/SPECIFIC REQUIREMENTS.

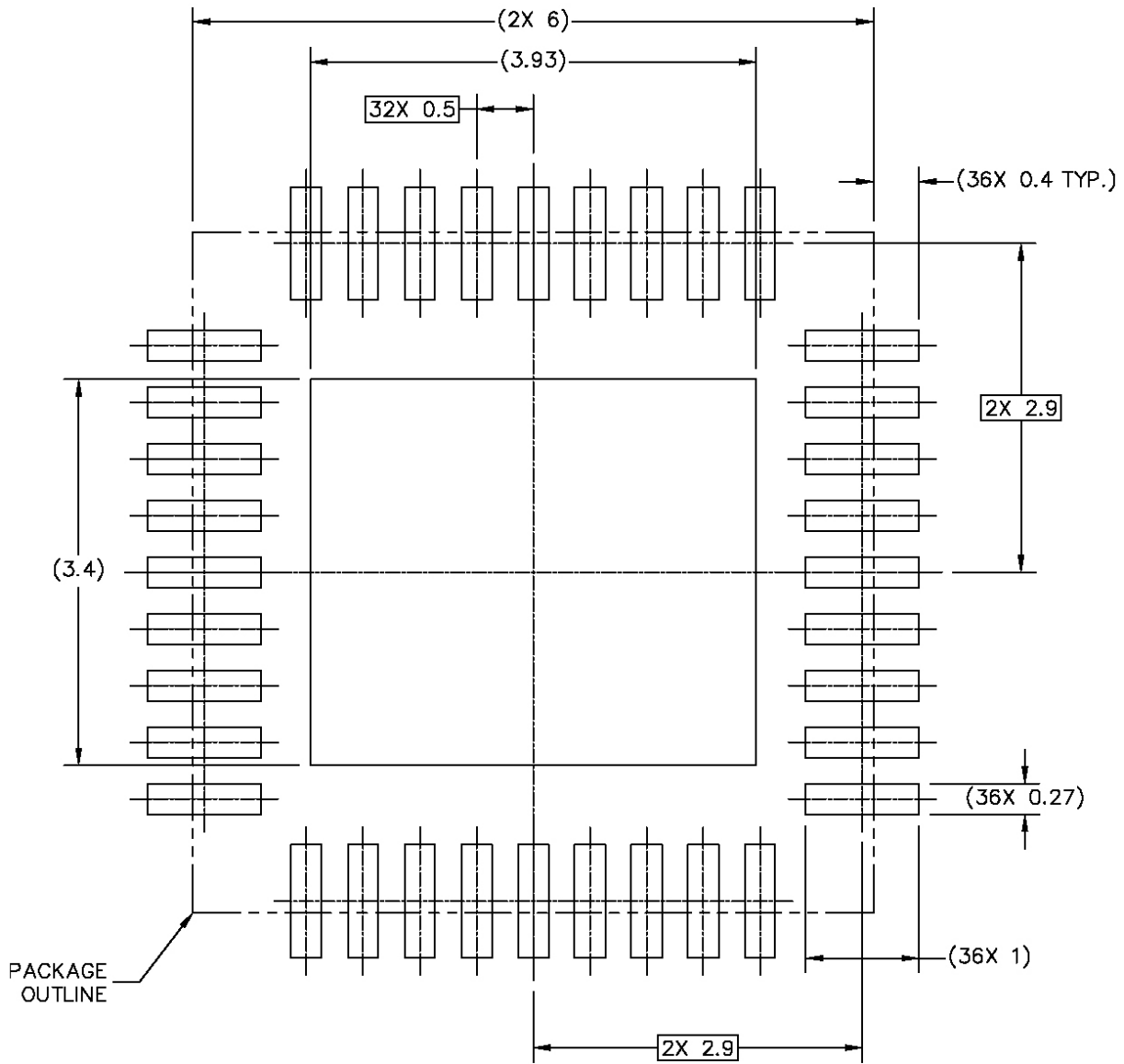

PCB DESIGN GUIDELINES – I/O PADS AND SOLDERABLE AREA

THIS SHEET SERVES ONLY AS A GUIDELINE TO HELP DEVELOP A USER SPECIFIC SOLUTION. DEVELOPMENT EFFORT WILL STILL BE REQUIRED BY END USERS TO OPTIMIZE PCB MOUNTING PROCESSES AND BOARD DESIGN IN ORDER TO MEET INDIVIDUAL/SPECIFIC REQUIREMENTS.

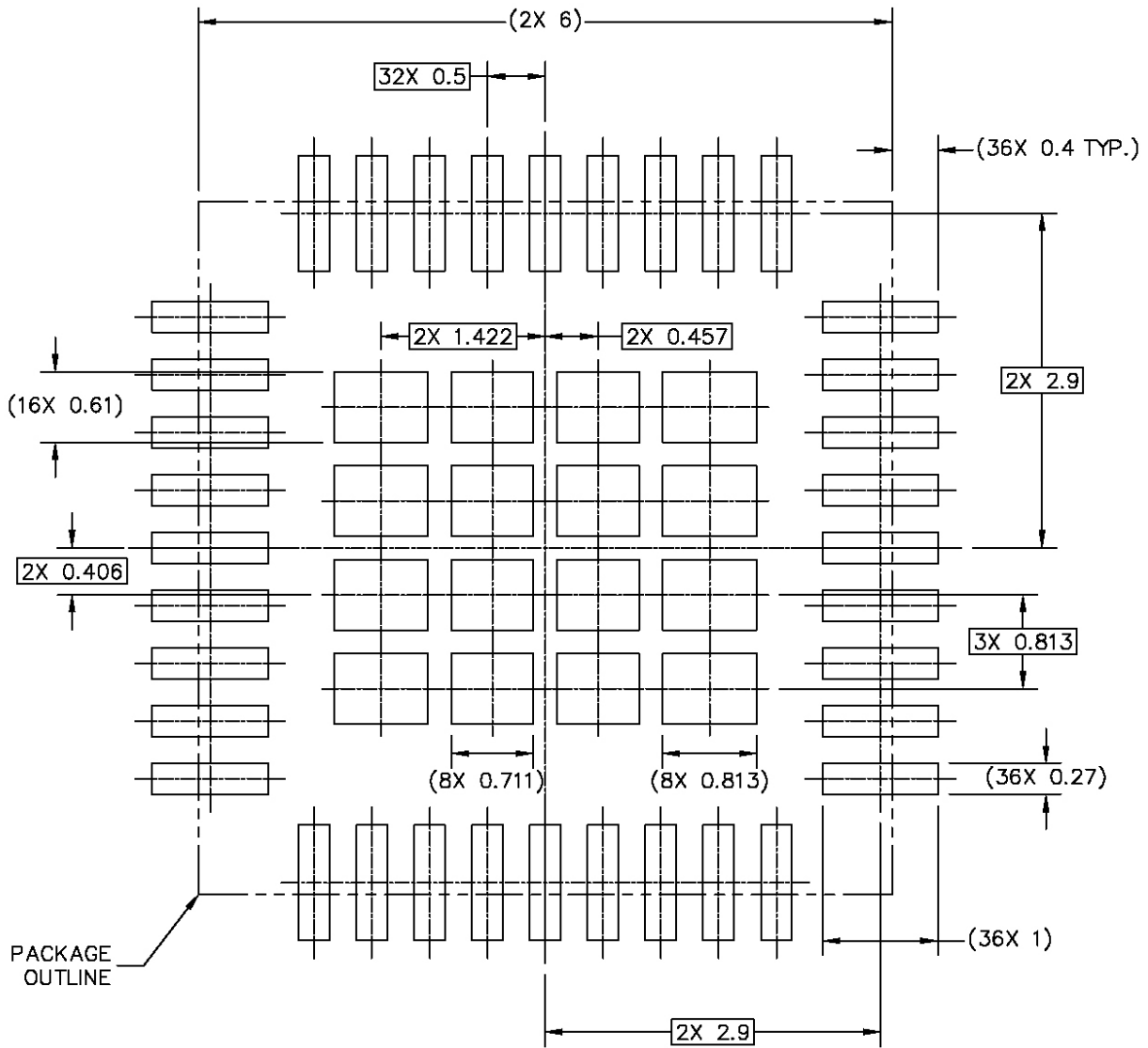

RECOMMENDED STENCIL THICKNESS 0.125

PCB DESIGN GUIDELINES – SOLDER PASTE STENCIL

THIS SHEET SERVES ONLY AS A GUIDELINE TO HELP DEVELOP A USER SPECIFIC SOLUTION. DEVELOPMENT EFFORT WILL STILL BE REQUIRED BY END USERS TO OPTIMIZE PCB MOUNTING PROCESSES AND BOARD DESIGN IN ORDER TO MEET INDIVIDUAL/SPECIFIC REQUIREMENTS.

Figure 2. Package outline – HVQFN package

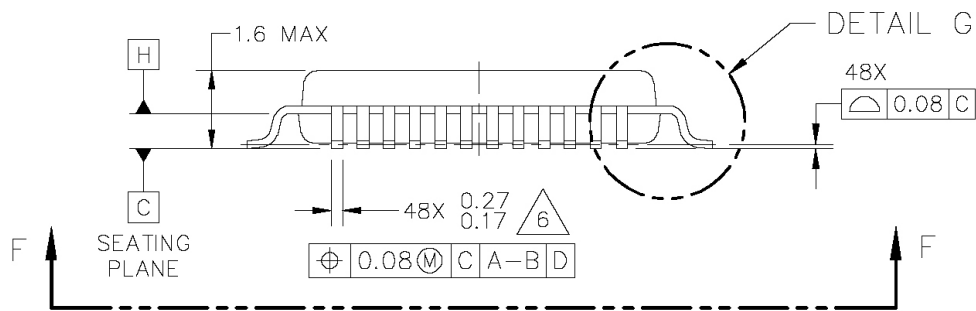
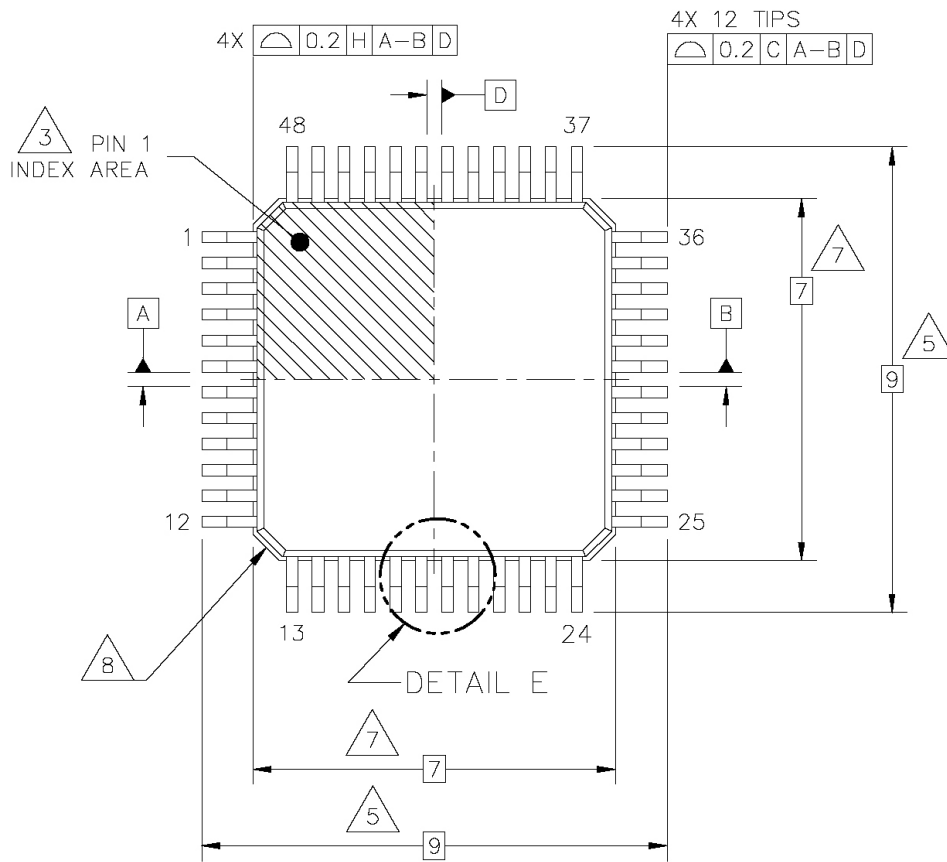

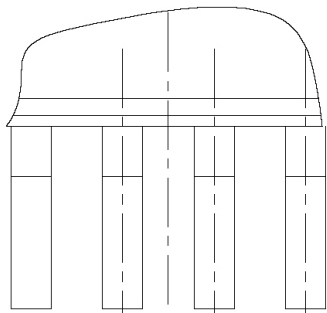

44X 0.5
 0.25
 X X=A, B OR D

DETAIL E
 4X

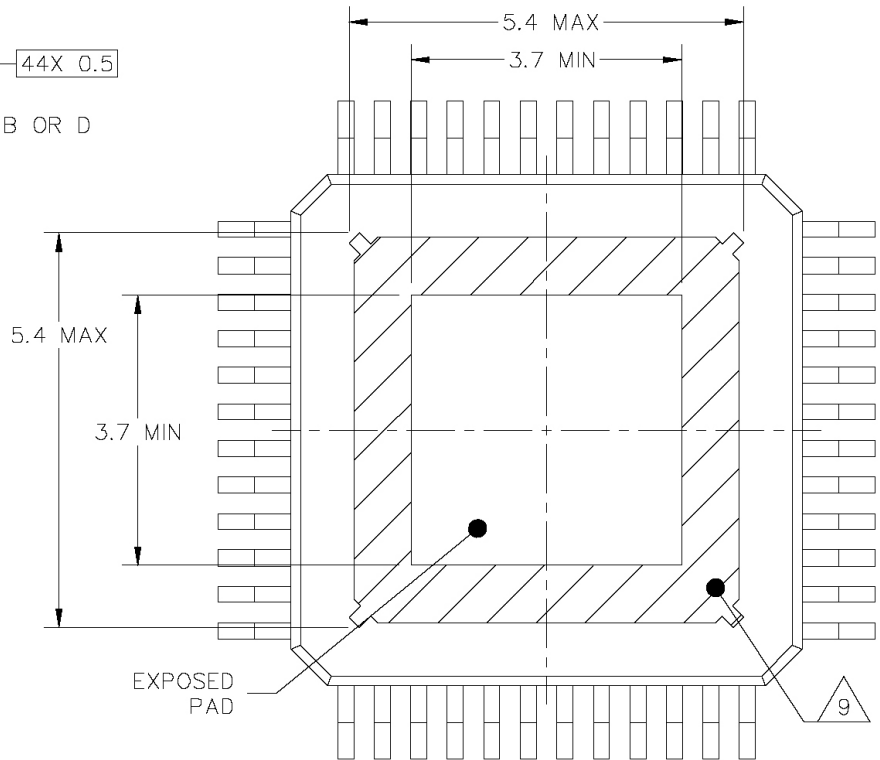

VIEW G-G

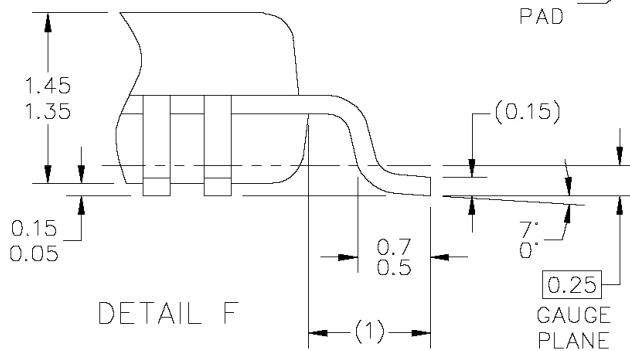

DETAIL F

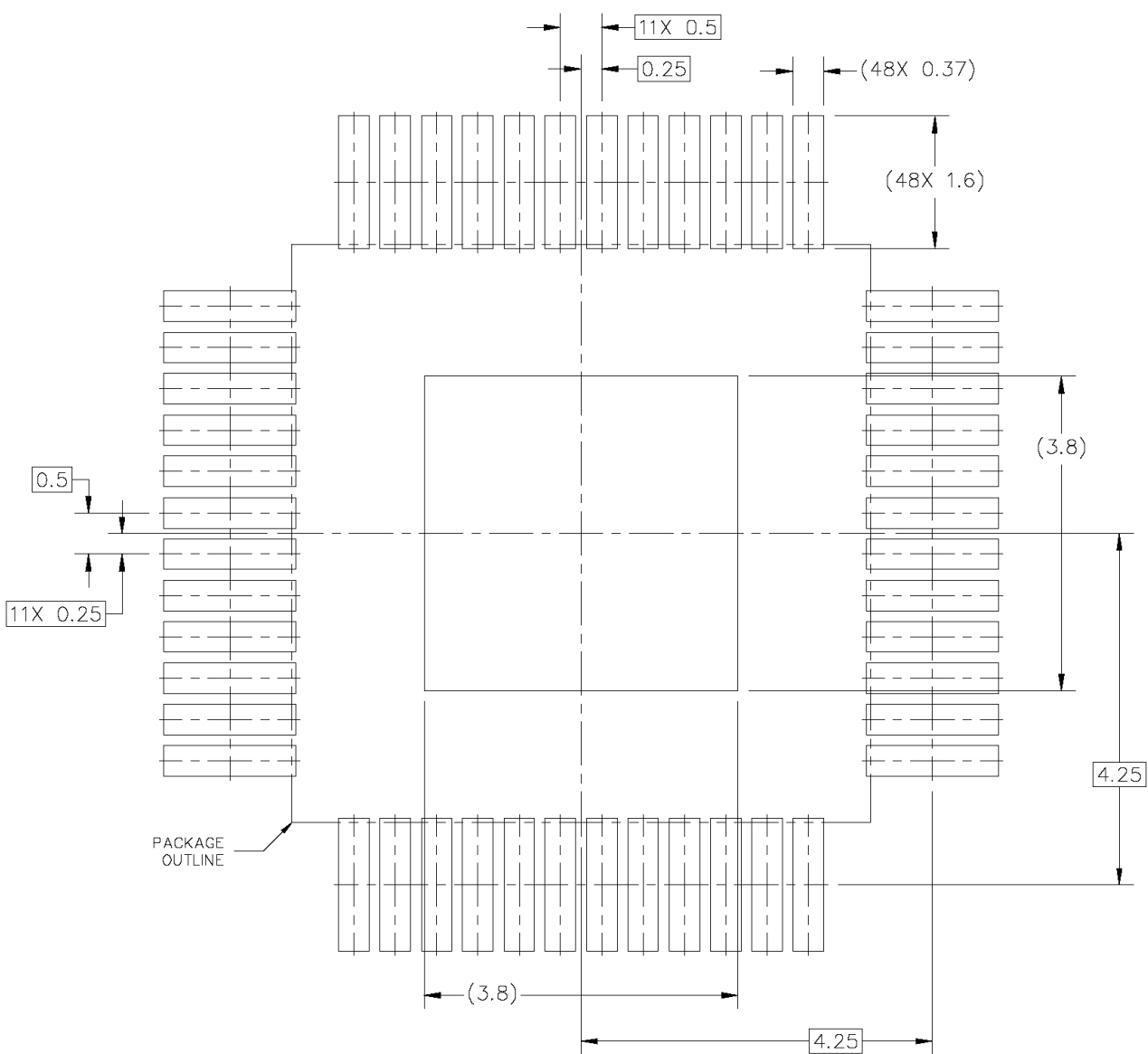

PCB DESIGN GUIDELINES – SOLDER MASK OPENING PATTERN

THIS SHEET SERVES ONLY AS A GUIDELINE TO HELP DEVELOP A USER SPECIFIC SOLUTION. DEVELOPMENT EFFORT WILL STILL BE REQUIRED BY END USERS TO OPTIMIZE PCB MOUNTING PROCESSES AND BOARD DESIGN IN ORDER TO MEET INDIVIDUAL/SPECIFIC REQUIREMENTS.

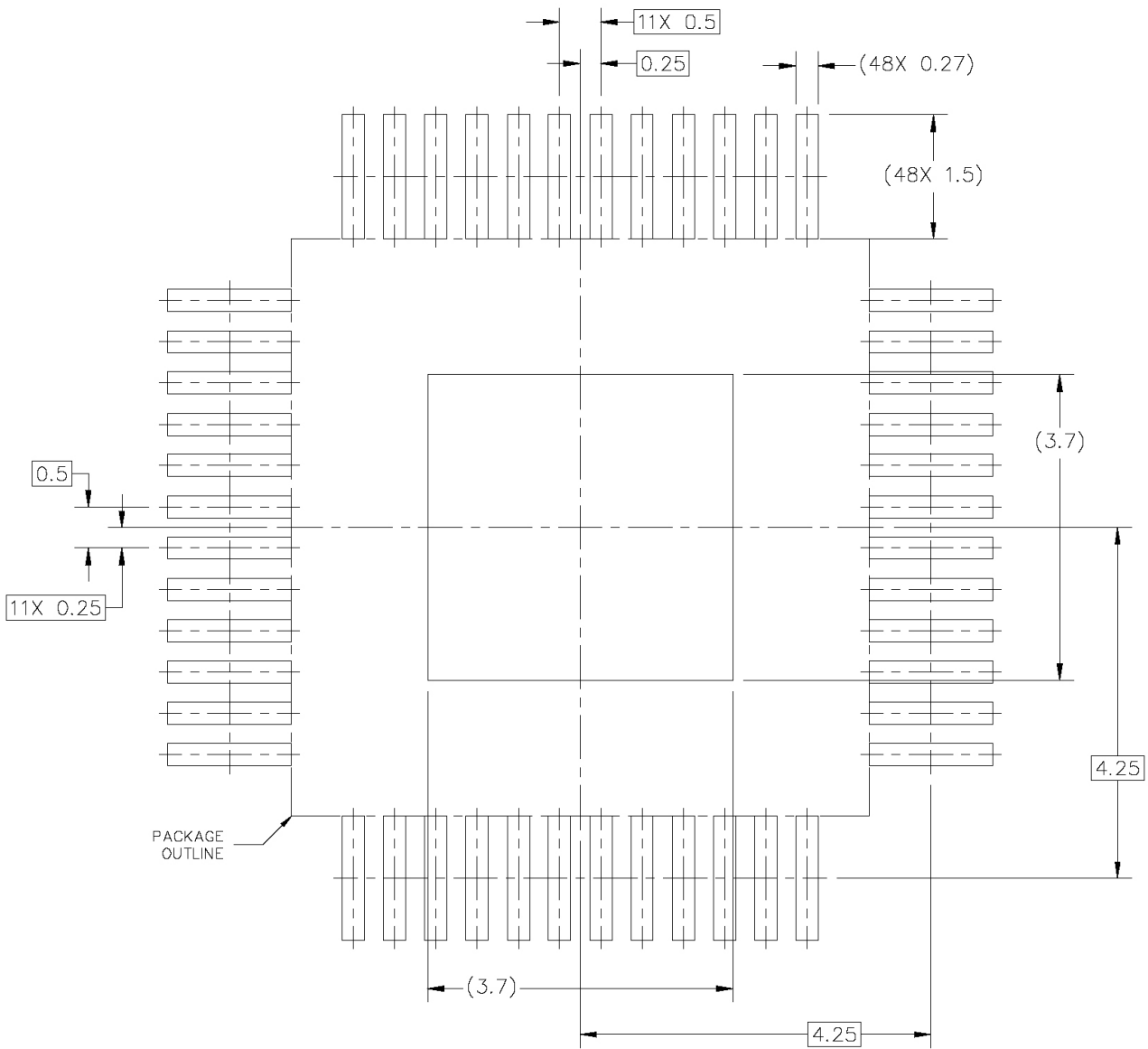

PCB DESIGN GUIDELINES – I/O PADS AND SOLDERABLE AREA

THIS SHEET SERVES ONLY AS A GUIDELINE TO HELP DEVELOP A USER SPECIFIC SOLUTION. DEVELOPMENT EFFORT WILL STILL BE REQUIRED BY END USERS TO OPTIMIZE PCB MOUNTING PROCESSES AND BOARD DESIGN IN ORDER TO MEET INDIVIDUAL/SPECIFIC REQUIREMENTS.

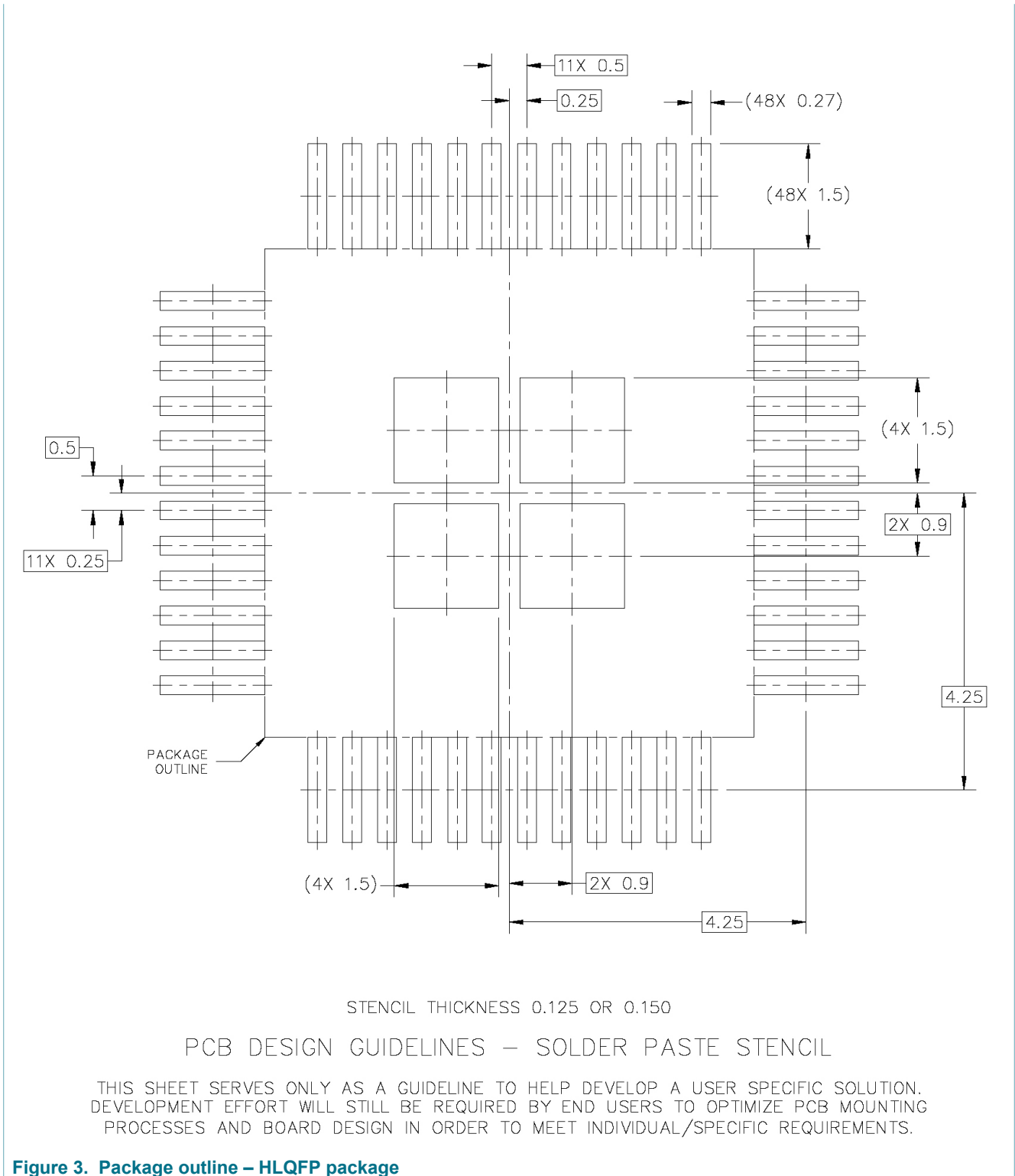

Figure 3. Package outline – HLQFP package

7 Legal information

7.1 Definitions

Draft — The document is a draft version only. The content is still under internal review and subject to formal approval, which may result in modifications or additions. NXP Semiconductors does not give any representations or warranties as to the accuracy or completeness of information included herein and shall have no liability for the consequences of use of such information.

7.2 Disclaimers

Limited warranty and liability — Information in this document is believed to be accurate and reliable. However, NXP Semiconductors does not give any representations or warranties, expressed or implied, as to the accuracy or completeness of such information and shall have no liability for the consequences of use of such information. NXP Semiconductors takes no responsibility for the content in this document if provided by an information source outside of NXP Semiconductors. In no event shall NXP Semiconductors be liable for any indirect, incidental, punitive, special or consequential damages (including - without limitation - lost profits, lost savings, business interruption, costs related to the removal or replacement of any products or rework charges) whether or not such damages are based on tort (including negligence), warranty, breach of contract or any other legal theory. Notwithstanding any damages that customer might incur for any reason whatsoever, NXP Semiconductors' aggregate and cumulative liability towards customer for the products described herein shall be limited in accordance with the Terms and conditions of commercial sale of NXP Semiconductors.

Right to make changes — NXP Semiconductors reserves the right to make changes to information published in this document, including without limitation specifications and product descriptions, at any time and without notice. This document supersedes and replaces all information supplied prior to the publication hereof.

Applications — Applications that are described herein for any of these products are for illustrative purposes only. NXP Semiconductors makes no representation or warranty that such applications will be suitable for the specified use without further testing or modification. Customers are responsible for the design and operation of their applications and products using NXP Semiconductors products, and NXP Semiconductors accepts no liability for any assistance with applications or customer product design. It is customer's sole responsibility to determine whether the NXP Semiconductors product is suitable and fit for the customer's applications and products planned, as well as for the planned application and use of customer's third party customer(s). Customers should provide appropriate design and operating safeguards to minimize the risks associated with their applications and products. NXP Semiconductors does not accept any liability related to any default, damage, costs or problem which is based on any weakness or default in the customer's applications or products, or the application or use by customer's third party customer(s). Customer is

responsible for doing all necessary testing for the customer's applications and products using NXP Semiconductors products in order to avoid a default of the applications and the products or of the application or use by customer's third party customer(s). NXP does not accept any liability in this respect.

Limiting values — Stress above one or more limiting values (as defined in the Absolute Maximum Ratings System of IEC 60134) will cause permanent damage to the device. Limiting values are stress ratings only and (proper) operation of the device at these or any other conditions above those given in the Recommended operating conditions section (if present) or the Characteristics sections of this document is not warranted. Constant or repeated exposure to limiting values will permanently and irreversibly affect the quality and reliability of the device.

Terms and conditions of commercial sale — NXP Semiconductors products are sold subject to the general terms and conditions of commercial sale, as published at <http://www.nxp.com/profile/terms>, unless otherwise agreed in a valid written individual agreement. In case an individual agreement is concluded only the terms and conditions of the respective agreement shall apply. NXP Semiconductors hereby expressly objects to applying the customer's general terms and conditions with regard to the purchase of NXP Semiconductors products by customer.

No offer to sell or license — Nothing in this document may be interpreted or construed as an offer to sell products that is open for acceptance or the grant, conveyance or implication of any license under any copyrights, patents or other industrial or intellectual property rights.

Suitability for use in automotive applications — This NXP Semiconductors product has been qualified for use in automotive applications. Unless otherwise agreed in writing, the product is not designed, authorized or warranted to be suitable for use in life support, life-critical or safety-critical systems or equipment, nor in applications where failure or malfunction of an NXP Semiconductors product can reasonably be expected to result in personal injury, death or severe property or environmental damage. NXP Semiconductors and its suppliers accept no liability for inclusion and/or use of NXP Semiconductors products in such equipment or applications and therefore such inclusion and/or use is at the customer's own risk.

Export control — This document as well as the item(s) described herein may be subject to export control regulations. Export might require a prior authorization from competent authorities.

Translations — A non-English (translated) version of a document is for reference only. The English version shall prevail in case of any discrepancy between the translated and English versions.

7.3 Trademarks

Notice: All referenced brands, product names, service names and trademarks are the property of their respective owners.

Tables

| | | | |
|---|---|-------------------------------|---|
| Tab. 1. Orderable part variations | 4 | Tab. 2. Package Outline | 5 |
|---|---|-------------------------------|---|

Figures

| | | | |
|---|---|---|----|
| Fig. 1. Application diagram for the ASL5xxxyHz family (OFF board configuration) | 5 | Fig. 2. Package outline – HVQFN package | 6 |
| | | Fig. 3. Package outline – HLQFP package | 11 |