

# SPECIFICATIONS

| PARAMETERS              | VALUES           | UNITS |
|-------------------------|------------------|-------|
| RATED VOLTAGE           | 10               | Vp-p  |
| OPERATING VOLTAGE RANGE | 1 ~ 30           | Vp-p  |
| RATED CURRENT (MAX)     | 8                | mA    |
| CAPACITANCE             | 12,000 ± 30%     | pF    |
| MINIMUM SPL @ 10 CM     | 85               | dBA   |
| RESONANT FREQUENCY      | 6,000 ± 500      | Hz    |
| OPERATING TEMPERATURE   | -30 ~ +85        | °C    |
| STORAGE TEMPERATURE     | -40 ~ +95        | °C    |
| HOUSING MATERIAL        | UL94 ABS         | -     |
| TERMINAL MATERIAL       | Sn PLATED BRONZE | -     |
| WEIGHT                  | 2.3              | grams |

THIS DOCUMENT CONTAINS DATA PROPRIETARY TO PROJECTS UNLIMITED, INC. ANY USE OR REPRODUCTION, IN ANY FORM, WITHOUT PRIOR WRITTEN PERMISSION OF PROJECTS UNLIMITED, INC. IS PROHIBITED.  
©2003, Projects Unlimited Inc.

# REVISION HISTORY

| LTR | DESCRIPTION                              | DATE      | APPROVED |
|-----|--|-----------|----------|
| -   | RELEASED FROM ENGINEERING                | 2/27/2006 |          |
| A   | REVISED PIN DIAMETER                     | 9/2/2008  | B.R.     |
| B   | REVISED TO INVENTOR 3-D DRAWING TEMPLATE | 9/12/2008 | B.R.     |
| C   | REVISED WEIGHT AND PIN DIAMETER          | 2/27/2020 | M.V.     |

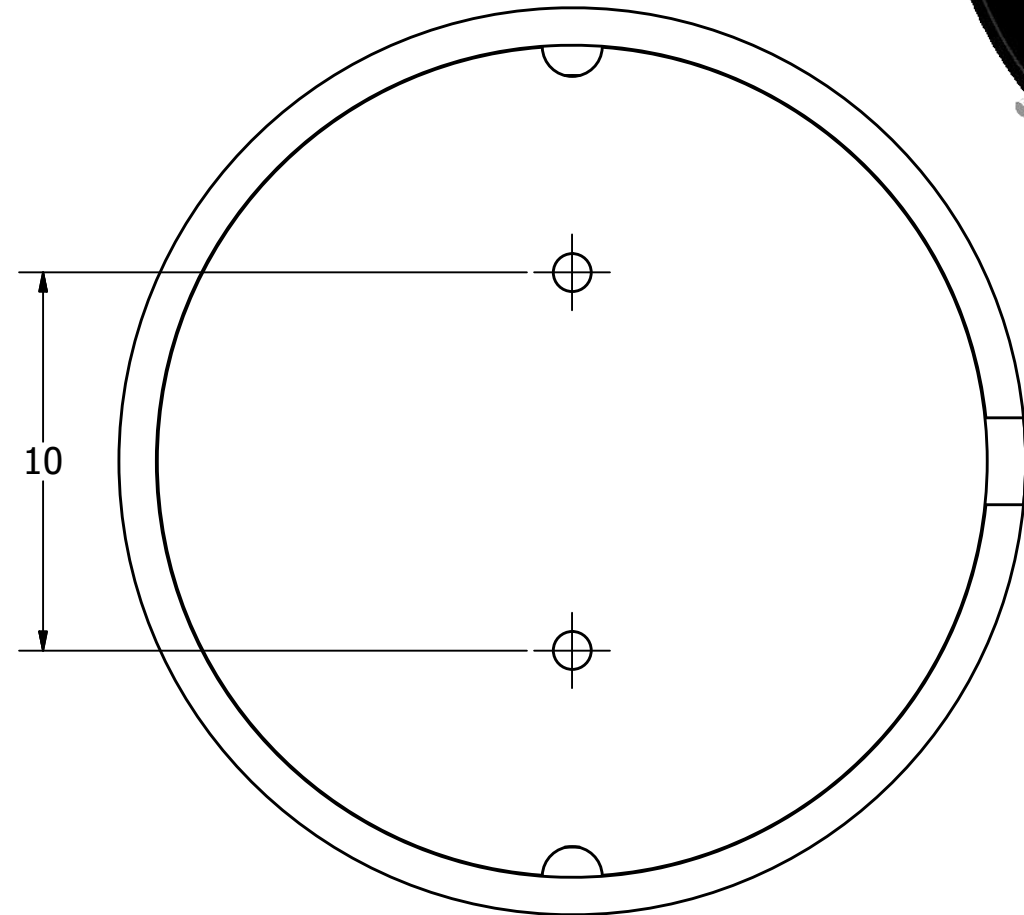
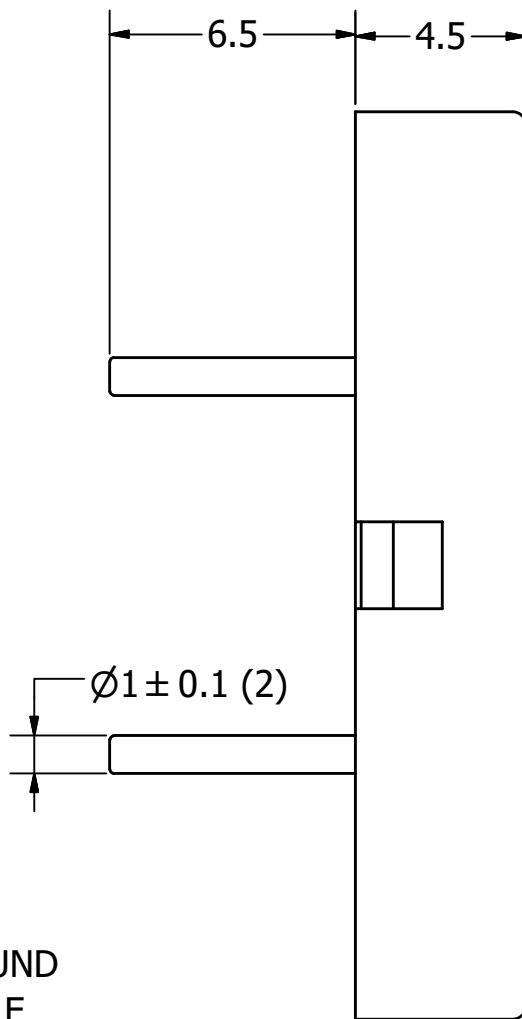
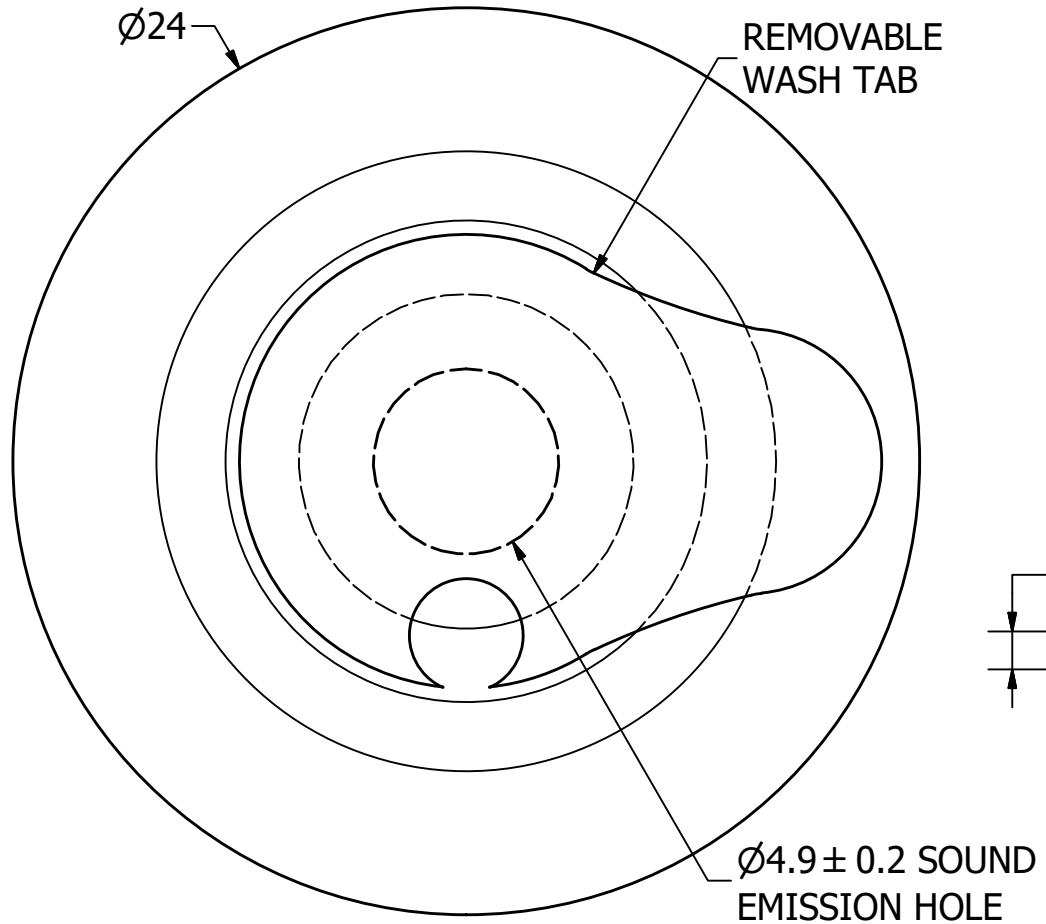

### NOTES:

1. ALL DIMENSIONS ARE IN MILLIMETERS.
2. SPECIFICATIONS SUBJECT TO CHANGE OR WITHDRAWL WITHOUT NOTICE.
3. THIS PART IS RoHS 2002/95/EC COMPLIANT.

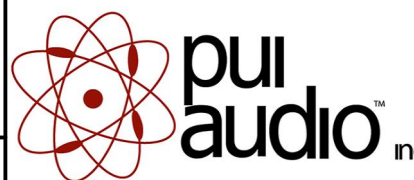
|  |                   |   |           |                      |          |             |                    |            |
|--|-------------------|---|-----------|----------------------|----------|-------------|--------------------|------------|
| UNLESS OTHERWISE SPECIFIED:<br>DIMENSIONS ARE IN MILLIMETERS,<br>TOLERANCES ARE ±0.5 AND ANGLES ARE ±3°. | SIZE<br><b>A3</b> | Designed by   | Date      | Checked by           | Date     | Approved by | Date               | Drawn Date |
|  |                   | J.A.F.  | 2/27/2006 | B.R.                 | 3/1/2006 | E.P.        | 3/1/2006           | 9/12/2008  |
| AT-2460-TWT-R.idw  |                   |  |           | <b>AT-2460-TWT-R</b> |          |             | Transducer (Piezo) |            |
|  |                   |   |           |                      |          |             | Edition            | Sheet      |
|  |                   |   |           |                      |          |             | -                  | 1 / 1      |