

Features

- Attenuation: 1 dB steps to 31 dB
- Temperature Stability:
±0.18 dB from -55°C to +85°C
- Low DC Power Consumption
- Hermetic Surface Mount Package
- Integral TTL Driver
- 50 Ω Nominal Impedance
- Lead-Free CR-12 Package
- Halogen-Free “Green” Mold Compound
- RoHS* Compliant and 260°C Reflow Compatible

Description

The AT-263-PIN is a GaAs FET 5-bit digital attenuator with a 1 dB minimum step size and 31 dB total attenuation. This attenuator and integral TTL driver is in a hermetically sealed ceramic 16-lead surface mount package.

The AT-263-PIN is ideally suited for use where accuracy, fast switching, very low power consumption and low intermodulation products are required. Typical applications include dynamic range setting in precision receiver circuits and other gain/leveling control circuits.

Environmental screening is available. Contact the factory for information.

Ordering Information¹

Part Number	Package
AT-263-PIN	Bulk Packaging
AT-263TR	1000 piece reel
AT-263-TB	Sample Test Board

1. Reference Application Note M513 for reel size information.

Functional Schematic

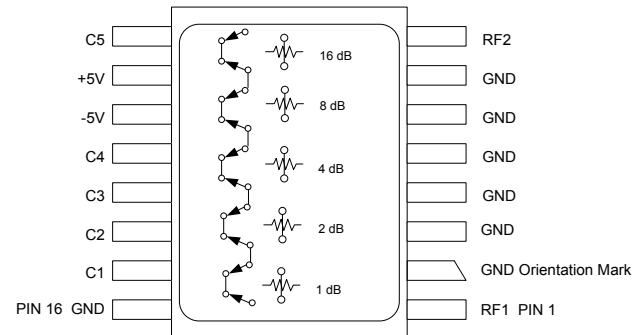

Pin Configuration²

Pin No.	Function	Pin No.	Function
1	RF1	9	C5
2	GND	10	+5V
3	GND	11	-5V
4	GND	12	C4
5	GND	13	C3
6	GND	14	C2
7	GND	15	C1
8	RF2	16	GND

2. The exposed pad centered on the package bottom must be connected to RF, DC and thermal ground.

* Restrictions on Hazardous Substances, European Union Directive 2011/65/EU.

Electrical Specifications^{3,4}: -55°C to +85°C

Parameter	Test Conditions	Units	Min.	Typ.	Max.
Insertion Loss	DC - 0.5 GHz	dB	—	—	2.4
	DC - 1.0 GHz				2.8
	DC - 2.0 GHz				3.0
Attenuation Accuracy	Any single bits DC - 1.0 GHz	dB	±(0.25 +3% of atten setting)		
	Any combination of bits DC - 2.0 GHz		±(0.25 +3% of atten setting) or ±0.4 whichever is greater		
VSWR	Insertion Loss, DC - 2.0 GHz Attenuation States, DC - 2.0 GHz	Ratio	—	—	1.6:1 1.8:1
Switching Speed	50% Control to 90%/10% RF 10% to 90% or 90% to 10%	ns	—	40 9	—
Transients	In-Band (peak-peak)	mV	—	30	—
1 dB Compression	0.05 GHz	dBm	—	20	—
	0.5 - 2.0 GHz			28	
Input IP3	Two-tone inputs up to +5 dBm	dBm	—	40	—
	0.05 GHz 0.5 - 2.0 GHz			48	
Input IP2	Two-tone inputs up to +5 dBm	dBm	—	45	—
	0.05 GHz 0.5 - 2.0 GHz			68	
V _{CC}	—	V	+4.5	+5.0	+5.5
V _{EE}	—	V	-8.0	—	-5.0
I _{CC}	V _{CC} = 4.5 to 5.5 V V _{CONTROL} = 0 to 0.8 V, or V _{CC} -2.1 V to V _{CC}	mA	—	—	5.0
I _{EE}	V _{EE} = -5 to -8 V	mA	—	—	1.0
Voltage Control	Logic 0 (TTL)	V	0.0	—	0.8
	Logic 1 (TTL)		2.0		5.0
Input Leakage Current	0 to 0.8 V 2 to 5 V	μA	—	—	1.0

3. All specifications apply when operated with bias voltages of +5 V for V_{CC} and -5 V for V_{EE}.

4. This attenuator is guaranteed monotonic.

Absolute Maximum Ratings^{5,6}

Parameter	Absolute Maximum
Input Power 0.05 GHz 0.5 - 2.0 GHz	27 dBm 34 dBm
V_{CC}	$-0.5 V \leq V_{CC} \leq +7.0 V$
V_{EE}	$-8.5 V \leq V_{EE} \leq +0.5 V$
$V_{CC} - V_{EE}$	$-0.5 V \leq V_{CC} - V_{EE} \leq 14.5 V$
V_{IN} ⁷	$-0.5 V \leq V_{IN} \leq V_{CC} + 0.5 V$
Operating Temperature	$-55^{\circ}C$ to $+125^{\circ}C$
Storage Temperature	$-65^{\circ}C$ to $+150^{\circ}C$

- Exceeding any one or combination of these limits may cause permanent damage to this device.
- MACOM does not recommend sustained operation near these survivability limits.
- Standard CMOS TTL interface, latch-up will occur if logic signal is applied prior to power supply.

Truth Table⁸

Control Inputs					
C5	C4	C3	C2	C1	Attenuation
0	0	0	0	0	Reference
0	0	0	0	1	1 dB
0	0	0	1	0	2 dB
0	0	1	0	0	4 dB
0	1	0	0	0	8 dB
1	0	0	0	0	16 dB
1	1	1	1	1	31 dB

8. 0 = TTL Low; 1 = TTL High

Handling Procedures

Please observe the following precautions to avoid damage:

Static Sensitivity

These electronic devices are sensitive to electrostatic discharge (ESD) and can be damaged by static electricity. Proper ESD control techniques should be used when handling these devices.

Recommended PCB Configuration

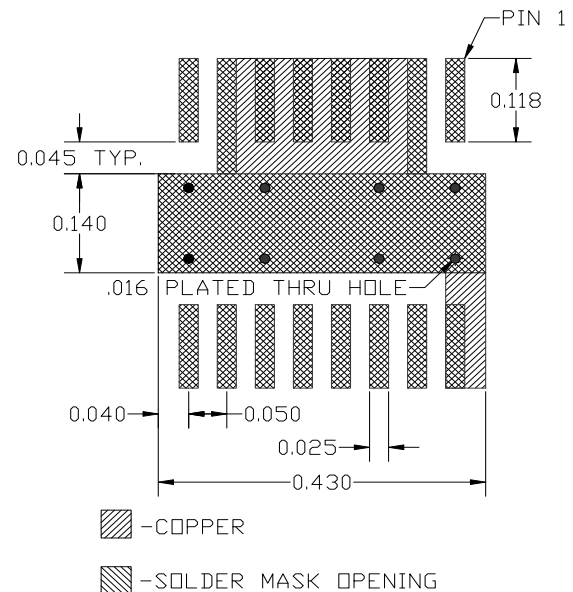

TYPICAL METAL/SOLDER MASK LAYOUT FOR CR-12 PACKAGE

Typical Performance Curves

Ref. Insertion Loss vs. Frequency

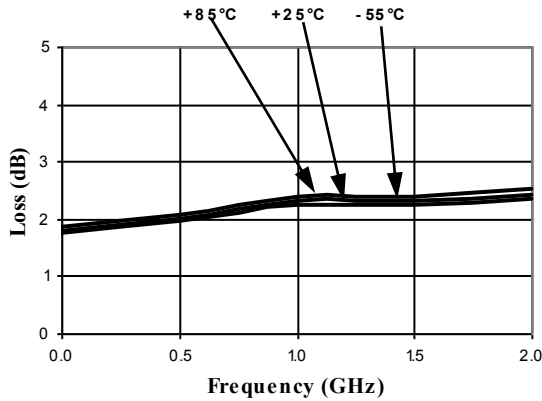

Attenuation Accuracy vs. Frequency

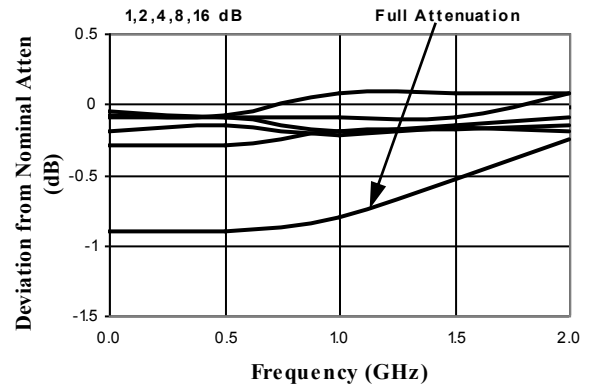

VSWR vs. Frequency

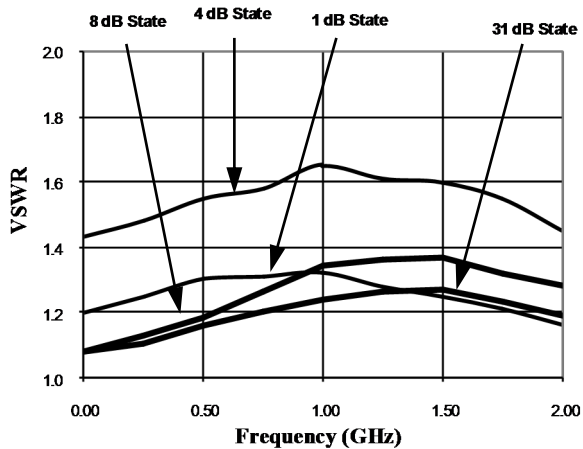

Lead-Free, CR-12 Ceramic Package†

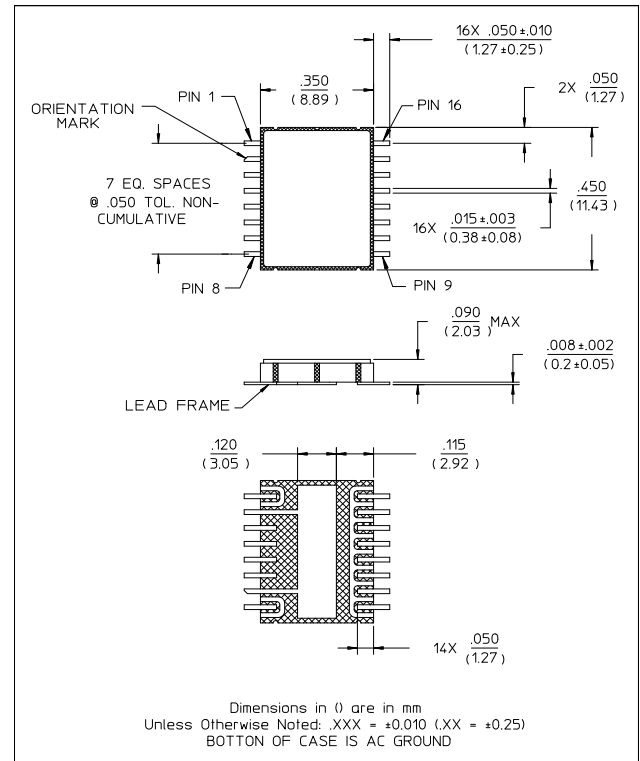

† Reference Application Note M538 for lead-free solder reflow recommendations.