

GaAs Digital Attenuator 31 dB, 5 - Bit, DC - 2 GHz

Rev. V4

Features

- n Attenuation 1 dB Steps to 31 dB
- n TTL Control Interface
- n Hermetic Connectorized Housing

Description

C-46

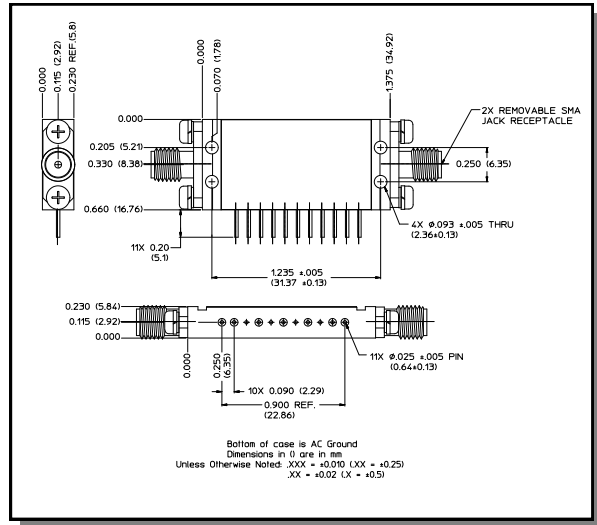

Electrical Specifications ¹: T_A = -55°C to +85°C

Parameter	Test Conditions	Frequency	Units	Min	Typ	Max
Nominal Attenuation ²	1 dB Steps to 31 dB					
Attenuation Accuracy		DC - 1.0 GHz 1.0 - 2.0 GHz		± (0.2 dB +2% of Atten Setting in dB) dB ± (0.2 dB +2% of Atten Setting in dB) dB		
VSWR		DC - .025 GHz .025 - 0.5 GHz 0.2 - 2.0 GHz 0.5 - 1.0 GHz	Ratio Ratio Ratio Ratio	— — — —	— — — —	2.2:1 1.8:1 1.5:1 1.4:1
Reference Insertion Loss		DC - 0.5 GHz 0.5 - 1.0 GHz 1.0 - 2.0 GHz	dB dB dB	— — —	— — —	5.5 6.0 6.5
Impedance	—	—	Ohms	—	50	—
T _{on} T _{off}	50% CTL to 90% RF 50% CTL to 10% RF	— —	ns ns	— —	160 80	— —
T _{rise} T _{fall}	10% RF to 90% RF 90% RF to 10% RF	— —	ns ns	— —	15 3	— —
Transients	Unfiltered	—	mV	—	130	—
1 dB Compression	Input Power	0.5 - 2.0 GHz 0.05 GHz	dBm dBm	— —	28 15	— —
IP2	Two-Tone Input Power up to +5 dBm	0.5 - 2.0 GHz 0.05 GHz	dBm dBm	— —	+55 +45	— —
IP3	Two-Tone Input Power up to +5 dBm	0.5 - 2.0 GHz 0.05 GHz	dBm dBm	— —	+47 +28	— —

Electrical Specifications ¹: T_A = -55°C to +85°C

Parameter	Test Conditions	Frequency	Units	Min	Typ	Max
Bias Power	+15 VDC	—	mA	—	—	5
	-12 VDC	—	mA	—	—	3
Vin Low (0)	0.0 to 0.8V	—	μA	—	—	1
Vin High (1)	2.4 to 5.0V	—	μA	—	—	1

Functional Schematic (Top View)

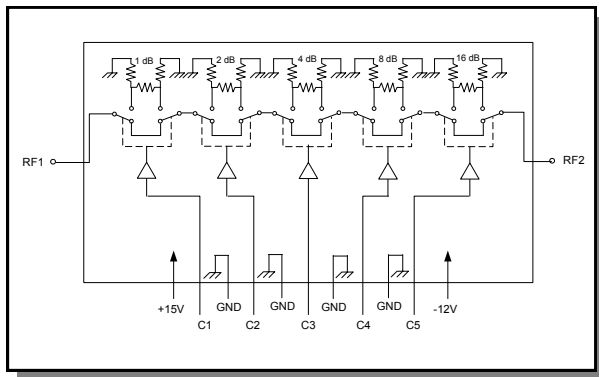

Truth Table

Control Input					Attenuation Setting
C1	C2	C3	C4	C5	
0	0	0	0	0	Reference
1	0	0	0	0	1 dB
0	1	0	0	0	2 dB
0	0	1	0	0	4 dB
0	0	0	1	0	8 dB
0	0	0	0	1	16 dB
Any Combination					Sum of Bits Selected

Absolute Maximum Ratings ⁴

Parameter	Absolute Maximum
Max Input Power 0.05 GHz 0.5 - 2.0 GHz	+27 dBm +32 dBm
Bias Voltage +15V Supply (V+) -12V Supply (V-)	-0.7V to +18V -15V to +0.7V
Control Voltage	(V-) -2V to (V+) +2V (or 30 mA, whichever comes first)
Operating Temperature	-55°C to +125°C
Storage Temperature	-65°C to +150°C

"1" = Logic High (TTL)

"0" = Logic Low (TTL)

4. Operation of this device above any one of these parameters may cause permanent damage.

Typical Performance Curves

Attenuation Flatness vs. Frequency

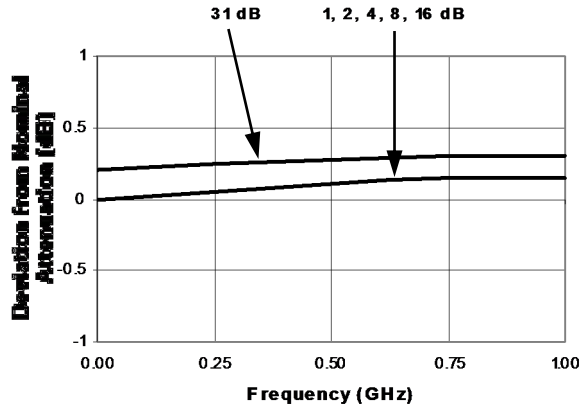

Ref. Insertion Loss vs. Frequency

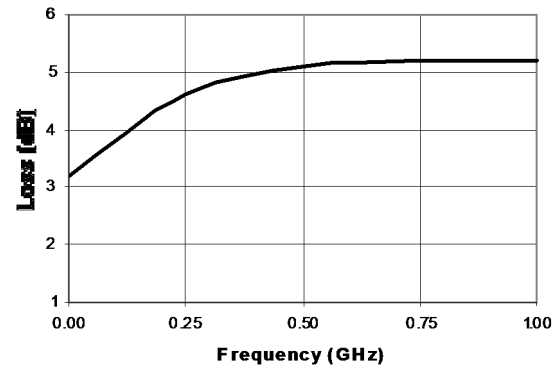

VSWR vs. Frequency

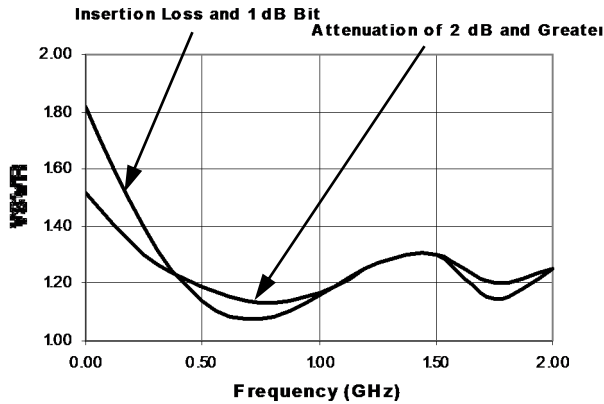

Ordering Information

Part Number	Package
AT-357 SMA	C-46