

Digital Attenuator 31.0 dB, 5-Bit, TTL Driver, DC-2.0 GHz

Rev. V5

Features

- Attenuation: 1 dB steps to 31 dB
- Temperature Stability: ± 0.18 dB from -40°C to $+85^{\circ}\text{C}$ Typical
- Low DC Power Consumption
- Surface Mount Package
- Integral TTL Driver
- Low Cost/High Performance
- 50 Ohm Nominal Impedance
- Lead-Free CR-12 Package
- 260°C Reflow Compatible
- RoHS* Compliant

Description

M/A-COM's AT20-0263 is a GaAs FET 5-bit digital attenuator with a 1 dB minimum step size and 31 dB total attenuation. This attenuator and integral TTL driver is in a ceramic 16-lead surface mount package. The AT20-0263 is ideally suited for use where accuracy, fast switching, very low power consumption and low intermodulation products are required. Typical applications include dynamic range setting in precision receiver circuits and other gain/leveling control circuits. Available with enhanced performance as fully hermetic version. Environmentally screenable as P/N AT-263-PIN.

Functional Schematic

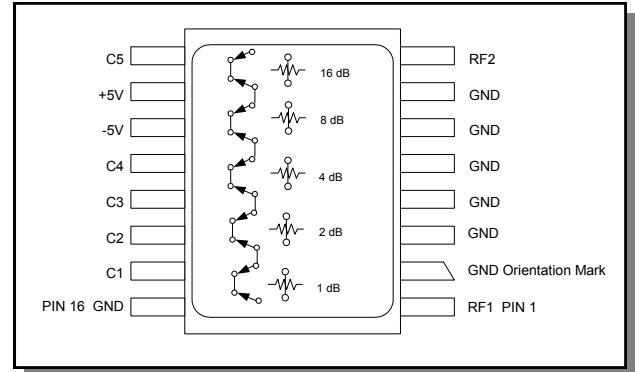

Pin Configuration

Pin No.	Function	Pin No.	Function
1	RF1	9	C5
2	GND	10	+5V
3	GND	11	-5V
4	GND	12	C4
5	GND	13	C3
6	GND	14	C2
7	GND	15	C1
8	RF2	16	GND

The metal bottom of the case must be connected to RF and DC ground.

Ordering Information

Part Number	Package
AT20-0263	Bulk Packaging

Note: Reference Application Note M513 for reel size information.

* Restrictions on Hazardous Substances, European Union Directive 2002/95/EC.

Digital Attenuator 31.0 dB, 5-Bit, TTL Driver, DC-2.0 GHz

Rev. V5

Electrical Specifications: $T_A = 25^\circ\text{C}^1$

Parameter	Test Conditions	Frequency	Units	Min	Typ	Max
Reference Insertion Loss	—	DC - 0.5 GHz DC - 1.0 GHz DC - 2.0 GHz	dB dB dB	— — —	2.0 2.2 2.5	2.4 2.8 3.0
Attenuation Accuracy ²	Any Single Bit Any Combination of Bits	DC - 1.0 GHz DC - 2.0 GHz	± (0.25 +3% of atten setting in dB) dB ± (0.25 +3% of atten setting in dB) dB or ± 0.4 dB, whichever is greater			
VSWR	—	DC - 2.0 GHz	Ratio	—	—	1.6:1
Trise, Tfall	10% to 90%	—	ns	—	50	—
Ton, Toff	50% Control to 90/10% RF	—	ns	—	150	—
Transients	In-Band (peak-peak)	—	mV	—	50	—
1 dB Compression	Input Power Input Power	0.05 GHz 0.5 - 2.0 GHz	dBm dBm	— —	+20 +28	— —
Input IP3	For two-tone Input Power Up to +5 dBm	0.05 GHz 0.5 - 2.0 GHz	dBm dBm	— —	+40 +48	— —
Input IP2	For two-tone Input Power Up to +5 dBm	0.05 GHz 0.5 - 2.0 GHz	dBm dBm	— —	+45 +68	— —
Vcc	—	—	V	4.5	5.0	5.5
Vee	—	—	V	-8.0	—	-5.0
Icc	Vcc = 4.5 to 5.5V Vctl = 0 to 0.8V, or Vcc - 2.1V to Vcc	—	mA	—	—	5.0
Iee	Vee = -5.0 to -8.0V	—	mA	—	—	1.0

- All specifications apply when operated with bias voltages of +5V for Vcc and -5.0V for Vee.
- This attenuator is guaranteed monotonic.

Absolute Maximum Ratings ^{3,4}

Parameter	Absolute Maximum
Max Input Power 0.5 GHz 0.5 - 2.0 GHz	+27 dBm +34 dBm
V _{CC}	-0.5V ≤ V _{CC} ≤ +7.0V
V _{EE}	-8.5V ≤ V _{EE} ≤ +0.5V
V _{CC} - V _{EE}	-0.5V ≤ V _{CC} - V _{EE} ≤ 14.5V
V _{in} ⁵	-0.5V ≤ V _{in} ≤ V _{CC} + 0.5V
Operating Temperature	-40°C to +125°C
Storage Temperature	-65°C to +150°C

- Exceeding any one or combination of these limits may cause permanent damage to this device.
- M/A-COM does not recommend sustained operation near these survivability limits.
- Standard CMOS TTL interface, latch-up will occur if logic signal is applied prior to power supply.

Recommended PCB Configuration

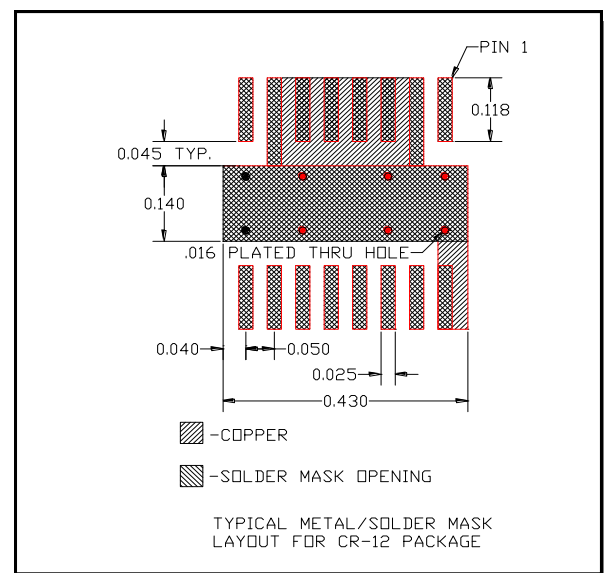

M/A-COM Technology Solutions Inc. (MACOM) and its affiliates reserve the right to make changes to the product(s) or information contained herein without notice. Visit www.macom.com for additional data sheets and product information.

Handling Procedures

Please observe the following precautions to avoid damage:

Static Sensitivity

Gallium Arsenide Integrated Circuits are sensitive to electrostatic discharge (ESD) and can be damaged by static electricity. Proper ESD control techniques should be used when handling these devices.

Truth Table (Digital Attenuator)

Control Inputs					Attenuation
C5	C4	C3	C2	C1	
0	0	0	0	0	Reference
0	0	0	0	1	1 dB
0	0	0	1	0	2 dB
0	0	1	0	0	4 dB
0	1	0	0	0	8 dB
1	0	0	0	0	16 dB
1	1	1	1	1	31 dB

0 = TTL Low; 1 = TTL High

Typical Performance Curves

Ref. Insertion Loss vs. Frequency

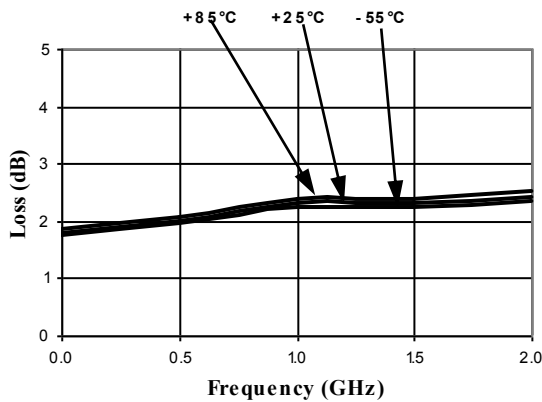

Attenuation Accuracy vs. Frequency

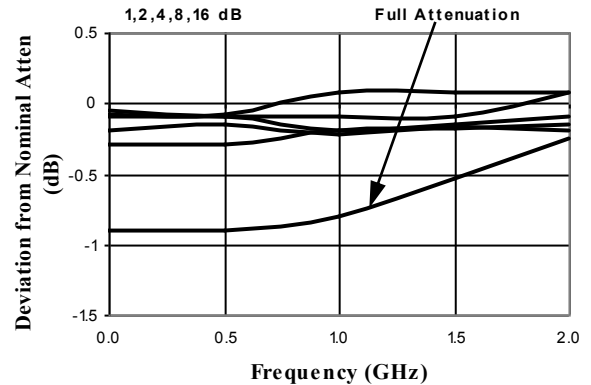

VSWR vs. Frequency

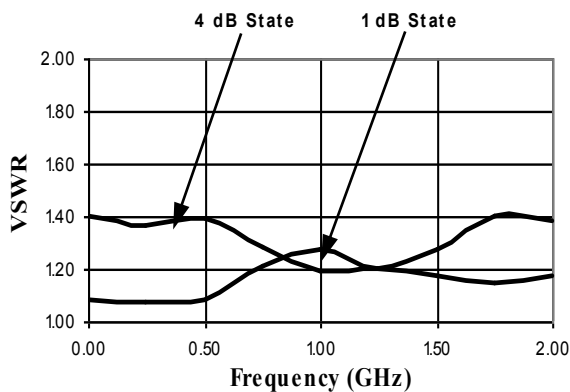

Lead-Free CR-12 Ceramic Package†

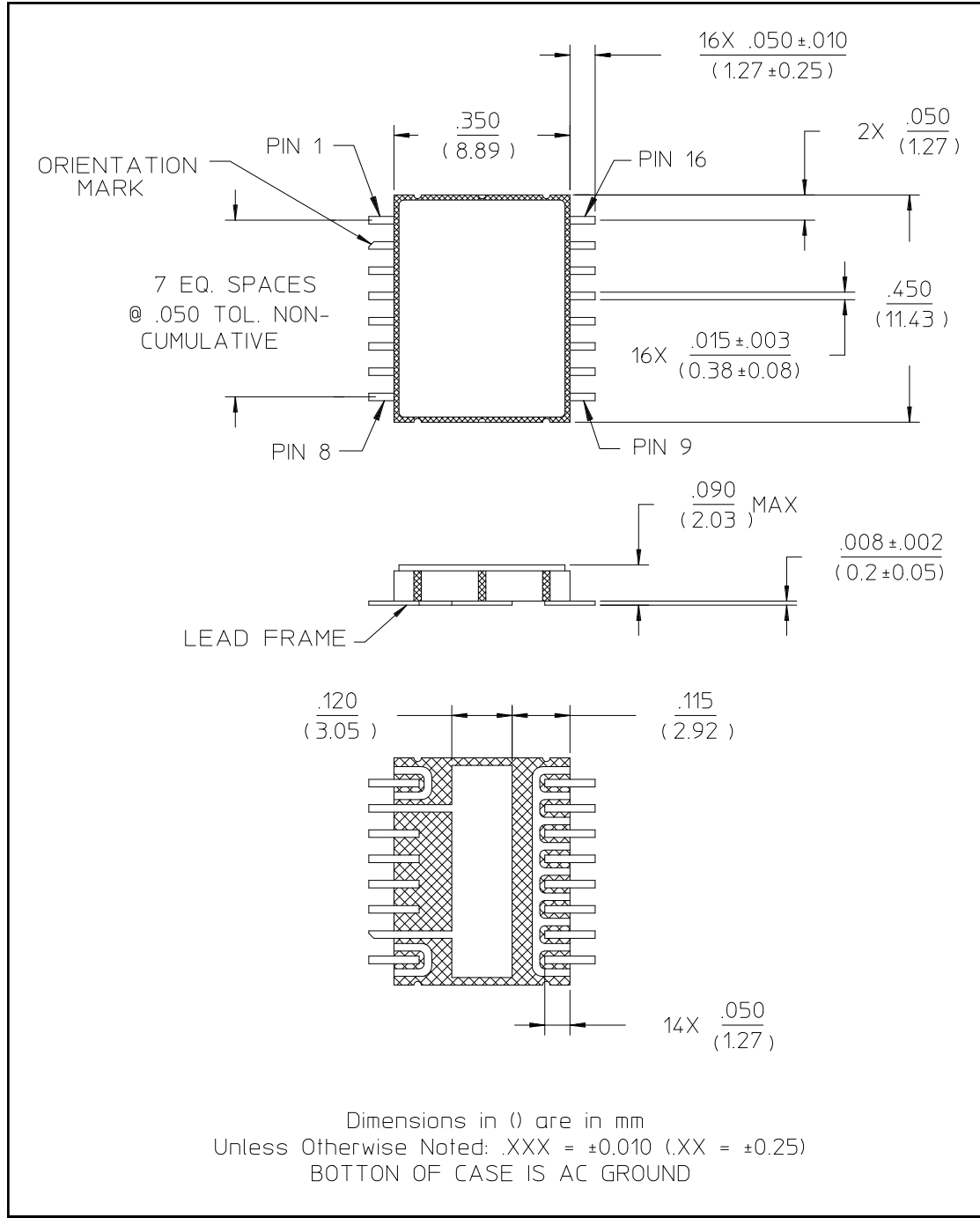

† Reference Application Note M538 for lead-free solder reflow recommendations.