

**DATA SHEET**

# ATN3580 Series: Fixed Attenuator Pads

## Applications

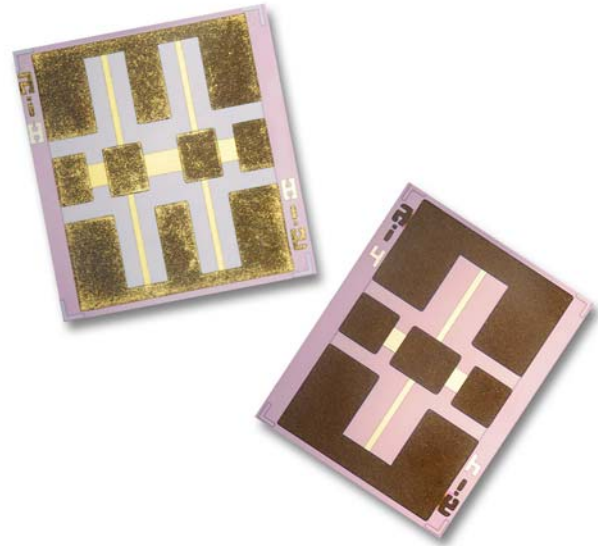
- Attenuators

## Features

- Specified flat response to 40 GHz
- Return loss > 16 dB to 40 GHz
- Available at 1–10, 12, 15, 20, 30 and 40 dB
- Power handling to 1 W CW
- Rugged thin-film silicon chips
- Lead (Pb)-free, RoHS-compliant, and Green™

## Description

The ATN3580 series of attenuator chips incorporates thin-film resistors on high-resistivity silicon to achieve precision attenuation, tight flatness and excellent return loss to 40 GHz. The design uses a balanced TEE resistive structure to assure broad bandwidth performance. The thin-film technology offers improved power-handling capability in comparison to the traditional thick-film printed attenuator. All ATN3580 attenuator chips are specified for their attenuation at DC. A wafer probe sample test is performed to 40 GHz to assure the flatness specification. The absolute maximum ratings are shown in Table 1. Electrical specifications and minimum return loss are provided in Tables 2 and 3, respectively. Typical performance characteristics are shown in Figures 1 and 2. Drawings for suggested die mount and ribbon attachment, product outlines, and a suggested land pattern are shown in Figures 3 through 7.



**Table 1. Absolute Maximum Ratings**

Characteristic	Value
Incident power @ 25 °C	1 W
Operating temperature	–55 °C to +150 °C
Storage temperature	–65 °C to +150 °C
Electrostatic discharge:	
Charged-Device Model (CDM), Class 4	1000 V
Human Body Model (HBM), Class 2	2000 V
Machine Model (MM), Class B	200 V

**Note:** Exposure to maximum rating conditions for extended periods may reduce device reliability. There is no damage to device with only one parameter set at the limit and all other parameters set at or below their nominal value. Exceeding any of the limits listed here may result in permanent damage to the device.



Skyworks Green™ products are compliant with all applicable legislation and are halogen-free. For additional information, refer to *Skyworks Definition of Green™*, document number SQ04-0074.

**CAUTION:** Although this device is designed to be as robust as possible, Electrostatic Discharge (ESD) can damage this device. This device must be protected at all times from ESD. Static charges may easily produce potentials of several kilovolts on the human body or equipment, which can discharge without detection. Industry-standard ESD precautions should be used at all times.

**Table 2. Electrical Specifications at 25 °C**

Nominal Attenuation (dB)	DC Tolerance (dB)	Attenuator Flatness			Outline Drawing	Part Number
		0.1 to 12 GHz (dB)	0.1 to 26.5 GHz (dB)	0.1 to 40 GHz (dB)		
1	±0.15	0.2	0.4	0.6	516-060	ATN3580-01
2	±0.15	0.2	0.4	0.6	516-060	ATN3580-02
3	±0.25	0.2	0.4	0.6	516-060	ATN3580-03
4	±0.25	0.2	0.4	0.6	516-060	ATN3580-04
5	±0.25	0.3	0.5	0.8	516-060	ATN3580-05
6	±0.25	0.3	0.5	0.8	518-060	ATN3580-06
7	±0.25	0.3	0.5	0.8	518-060	ATN3580-07
8	±0.35	0.3	0.5	0.8	518-060	ATN3580-08
9	±0.35	0.3	0.5	0.8	518-060	ATN3580-09
10	±0.35	0.4	0.6	1.0	518-060	ATN3580-10
12	±0.50	0.4	0.6	1.0	518-060	ATN3580-12
15	±0.50	0.4	0.6	1.0	518-060	ATN3580-15
20	±1.10	0.4	0.6	1.0	518-060	ATN3580-20
30	±1.60	0.6	1.0	2.0	518-060	ATN3580-30
40	±1.60	1.0	2.0	4.0	518-060	ATN3580-40

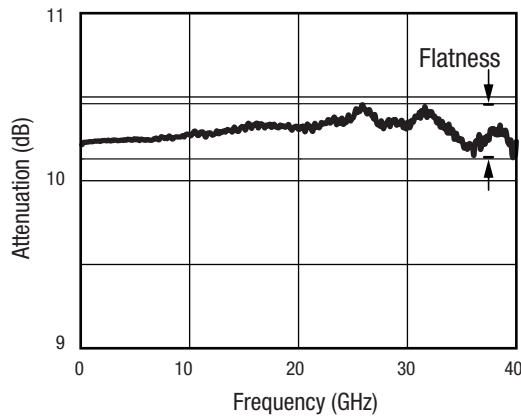
**Note:** Performance is guaranteed only under the conditions listed in this Table.

**Table 3. Minimum Return Loss S<sub>11</sub>**

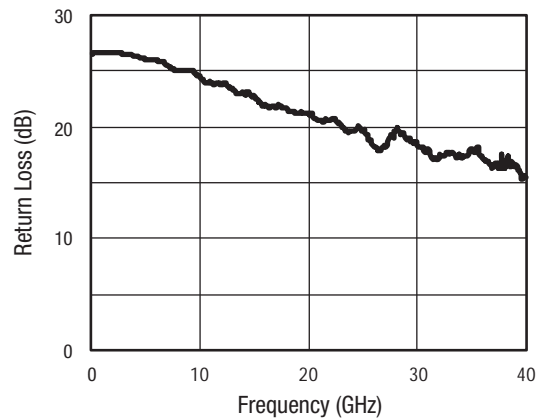
	0.1 to 7 GHz (dB)	0.1 to 12 GHz (dB)	0.1 to 26.5 GHz (dB)	0.1 to 40 GHz (dB)
ATN3580 Series	25	23	18	15

**Note:** Performance is guaranteed only under the conditions listed in this Table.

**Typical Performance Characteristics**

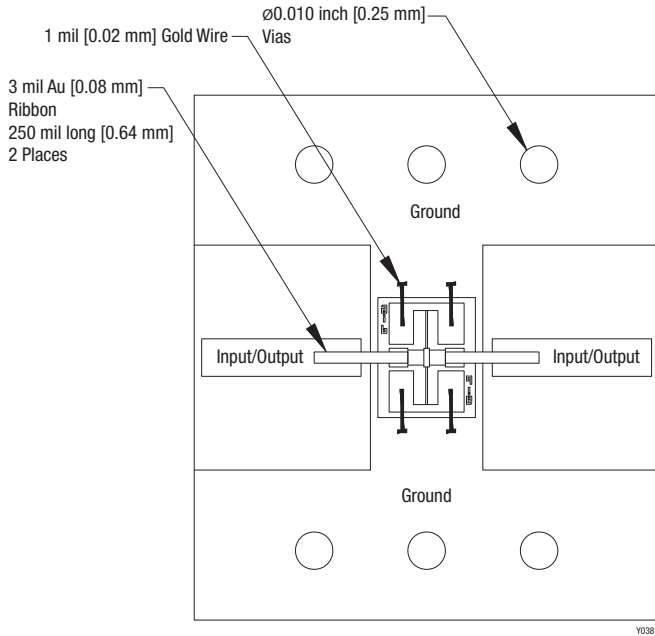


**Figure 1. ATN3580-10  
Typical Attenuation vs Frequency**

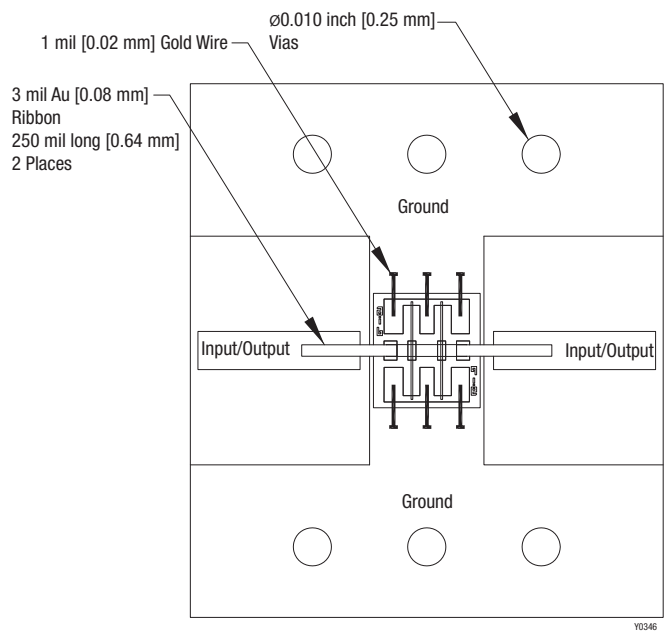


**Figure 2. ATN3580-10  
Typical Input Return Loss vs Frequency**

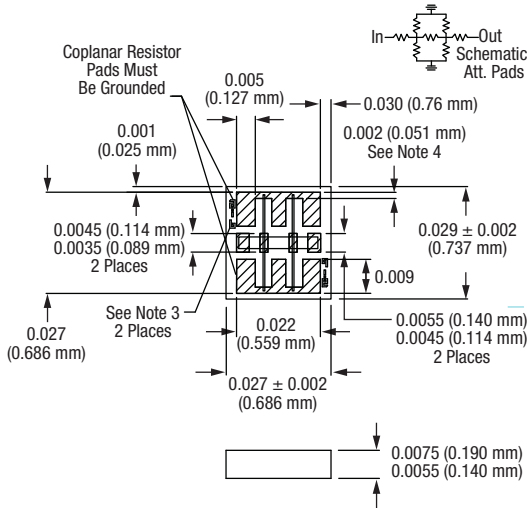
**Suggested Die Mount and Ribbon Attachment Drawings, Outline Drawings, and a Suggested Land Pattern**



**Figure 3. Suggested Die Mount and Ribbon Attachment (1 to 5 dB)**

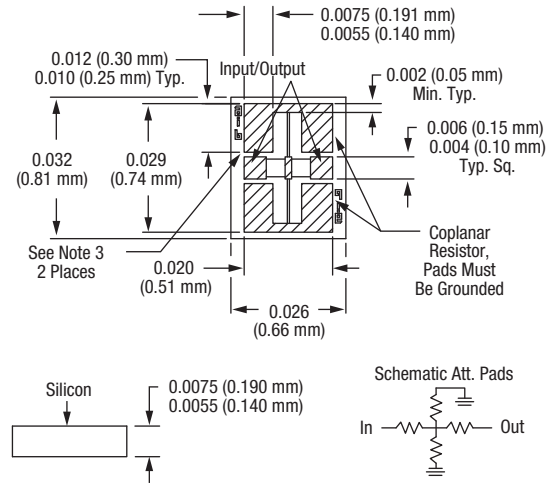


**Figure 4. Suggested Die Mount and Ribbon Attachment (≥ 6 dB)**



1. Cross hatching = gold contact areas.
2. Dimensions not specified in this drawing vary per attenuation value.
3. Indicates attenuation value.
4. This dimension can be as high as 0.012 for high attenuation values.

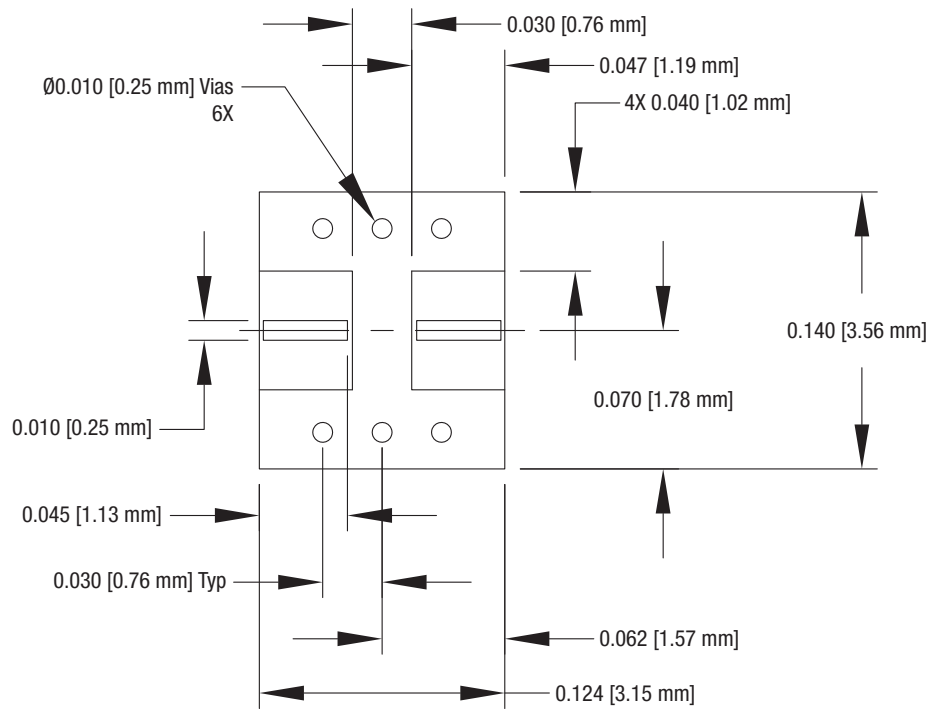
**Figure 5. 518-060 Outline Drawing**



1. Cross hatching = gold contact areas.
2. Dimensions not specified in this drawing vary per attenuation value.
3. Indicates attenuation value.
4. This dimension can be as high as 0.012 for high attenuation values.

**Figure 6. 516-060 Outline Drawing**

**DATA SHEET • ATN3580 SERIES: FIXED ATTENUATOR PADS**



**Notes:**

1. Material: Alumina 99.6%  
 Dielectric Constant: 9.9  
 Effective Dielectric Constant: 6.8  
 Transmission Line Width: 0.010 inch  
 Substrate Thickness: 0.010 inch  
 Coplanar Gap: 0.025 inch
2. Plating: Gold 100 to 150 micro-inches
3. Unless otherwise specified:  
 Dimensions are in inches  
 Tolerances on finish: RMS 63  
 Angles  $\pm 0.5^\circ$  Fractions:  $\pm 1/64$   
 4 place decimals:  $\pm 0.0005$   
 3 place decimals:  $\pm 0.005$   
 2 place decimals:  $\pm 0.02$
4. Commercial published tolerances shall apply to tubing, bar, plate, etc. All threads to be Class 2A or Class 2B. Plated parts must fit gauges and meet specified tolerances after plating.

Y0344

**Figure 7. Suggested Land Pattern**