

**DATA SHEET**

# ATN3590 Series: Fixed Attenuators

## Applications

- Level adjustment in radios, radars, EW/ECM equipment, and test instruments

## Features

- Fixed value, absorptive devices
- Available attenuation values range from 0 to 10 dB (in 1 dB steps), and 12, 15, 20, and 30 dB
- Suitable for use to 40 GHz or higher
- Excellent return loss: 30 dB, typical
- Enhanced power handling: 2 W



Skyworks Green™ products are compliant with all applicable legislation and are halogen-free. For additional information, refer to *Skyworks Definition of Green™*, document number SQ04-0074.

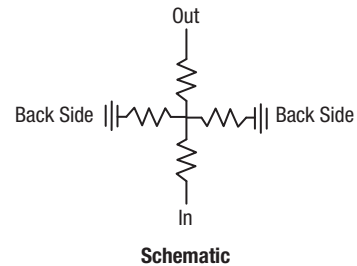
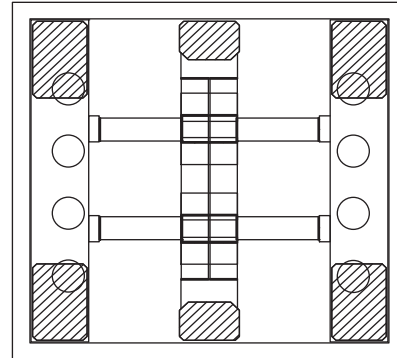

**Figure 1. Typical Attenuator Die and Circuit**

## Description

The ATN3590 family of fixed resistive attenuators are integrated circuits comprising thin film resistors and through-die vias that provide excellent attenuation flatness from low frequency to 40 GHz or higher. These attenuators are available from 0 to 30 dB (see Table 2).

The ATN3590 attenuator family is optimized for surface mounting on co-planar waveguide or microstrip printed circuit boards. Bond wires or ribbons are used to connect the input and output ports of the attenuators to the external circuit transmission lines. Connection to ground is accomplished by through-die vias to the die backside metallization.

The dice are attached using eutectic solder or conductive epoxy and can operate over a temperature range of -65 °C to 150 °C.

The absolute maximum ratings for the ATN3590 attenuators are provided in Table 1, and the electrical specifications are shown in Table 2. Typical performance characteristics are illustrated in Figures 2 through 8.

**Table 1. ATN3590 Series Absolute Maximum Ratings<sup>1</sup>**

Parameter	Symbol	Minimum	Typical	Maximum	Units
Input power	P <sub>IN</sub>			2	W
Power dissipation @ 25 °C	P <sub>DIS</sub>			2	W
Operating temperature	T <sub>OP</sub>	-55		+150	°C
Storage temperature	T <sub>STG</sub>	-55		+150	°C

<sup>1</sup> Exposure to maximum rating conditions for extended periods may reduce device reliability. There is no damage to device with only one parameter set at the limit and all other parameters set at or below their nominal value. Exceeding any of the limits listed here may result in permanent damage to the device.

**ESD HANDLING:** Although this device is designed to be as robust as possible, electrostatic discharge (ESD) can damage this device. This device must be protected at all times from ESD when handling or transporting. Static charges may easily produce potentials of several kilovolts on the human body or equipment, which can discharge without detection. Industry-standard ESD handling precautions should be used at all times.

**Table 2. ATN3590Series Electrical Specifications<sup>1</sup>**

(T<sub>OP</sub> = +25 °C, Characteristic Impedance [Z<sub>0</sub>] = 50 Ω, Unless Otherwise Noted)

Part Number	Attenuation (dB)	Attenuation Tolerance @ DC (dB)	Attenuation Flatness (Note 2) DC–12 GHz (dB)	Attenuation Flatness (Note 2) 12–26 GHz (dB)	Attenuation Flatness (Note 2) 26–33 GHz (dB)	Attenuation Flatness (Note 2) 33–40 GHz (dB)	Min. Return Loss DC–12 GHz (dB)	Min. Return Loss 12–26 GHz (dB)	Min. Return Loss 26–33 GHz (dB)	Min. Return Loss 33–40 GHz (dB)
ATN3590-00	0	0.25	±0.15	±0.15	±0.20	±0.20	28	24	20	16
ATN3590-01	1	±0.20	±0.15	±0.15	±0.20	±0.20	28	24	20	16
ATN3590-02	2	±0.20	±0.15	±0.15	±0.20	±0.20	28	24	20	16
ATN3590-03	3	±0.20	±0.15	±0.15	±0.20	±0.20	28	24	20	16
ATN3590-04	4	±0.20	±0.15	±0.15	±0.20	±0.20	28	24	20	16
ATN3590-05	5	±0.20	±0.15	±0.15	±0.20	±0.20	28	24	20	16
ATN3590-06	6	±0.40	±0.15	±0.15	±0.20	±0.20	28	24	20	16
ATN3590-07	7	±0.40	±0.15	±0.15	±0.20	±0.20	28	24	20	16
ATN3590-08	8	±0.40	±0.15	±0.15	±0.20	±0.20	28	24	20	16
ATN3590-09	9	±0.40	±0.20	±0.20	±0.25	±0.30	28	24	20	16
ATN3590-10	10	±0.40	±0.20	±0.20	±0.25	±0.50	28	24	20	16
ATN3590-12	12	±0.40	±0.20	±0.20	±0.30	±0.50	28	24	20	16
ATN3590-15	15	±0.40	±0.20	±0.20	±0.50	±0.75	28	24	20	16
ATN3590-20	20	±1.0	±0.20	±0.20	±0.75	±1.00	28	24	20	16
ATN3590-30	30	±1.0	±0.20	±0.25	±0.75	±2.50	28	24	20	16

<sup>1</sup> Performance is guaranteed only under the conditions listed in this Table.

<sup>2</sup> Flatness is defined as the maximum deviation from the mean value of attenuation over the specified frequency range.

## Typical Performance Characteristics

(TOP = +25 °C, Characteristic Impedance [Z<sub>0</sub>] = 50 Ω, Unless Otherwise Noted. Data Gathered Using Ground-to-Signal-to-Ground Probes on Die)

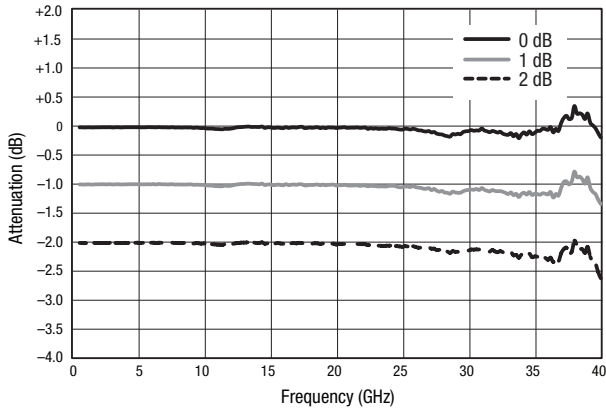

**Figure 2. Attenuation vs Frequency (0 dB, 1 dB, and 2 dB Attenuators)**

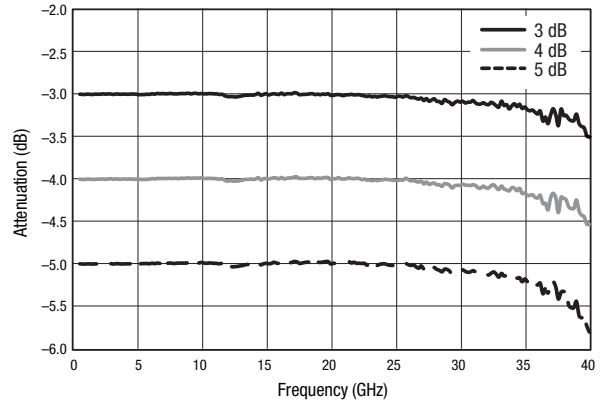

**Figure 3. Attenuation vs Frequency (3 dB, 4 dB, and 5 dB Attenuators)**

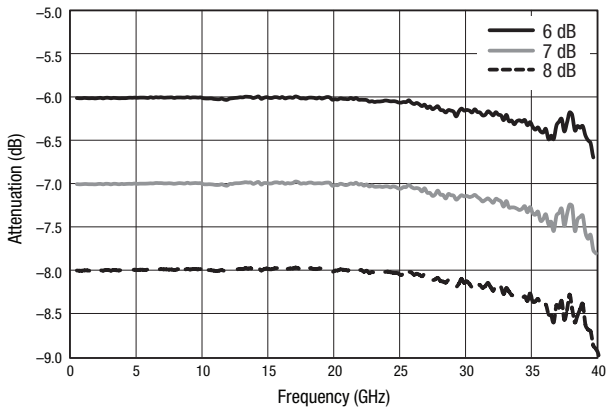

**Figure 4. Attenuation vs Frequency (6 dB, 7 dB, and 8 dB Attenuators)**

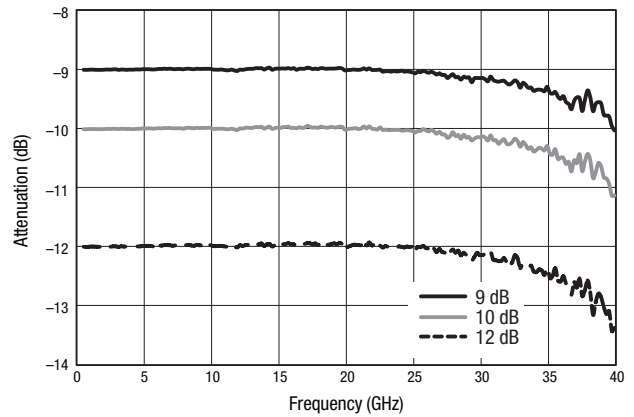

**Figure 5. Attenuation vs Frequency (9 dB, 10 dB, and 12 dB Attenuators)**

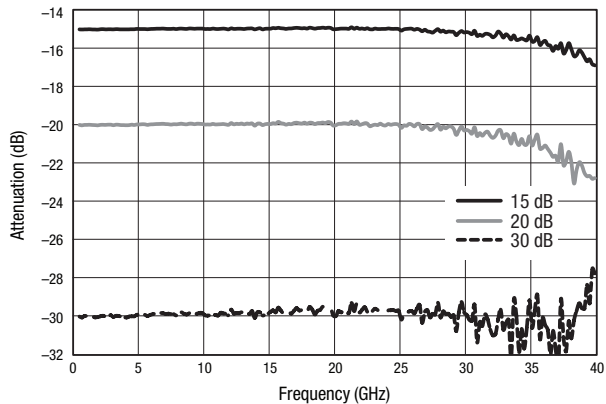

**Figure 6. Attenuation vs Frequency (15 dB, 20 dB, and 30 dB Attenuators)**

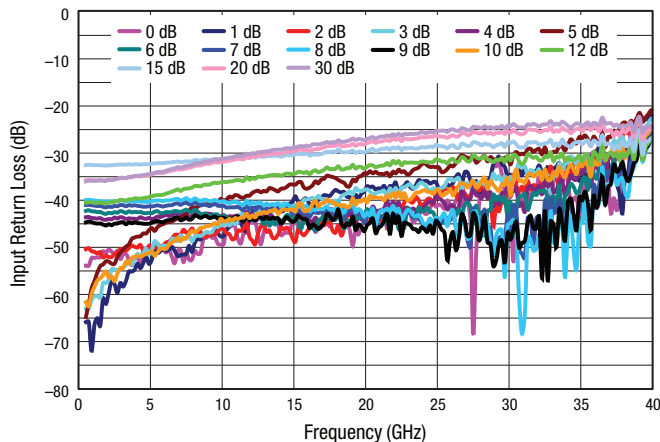

Figure 7. Input Return Loss vs Frequency

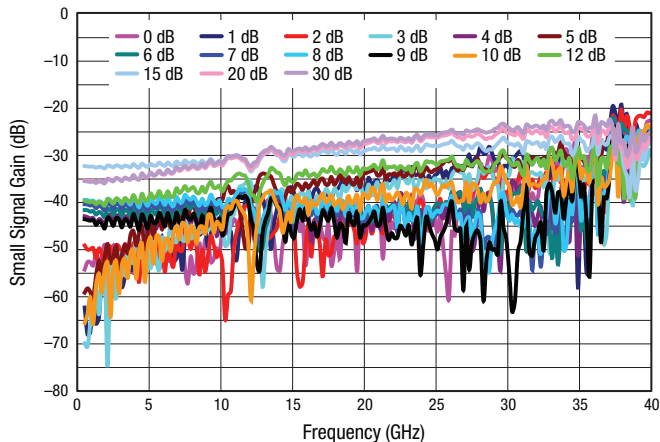

Figure 8. Small Signal Gain vs Frequency

### Technical Description

The ATN3590 family of fixed attenuators comprises devices with nominal attenuation values of 0 to 10 dB (in 1 dB steps), and 12, 15, 20, and 30 dB. These attenuators contain through-wafer vias that connect the topside ground to the backside metallization of each die.

The devices with nominal attenuation values of 1 dB or greater are fabricated using thin film resistors deposited on GaAs substrates. The circuit topology is a simple tee structure that consists of two series resistors and a shunt resistance, which in this case is realized as a pair of shunt resistors connected to the node between the two series resistors (refer to Figures 9 and 10). The resistances of each of these resistors are selected to simultaneously produce the nominal attenuation with very good input and output return losses.

The attenuators with nominal attenuation values  $\geq 6$  dB contain a pair of cascaded tee sections (see Figure 11). The 0 dB attenuator, ATN3590-00, is a 50  $\Omega$  microstrip transmission line with identical foot print and bond pads to those of the other products in this family.

### Die Attachment and Signal Path Connection

Any of the ATN3590 family of attenuators should be mounted on the ground plane of a transmission medium. The die should be attached with conductive epoxy or a eutectic solder such as gold/tin (AuSn).

For good high frequency performance, it is essential that there is no ground plane directly beneath the series signal path of the ATN3590. The backside metallization on the die is split into two regions along the sides of the die to accommodate this requirement.

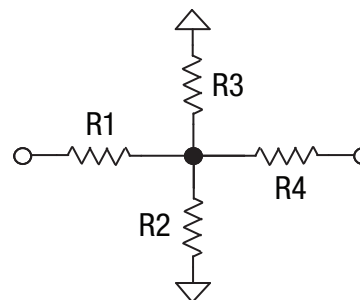

Figure 9. Circuit Topology (1 to 5 dB Attenuators)

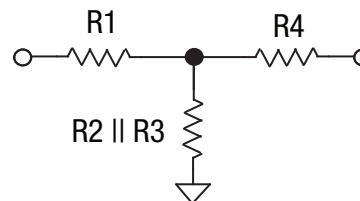

Figure 10. Simplified Circuit Topology (1 to 5 dB Attenuators)

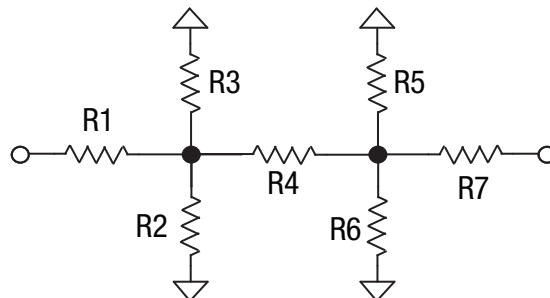

Figure 11. Circuit Topology for Attenuators with Nominal Attenuation  $\geq 6$  dB

The metallization on the circuit medium to which the attenuator is to be mounted must also include the split in the ground connections. It is recommended the gap between the ground pads on the circuit medium be 250  $\mu\text{m}$  wide by 900  $\mu\text{m}$  long.

It is recommended that the signal paths be connected to the input/output bond pads on the attenuator with 0.25 mil thick x 3 mil wide (6.25 x 75 microns) Au ribbons, as shown in Figure 12. Au wires can also be used.

### Package Dimensions

The PCB layout footprint for the ATN3590 attenuators is shown in Figure 13. Package dimensions are provided in Figure 14.

### Packaging

The standard mode of packaging for shipment of the ATN3590 Attenuator Series is 100 pieces per GelPak™.

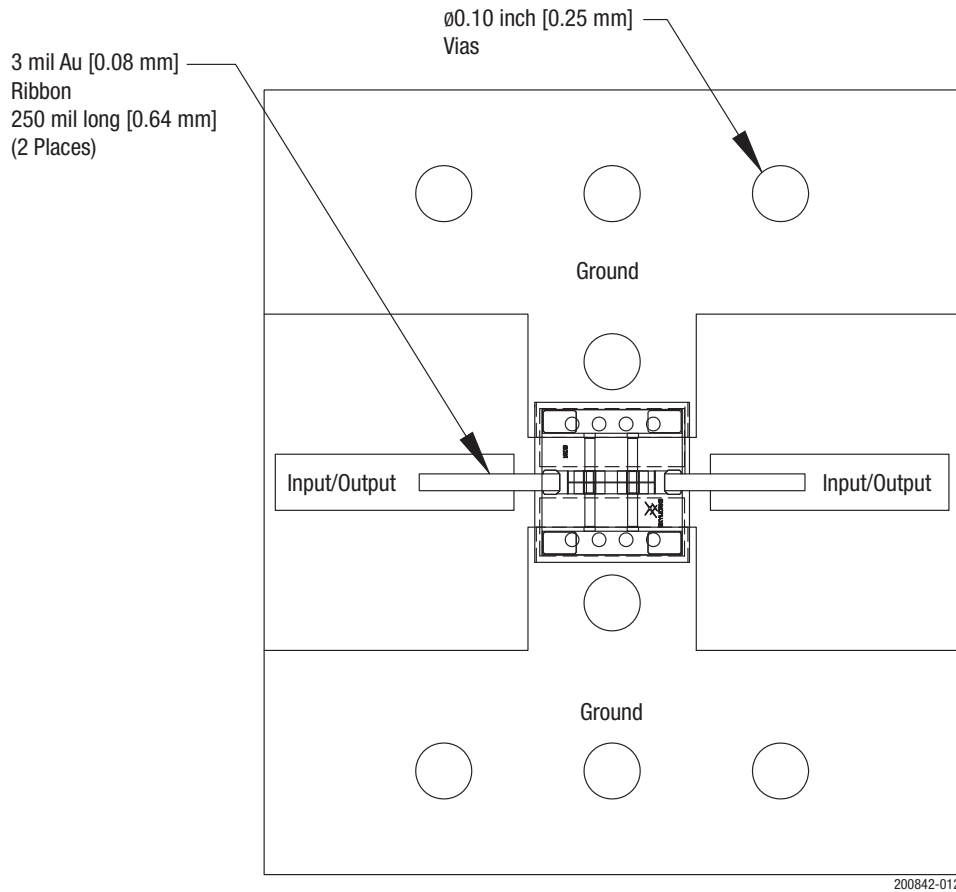

**Figure 12. Suggested Die Mount and Ribbon Attachment**

**DATA SHEET • ATN3590 SERIES FIXED ATTENUATORS**

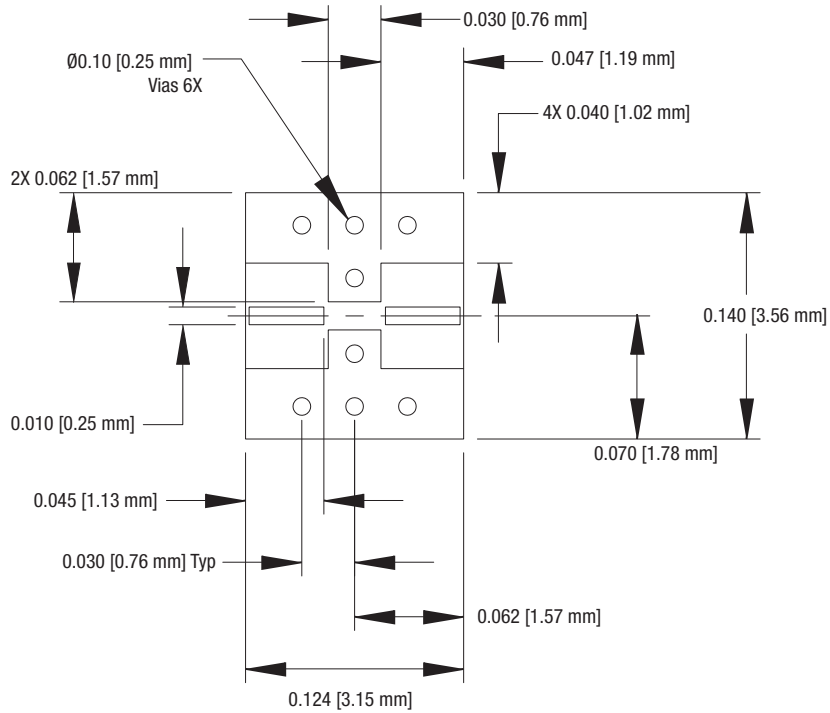

**Notes:**

1. Material: Alumina 99.6%  
Dielectric constant 9.9  
Effective dielectric constant 6.8  
Transmission line width: 0.010"  
Substrate thickness: 0.010"  
Coplanar gap: 0.025"
2. Plating: Gold 100 to 150 micro-inches
3. Unless otherwise specified:  
Dimensions are in inches  
Tolerances on finish: RMS 63  
Angles  $\pm 0.5^\circ$  Fractions:  $\pm 1/64$   
4 place decimals:  $\pm 0.0005$   
3 place decimals:  $\pm 0.005$   
2 place decimals:  $\pm 0.02$
4. Commercial published tolerances shall apply to tubing, bar, plate, etc. All threads to be Class 2A or Class 2B. Plated parts must fit gauges and meet specified tolerances after plating.

200842-013

**Figure 13. Suggested Land Pattern**