

ATV66SM8T-HF Series

Working Peak Reverse Voltage: 16 to 43 V

Peak Pulse Power: 6600 W

RoHS Device

Halogen Free



Features

- Glass passivated junction technology.
- $T_J=175^{\circ}\text{C}$ capability suitable for high reliability and automotive requirement.
- 6600W peak pulse power capability with a 10/1000 μs waveform, repetition rate (duty cycles): 0.01%.
- Low leakage current.
- Low forward voltage drop for uni-directional polarity.
- Both available in uni-directional and bi-directional polarity.
- Excellent clamping capability.
- Very fast response time.
- AEC-Q101 Qualified.

Mechanical data

- Case: DO-218AB, molded plastic.
- Molding compound: UL 94V-0 flammability.
- Polarity: Heatsink is anode.
- Terminal: Solderable per MIL-STD-750, method 2026.
- Mounting position: Any.

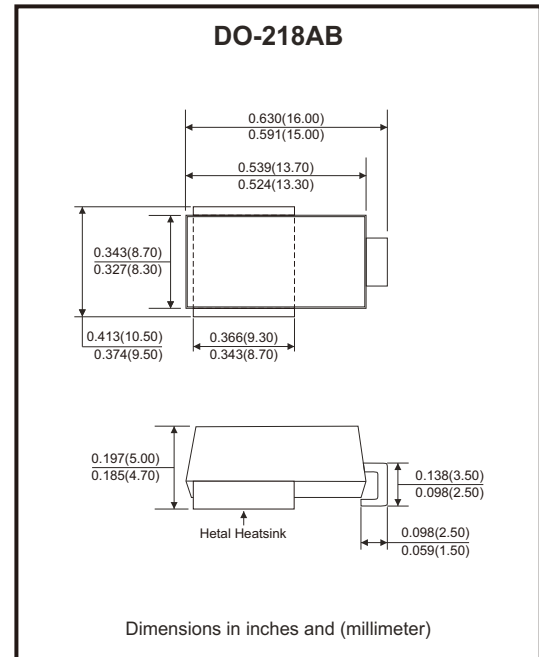

Circuit Diagram

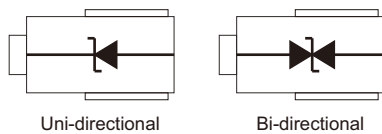

Maximum Ratings ($T_A=25^{\circ}\text{C}$ unless otherwise noted)

Characteristics	Symbol	Value	Units
Peak power dissipation with a 10/1000 μs waveform (Note 1)	P_{PP}	6600	W
Peak power dissipation with a 10/1000 μs waveform for unidirectional polarity	P_{PP}	5200	W
Peak pulse current with a 10/1000 μs waveform (Note 1)	I_{PP}	See next table	A
Power dissipation on infinite heatsink at $T_L = 25^{\circ}\text{C}$	P_D	8	W
Peak forward surge current, 8.3ms single half sine-wave	I_{FSM}	700	A
Operating junction and storage temperature range	T_J, T_{STG}	-55 to +175	$^{\circ}\text{C}$

Notes: 1. Non-repetitive current pulse, per Fig.2 and derated above $T_a=25^{\circ}\text{C}$ per Fig.1 .

Electrical Characteristics (TA=25°C unless otherwise noted)

Part No	Breakdown voltage V _{BR} @ I _T			Maximum reverse leakage @V _{RWM} I _R (μA)	Maximum I _R @V _{RWM} T _J =175°C (μA)	Working peak reverse voltage V _{RWM} (V)	Maximum reverse surge current I _{PP} (A) (Note1)	Maximum clamping voltage @I _{PP} V _C (V)	Marking code	
	Min(V)	Max(V)	I _T (mA)						Uni	Bi
ATV66SM8T16(C)A-HF	17.8	19.7	5	10	150	16	254	26.0	SM8T16A	SM8T16CA
ATV66SM8T17(C)A-HF	18.9	20.9	5	10	150	17	239	27.6	SM8T17A	SM8T17CA
ATV66SM8T18(C)A-HF	20.0	22.1	5	10	150	18	226	29.2	SM8T18A	SM8T18CA
ATV66SM8T20(C)A-HF	22.2	24.5	5	10	150	20	204	32.4	SM8T20A	SM8T20CA
ATV66SM8T22(C)A-HF	24.4	26.9	5	10	150	22	186	35.5	SM8T22A	SM8T22CA
ATV66SM8T24(C)A-HF	26.7	29.5	5	10	150	24	170	38.9	SM8T24A	SM8T24CA
ATV66SM8T26(C)A-HF	28.9	31.9	5	10	150	26	157	42.1	SM8T26A	SM8T26CA
ATV66SM8T28(C)A-HF	31.1	34.4	5	10	150	28	145	45.4	SM8T28A	SM8T28CA
ATV66SM8T30(C)A-HF	33.3	36.8	5	10	150	30	136	48.4	SM8T30A	SM8T30CA
ATV66SM8T33(C)A-HF	36.7	40.6	5	10	150	33	124	53.3	SM8T33A	SM8T33CA
ATV66SM8T36(C)A-HF	40.0	44.2	5	10	150	36	114	58.1	SM8T36A	SM8T36CA
ATV66SM8T40(C)A-HF	44.4	49.1	5	10	150	40	102	64.5	SM8T40A	SM8T40CA
ATV66SM8T43(C)A-HF	47.8	52.8	5	10	150	43	95	69.4	SM8T43A	SM8T43CA

Notes: 1. Surge current waveform is defined at 10/1000μs waveform.

2. For uni-directional part, the max. VF=1.8V at IF=100A measured on 8.3ms single half sine-wave or equivalent square wave, duty cycle=4 pulses per minute maximum.

3. For Bi-directional devices, use suffix CA.

Rating and Characteristic Curves (ATV66SM8T-HF Series-HF)

Fig.1 - Power Derating Curve

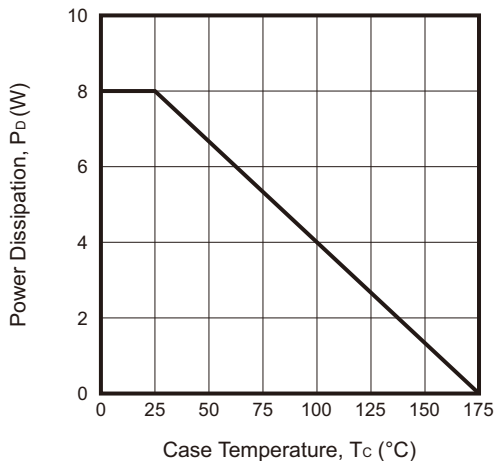

Fig.2 - Pulse Waveform

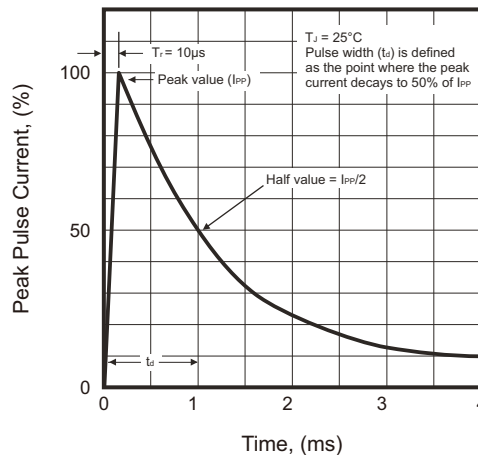

Fig.3 - Typical Thermal Impedance

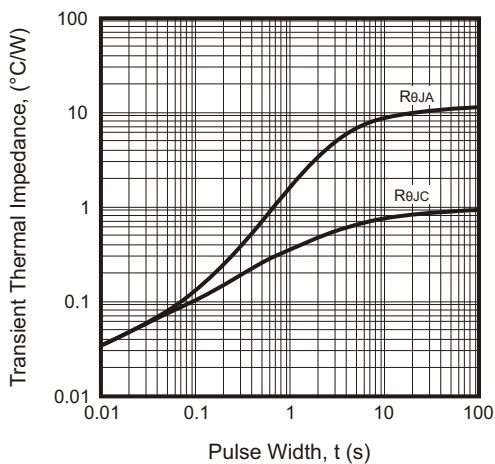
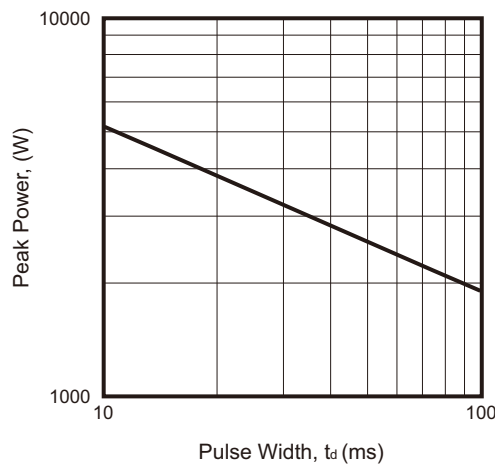
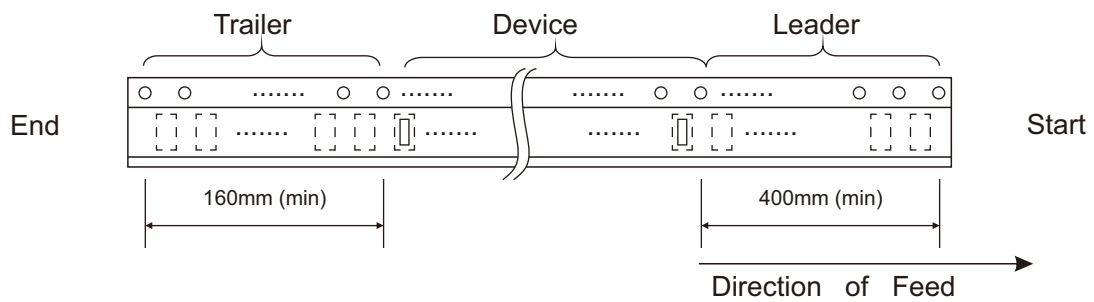
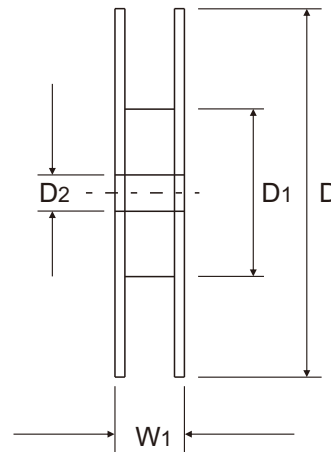
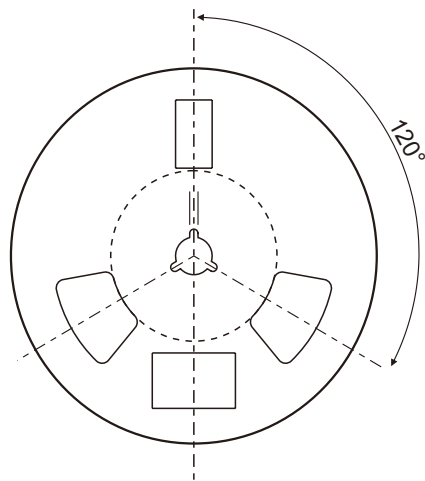
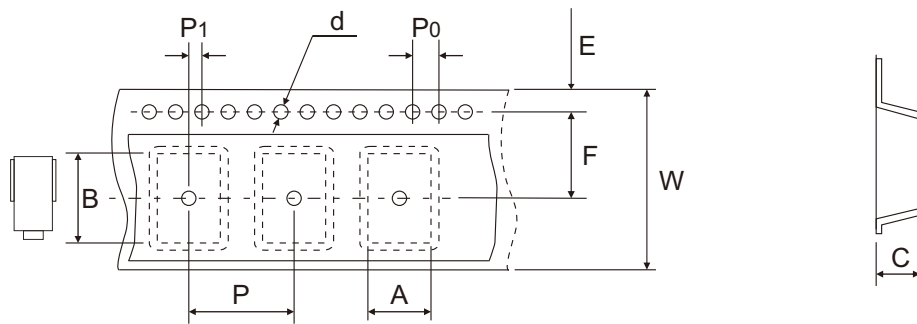

Fig.4 - Peak Pulse Power Rating Curve



Reel Taping Specification



DO-218AB	SYMBOL	A	B	C	d	D	D1	D2
	(mm)	10.77 ± 0.20	16.33 ± 0.20	6.02 ± 0.20	1.50 ± 0.10	330	60 Min	$13.00 + 0.50$ $- 0.20$
	(inch)	0.424 ± 0.008	0.643 ± 0.008	0.237 ± 0.008	0.059 ± 0.004	12.992	2.362 Min	$0.512 + 0.020$ $- 0.008$

DO-218AB	SYMBOL	E	F	P	P0	P1	W	W1
	(mm)	1.75 ± 0.10	11.50 ± 0.10	16.00 ± 0.10	4.00 ± 0.10	2.00 ± 0.10	24.00 ± 0.30	30.40 Max
	(inch)	0.069 ± 0.004	0.453 ± 0.004	0.630 ± 0.004	0.157 ± 0.004	0.079 ± 0.004	0.945 ± 0.012	1.197 Max

Company reserves the right to improve product design, functions and reliability without notice.

REV:A