

Features

- Floating channel designed for bootstrap operation
- Fully operational to +600 V
- Tolerant to negative transient voltage - dV/dt immune
- Gate drive supply range from 10 V to 20 V
- Undervoltage lockout
- CMOS Schmitt-triggered inputs with pull-down (AUIRS2117) or pull-up (AUIRS2118)
- Output in phase with input (AUIRS2117) or out of Phase with input (AUIRS2118)
- Leadfree, RoHS compliant
- Automotive qualified*

Typical Applications

- Direct/Piezo injection
- BLDC Motor Drive
- MOSFET and IGBT drivers

Product Summary

Topology	Single High Side
V _{OFFSET}	≤ 600 V
V _{OUT}	10 V – 20 V
I _{o+} & I _{o-} (typical)	290 mA & 600 mA
t _{ON} & t _{OFF} (typical)	140 ns & 140 ns

Package Options

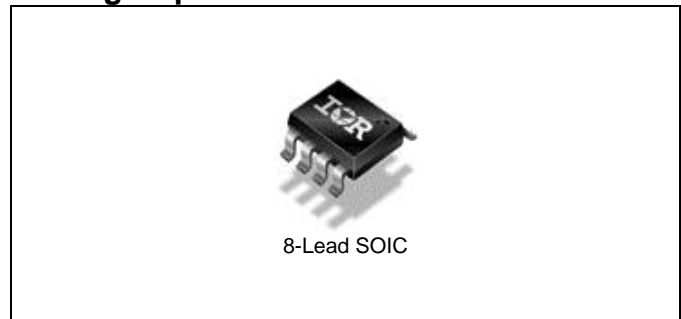

Typical Connection Diagram

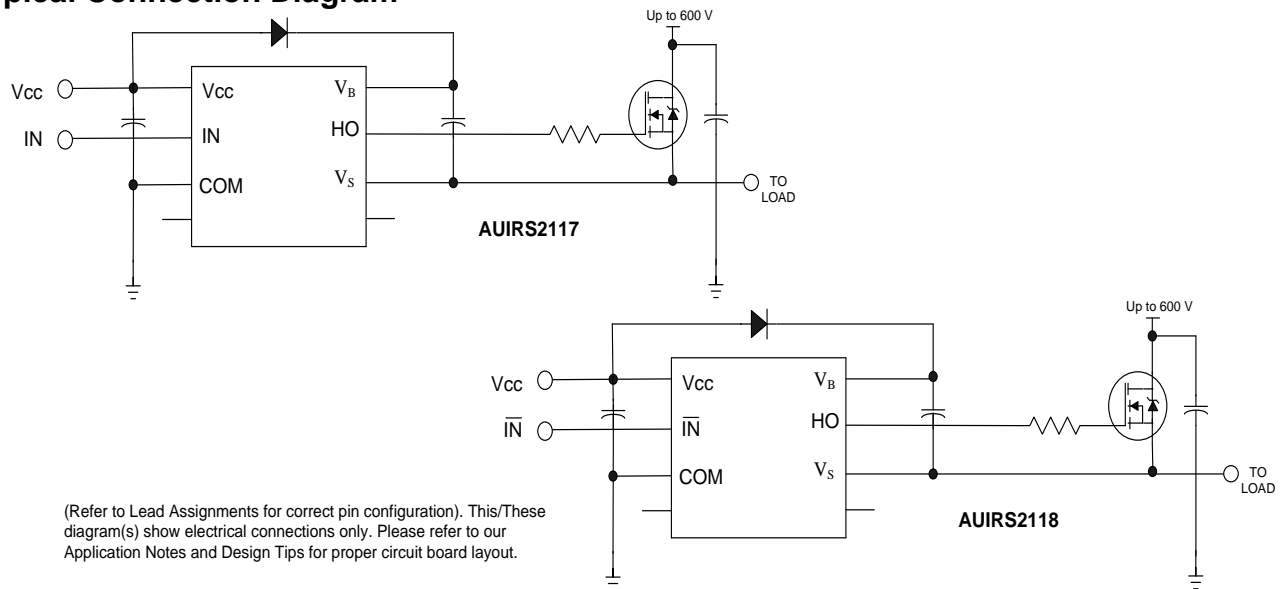

Table of Contents	Page
Description	3
Qualification Information	4
Absolute Maximum Ratings	5
Recommended Operating Conditions	5
Static Electrical Characteristics	6
Dynamic Electrical Characteristics	6
Functional Block Diagram	7
Input/Output Pin Equivalent Circuit Diagram	8
Lead Definitions	9
Lead Assignments	9
Application Information and Additional Details	10-13
Parameter Temperature Trends	13-16
Package Details	17
Tape and Reel Details	18
Part Marking Information	19
Ordering Information	20

Description

The AUIRS2117S/AUIRS2118S are high voltage, high speed power MOSFET and IGBT drivers. Proprietary HVIC and latch immune CMOS technologies enable ruggedized monolithic construction. The logic input is compatible with standard CMOS outputs. The output drivers feature a high pulse current buffer stage. The floating channel can be used to drive an N-channel power MOSFET or IGBT in the high- side or low-side configuration which operates up to 600 V.

Qualification Information[†]

Qualification Level		Automotive (per AEC-Q100)	
		Comments: This family of ICs has passed an Automotive qualification. IR's Industrial and Consumer qualification level is granted by extension of the higher Automotive level.	
Moisture Sensitivity Level		SOIC8N	MSL3 ^{††} 260°C (per IPC/JEDEC J-STD-020)
ESD	Machine Model	Class M2 (Pass +/-200V) (per AEC-Q100-003)	
	Human Body Model	Class H1B (Pass +/-1000V) (per AEC-Q100-002)	
	Charged Device Model	Class C4 (Pass +/-1000V) (per AEC-Q100-011)	
IC Latch-Up Test		Class II, Level A (per AEC-Q100-004)	
RoHS Compliant		Yes	

† Qualification standards can be found at International Rectifier's web site <http://www.irf.com/>

†† Higher MSL ratings may be available for the specific package types listed here. Please contact your International Rectifier sales representative for further information.

Absolute Maximum Ratings

Absolute Maximum Ratings indicate sustained limits beyond which damage to the device may occur. All voltage parameters are absolute voltages referenced to COM lead. Stresses beyond those listed under "Absolute Maximum Ratings" may cause permanent damage to the device. These are stress ratings only; and functional operation of the device at these or any other condition beyond those indicated in the "Recommended Operating Conditions" is not implied. Exposure to absolute-maximum-rated conditions for extended periods may affect device reliability. The thermal resistance and power dissipation ratings are measured under board mounted and still air conditions. Ambient temperature (T_A) is 25°C, unless otherwise specified.

Symbol	Definition	Min.	Max.	Units
V_B	High-side floating absolute voltage	-0.3	625	V
V_S	High-side floating supply offset voltage	$V_B - 25$	$V_B + 0.3$	
V_{HO}	High-side floating output voltage	$V_S - 0.3$	$V_B + 0.3$	
V_{CC}	Logic supply voltage	-0.3	25	
V_{IN}	Logic input voltage	-0.3	$V_{CC} + 0.3$	
dV_S/dt	Allowable offset supply voltage transient (Fig. 2)	—	50	V/ns
P_D	Package power dissipation @ $T_A \leq 25^\circ\text{C}$	—	0.625	W
R_{thJA}	Thermal resistance, junction to ambient	—	200	°C/W
T_J	Junction temperature	—	150	°C
T_S	Storage temperature	-55	150	
T_L	Lead temperature (soldering, 10 seconds)	—	300	

Recommended Operating Conditions

The input/output logic timing diagram is shown in Fig. 1. For proper operation the device should be used within the recommended conditions. The V_S offset rating is tested with all supplies biased at 15 V differential.

Symbol	Definition	Min	Max	Units
V_B	High-side floating supply absolute voltage	$V_S + 10$	$V_S + 20$	V
V_S	High-side floating supply offset voltage	†	600	
V_{HO}	High-side floating output voltage	V_S	V_B	
V_{CC}	Logic supply voltage	10	20	
V_{IN}	Logic input voltage	0	V_{CC}	
T_A	Ambient temperature	-40	125	°C

† Logic operational for V_S of -5 V to +600 V. Logic state held for V_S of -5 V to $-V_{BS}$.
(Please refer to the Design Tip DT97-3 for more details).

Static Electrical Characteristics

Unless otherwise noted, these specifications apply for an operating junction temperature range of $-40^{\circ}\text{C} \leq T_j \leq 125^{\circ}\text{C}$ with bias conditions of $V_{\text{BIAS}} (V_{\text{CC}}, V_{\text{BS}}) = 15 \text{ V}$. The V_{IL} , V_{IH} and I_{IN} parameters are referenced to COM. The V_{O} and I_{O} parameters are referenced to COM and are applicable to the respective output leads: HO.

Symbol	Definition	Min	Typ	Max	Units	Test Conditions		
V_{IH}	Logic "1" input voltage	AUIRS2117	9.5	—	—	V		
		AUIRS2118						
V_{IL}	Logic "0" input voltage	AUIRS2117	—	—	6.0		$I_{\text{O}} = 2 \text{ mA}$	
		AUIRS2118						
V_{OH}	High level output voltage, $V_{\text{BIAS}} - V_{\text{O}}$	—	0.05	0.2				
V_{OL}	Low level output voltage, $V_{\text{O}} \dagger$	—	0.02	0.2				
I_{LK}	Offset supply leakage current	—	—	50	μA			$V_{\text{B}} = V_{\text{S}} = 600 \text{ V}$
I_{QBS}	Quiescent V_{BS} supply current	—	50	240				$V_{\text{IN}} = 0 \text{ V}$ or V_{CC}
I_{QCC}	Quiescent V_{CC} supply current	—	70	340		$V_{\text{IN}} = V_{\text{CC}}$		
$I_{\text{IN+}}$	Logic "1" input bias current	AUIRS2117	—	20		40		$V_{\text{IN}} = 0 \text{ V}$
		AUIRS2118			$V_{\text{IN}} = V_{\text{CC}}$			
$I_{\text{IN-}}$	Logic "0" input bias current	AUIRS2117	—	—	5.0	$V_{\text{IN}} = 0 \text{ V}$		
		AUIRS2118				$V_{\text{IN}} = V_{\text{CC}}$		
$V_{\text{BSUV+}}$	V_{BS} supply undervoltage positive going threshold	7.6	8.6	9.6	V			
$V_{\text{BSUV-}}$	V_{BS} supply undervoltage negative going threshold	7.2	8.2	9.2				
$V_{\text{CCUV+}}$	V_{CC} supply undervoltage positive going threshold	7.6	8.6	9.6				
$V_{\text{CCUV-}}$	V_{CC} supply undervoltage negative going threshold	7.2	8.2	9.2				
$I_{\text{O+}}$	Output high short circuit pulsed current	200	290	—	mA	$V_{\text{O}} = 0 \text{ V}$, $V_{\text{IN}} = \text{Logic "1"}$ $\text{PW} \leq 10 \mu\text{s}$		
$I_{\text{O-}}$	Output low short circuit pulsed current	420	600	—		$V_{\text{O}} = 15 \text{ V}$, $V_{\text{IN}} = \text{Logic "0"}$ $\text{PW} \leq 10 \mu\text{s}$		

Dynamic Electrical Characteristics

Unless otherwise noted, these specifications apply for an operating junction temperature range of $-40^{\circ}\text{C} \leq T_j \leq 125^{\circ}\text{C}$ with bias conditions of $V_{\text{BIAS}} (V_{\text{CC}}, V_{\text{BS}}) = 15 \text{ V}$, $C_{\text{L}} = 1000 \text{ pF}$. The dynamic electrical characteristics are measured using the test circuit shown in Fig. 3.

Symbol	Definition	Min	Typ	Max	Units	Test Conditions
t_{on}	Turn-on propagation delay	—	140	225	ns	$V_{\text{S}} = 0 \text{ V}$
t_{off}	Turn-off propagation delay	—	140	225		$V_{\text{S}} = 600 \text{ V}$
t_{r}	Turn-on rise time	—	75	130		
t_{f}	Turn-off fall time	—	25	65		

Note: Please refer to figures in Parameter Temperature Trends section

Functional Block Diagram: (AUIRS2117)

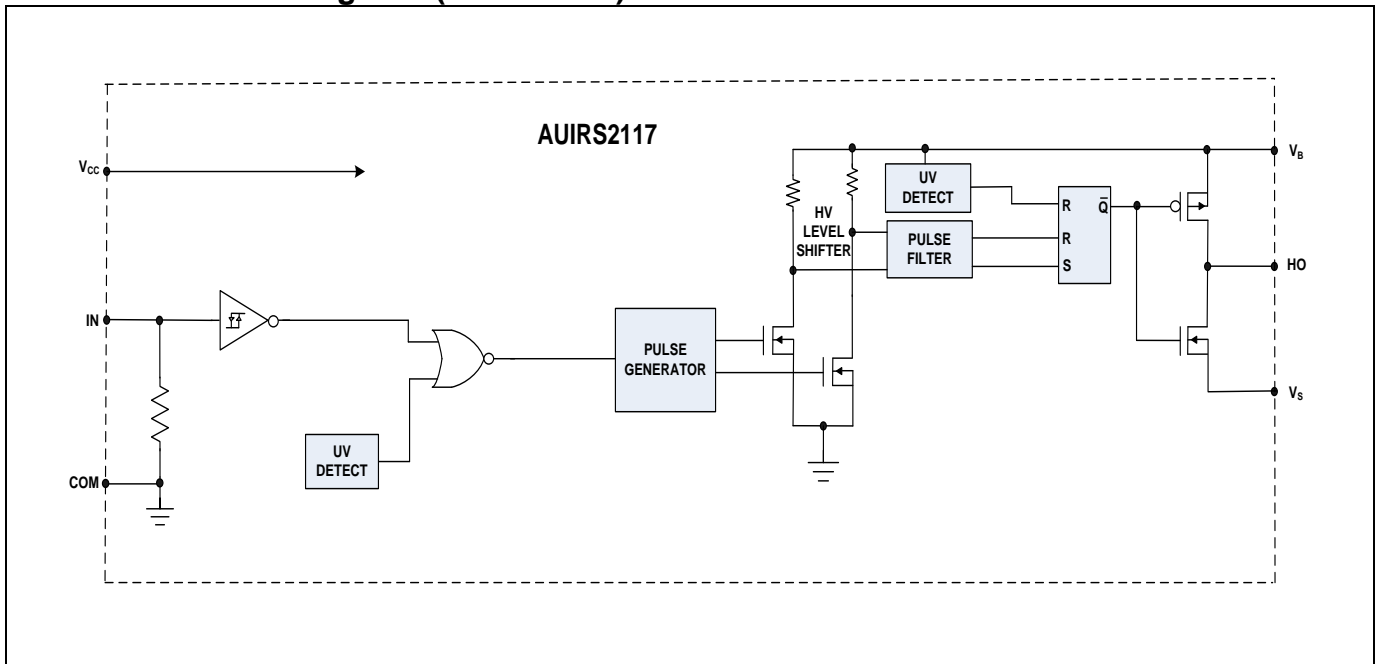

Functional Block Diagram: (AUIRS2118)

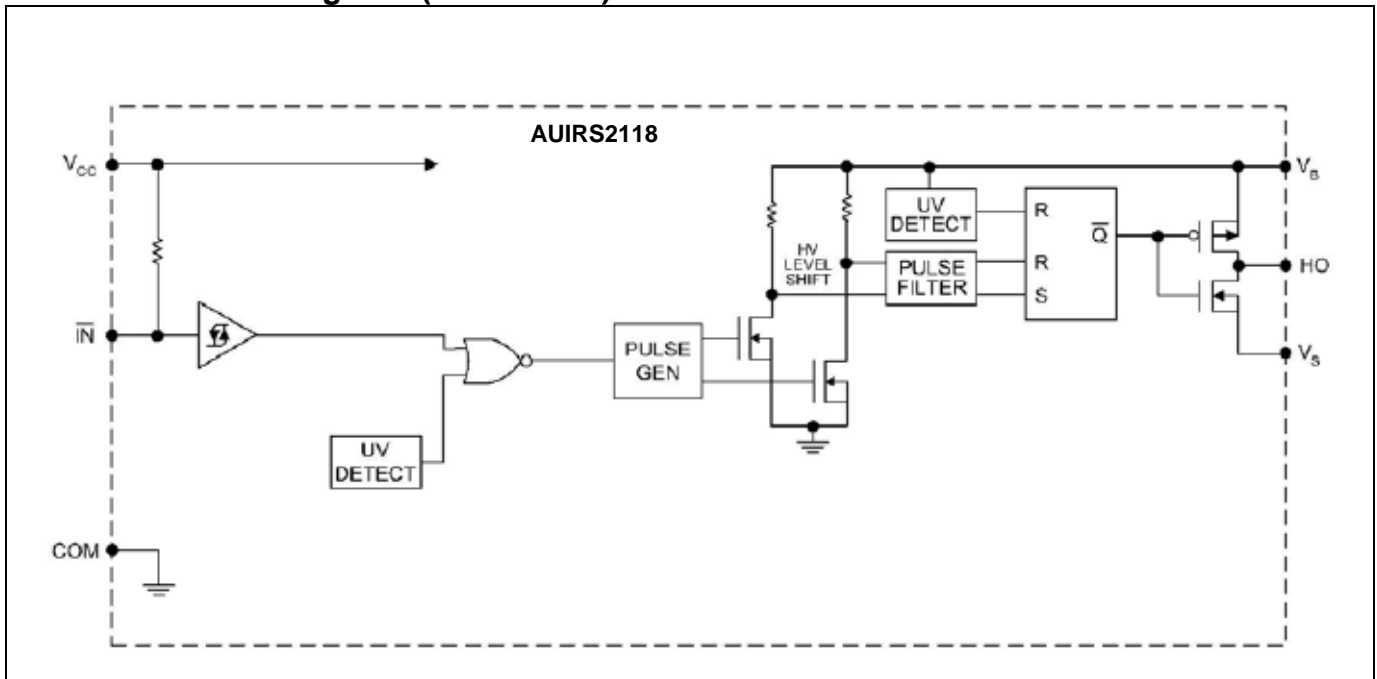

Input/Output Pin Equivalent Circuit Diagrams: AUIRS2117S

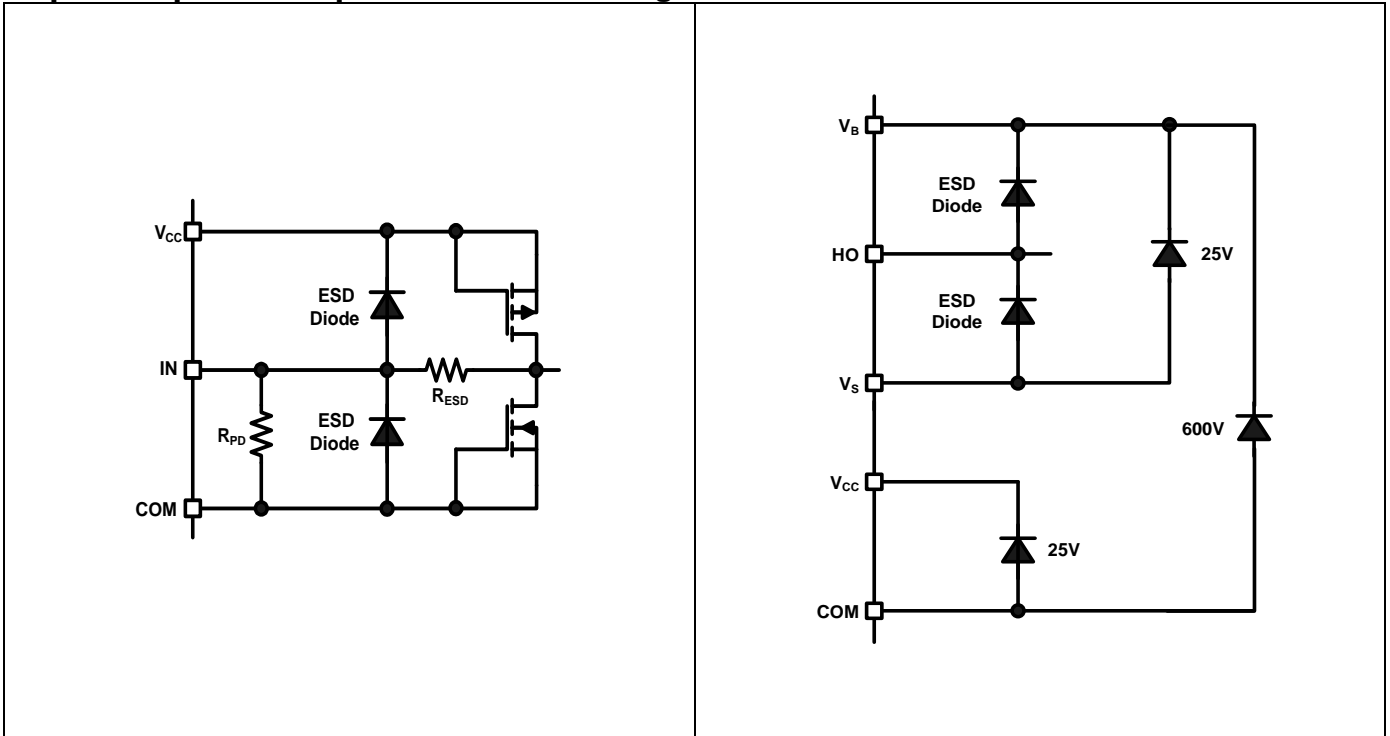

Input/Output Pin Equivalent Circuit Diagrams: AUIRS2118S

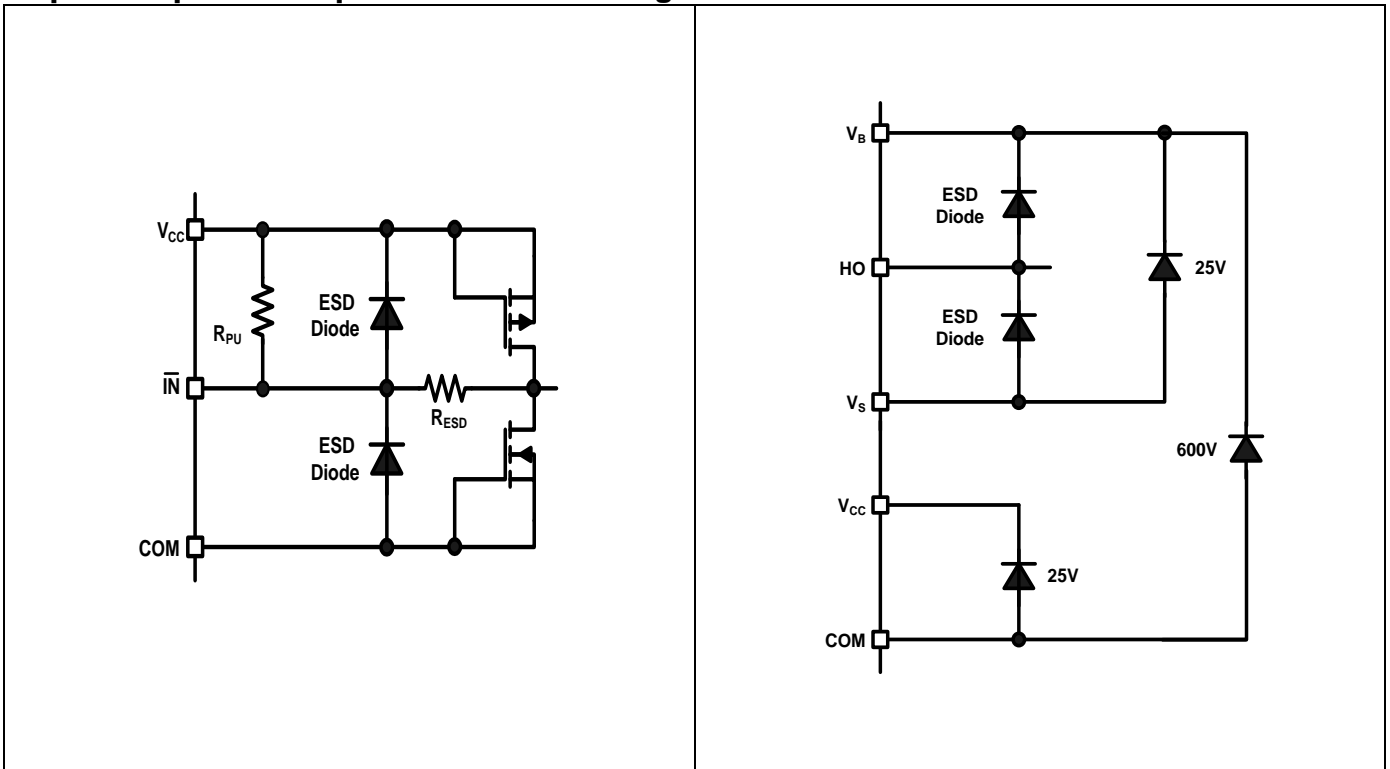

Lead Definitions

PIN	Symbol	Description
1	V _{CC}	Low-side and logic fixed supply
2	IN	Logic input for gate driver output (HO), in phase with HO (AUIRS2117)
	$\overline{\text{IN}}$	Logic input for gate driver output (HO), out of phase with HO (AUIRS2118)
3	COM	Logic ground
4	NC	No Connection
5	NC	No Connection
6	V _S	High-side floating supply return
7	HO	High-side gate drive output
8	V _B	High-side floating supply

Lead Assignments

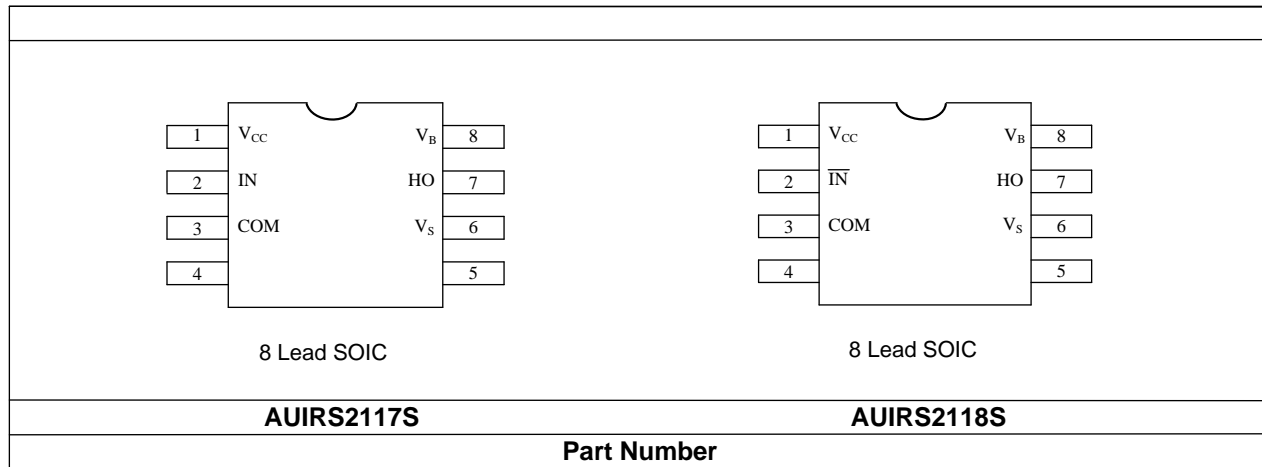

Application Information and Additional Details

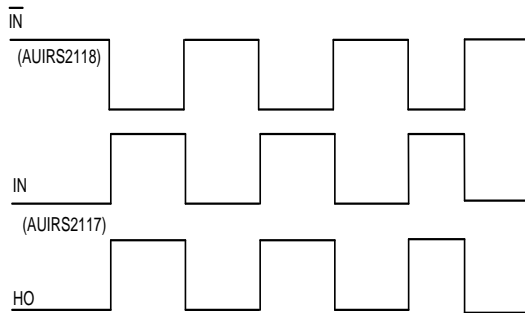

Figure 1: Input/Output Timing Diagram

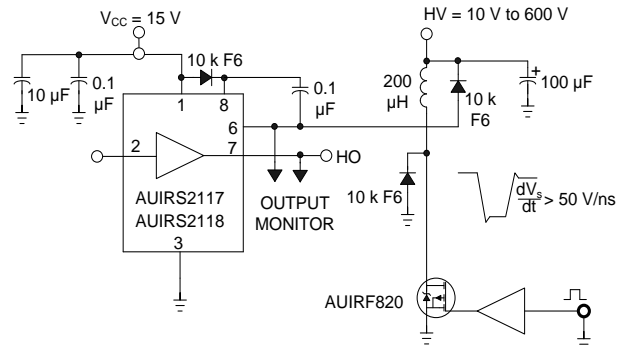

Figure 2: Floating Supply Voltage Transient Test Circuit

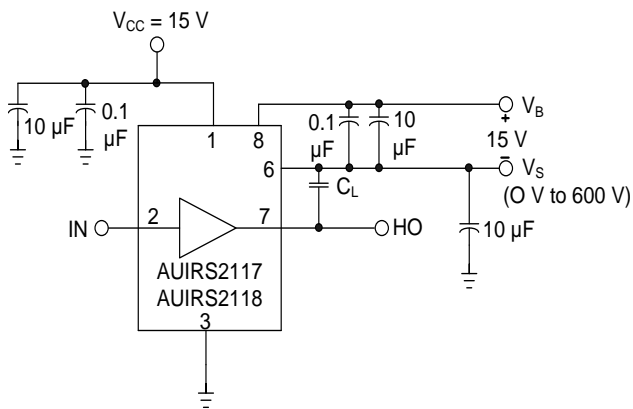

Figure 3: Switching Time Test Circuit

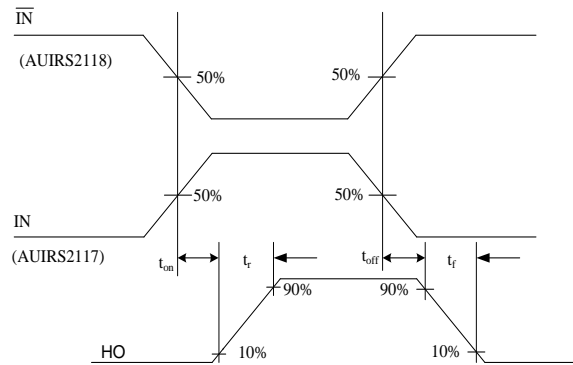

Figure 4: Switching Time Waveform Definition

Tolerant to Negative V_s Transients

A common problem in today's high-power switching converters is the transient response of the switch node's voltage as the power switches transition on and off quickly while carrying a large current. A typical half bridge circuit is shown in Figure 5; here we define the power switches and diodes of the inverter.

If the high-side switch (e.g., Q1 in Figures 6 and 7) switches off, while the current is flowing to a load, a current commutation occurs from high-side switch (Q1) to the diode (D2) in parallel with the low-side switch of the inverter. At the same instance, the voltage node V_s swings from the positive DC bus voltage to the negative DC bus voltage.

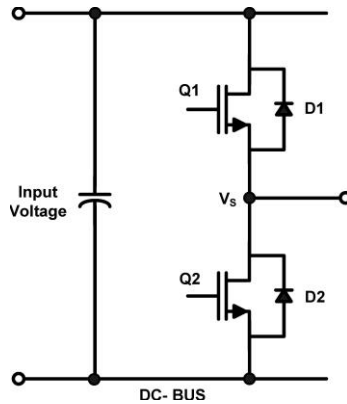

Figure 5: Half Bridge Circuit

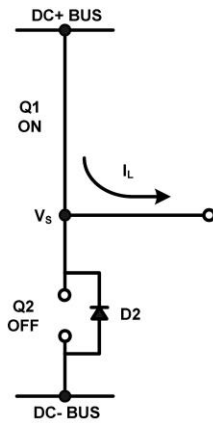

Figure 6: Q1 conducting

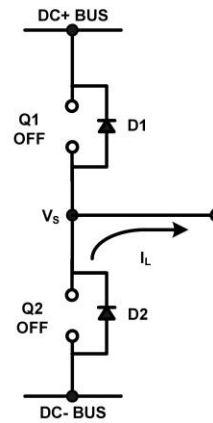

Figure 7: D2 conducting

Also when the current flows from the load back to the inverter (see Figures 8 and 9), and Q2 switches on, the current commutation occurs from D1 to Q2. At the same instance, the voltage node V_s swings from the positive DC bus voltage to the negative DC bus voltage.

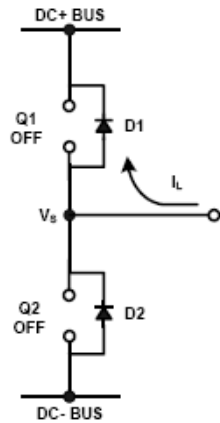

Figure 8: D1 conducting

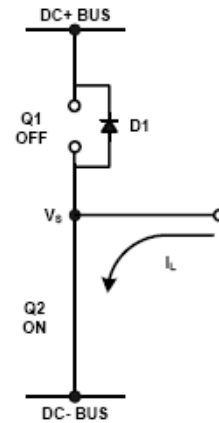

Figure 9: Q2 conducting

However, in a real inverter circuit, the V_s voltage swing does not stop at the level of the negative DC bus, rather it swings below the level of the negative DC bus. This undershoot voltage is called “negative V_s transient”.

The circuit shown in Figure 10 depicts a half bridge circuit with parasitic elements shown; Figures 11 and 12 show a simplified illustration of the commutation of the current between Q1 and D2. The parasitic inductances in the power circuit from the die bonding to the PCB tracks are lumped together in L_D and L_S for each switch. When the high-side switch is on, V_s is below the DC+ voltage by the voltage drops associated with the power switch and the parasitic elements of the circuit. When the high-side power switch turns off, the load current can momentarily flow in the low-side freewheeling diode due to the inductive load connected to V_s (the load is not shown in these figures). This current flows from the DC- bus (which is connected to the COM pin of the HVIC) to the load and a negative voltage between V_s and the DC- Bus is induced (i.e., the COM pin of the HVIC is at a higher potential than the V_s pin).

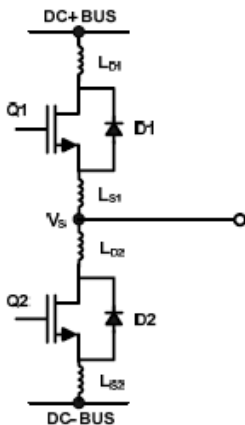

Figure 10: Parasitic Elements

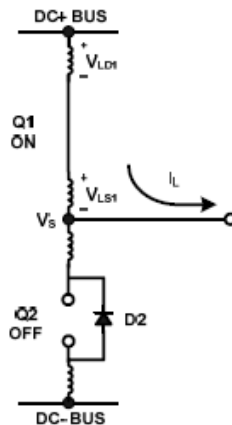

Figure 11: V_s positive

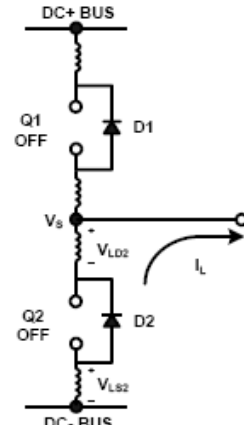

Figure 12: V_s negative

In a typical power circuit, dV/dt is typically designed to be in the range of 1-5 V/ns. The negative V_s transient voltage can exceed this range during some events such as short circuit and over-current shutdown, when di/dt is greater than in normal operation.

International Rectifier’s HVICs have been designed for the robustness required in many of today’s demanding applications. An indication of the AUIRS2117(8)s’ robustness can be seen in Figure 13, where there is represented the IRS2117(8)S Safe Operating Area at $V_{BS}=15V$ based on repetitive negative V_s spikes. A negative V_s transient voltage falling in the grey area (outside SOA) may lead to IC permanent damage; viceversa unwanted functional anomalies or permanent damage to the IC do not appear if negative V_s transients fall inside SOA.

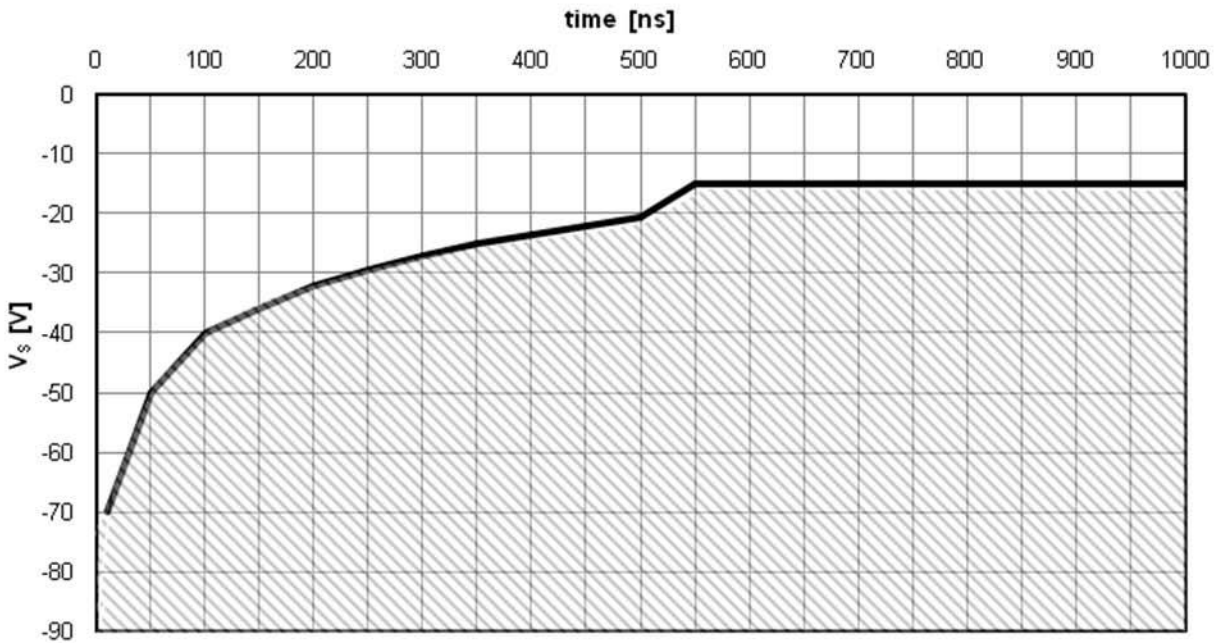

Figure 13: Negative VS transient SOA for AUIRS2117(8)S @ VBS=15V

Even though the AUIRS2117(8)S has shown the ability to handle these large negative Vs transient conditions, it is highly recommended that the circuit designer always limit the negative Vs transients as much as possible by careful PCB layout and component use.

Parameter Temperature Trends

Figures 14-28 provide information on the experimental performance of the AUIRS2117(8)S HVIC. The line plotted in each figure is generated from actual lab data. A large number of individual samples were tested at three temperatures (-40 °C, 25 °C, and 125 °C) in order to generate the experimental curve.

The line consists of three data points (one data point at each of the tested temperatures) that have been connected together to illustrate the understood trend. The individual data points on the Typ. curve were determined by calculating the averaged experimental value of the parameter (for a given temperature).

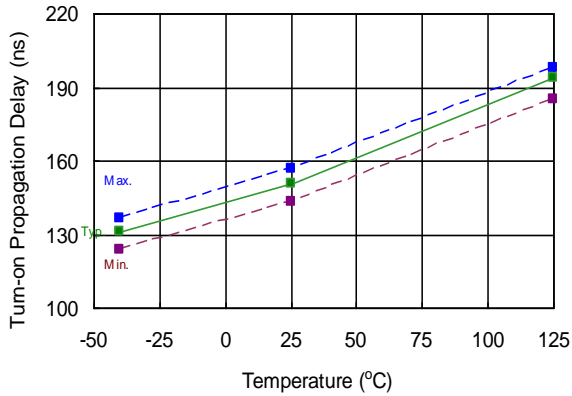

Figure 14. Turn-On Time vs. Temperature

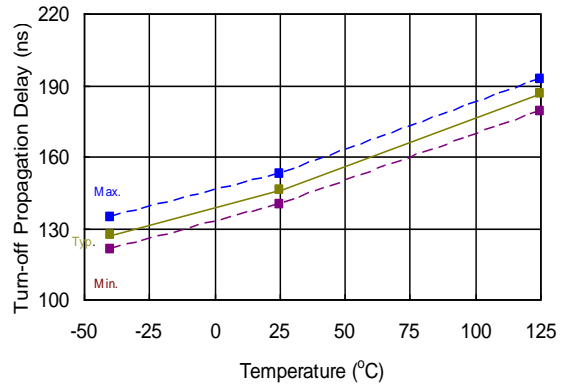

Figure 15. Turn-Off Time vs. Temperature

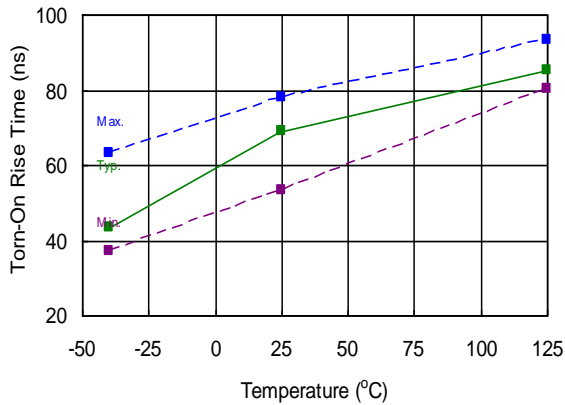

Figure 16. Turn-On Rise Time vs. Temperature

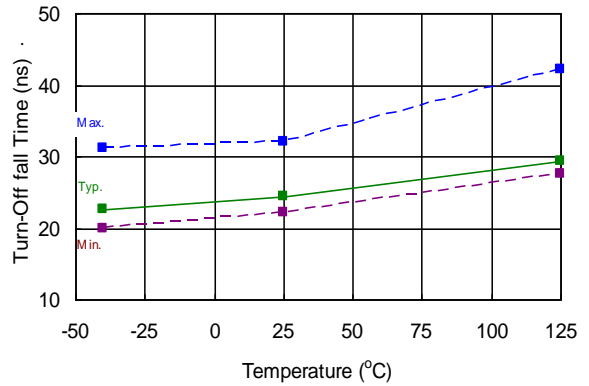

Figure 17. Turn-Off Fall Time vs. Temperature

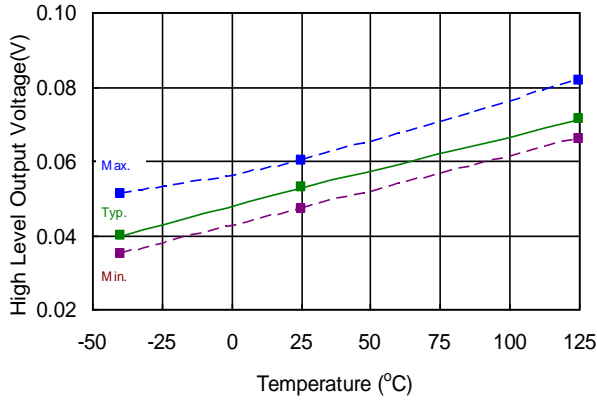

Figure 18. High Level Output Voltage vs. Temperature

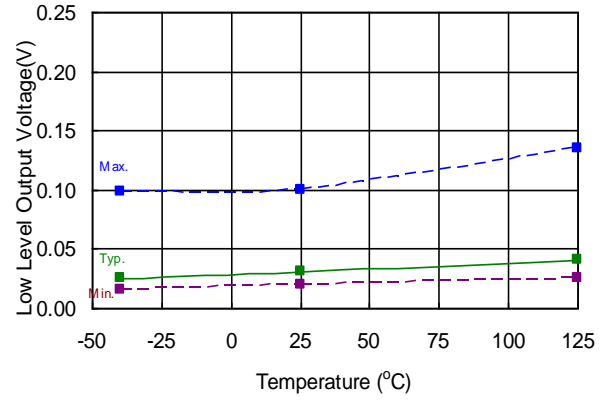

Figure 19. Low Level Output Voltage vs. Temperature

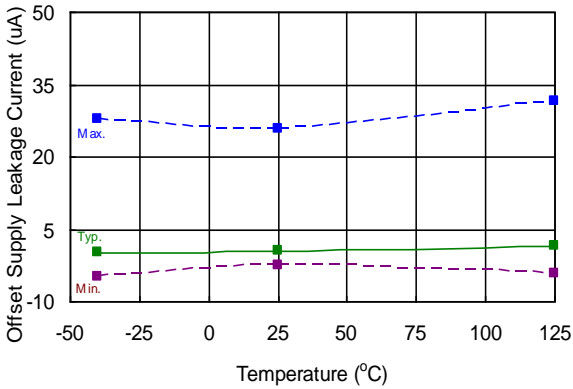

Figure 20. Offset Supply Leakage Current vs. Temperature

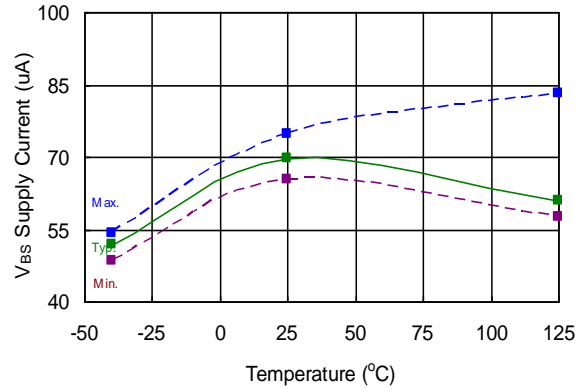

Figure 21. V_{BS} Supply Current vs. Temperature

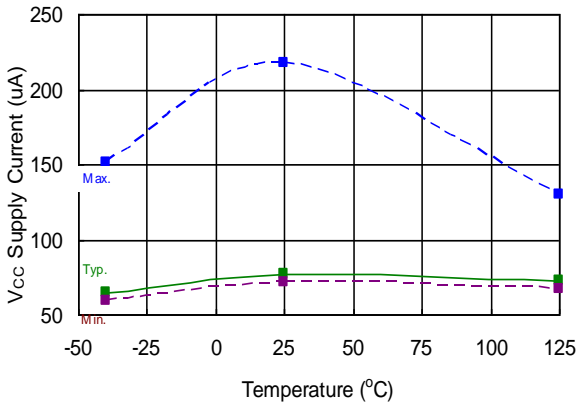

Figure 22. V_{CC} Supply Current vs. Temperature

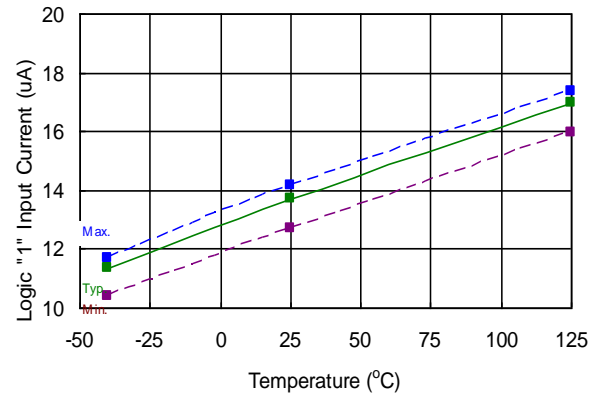

Figure 23. Logic "1" Input Current vs. Temperature

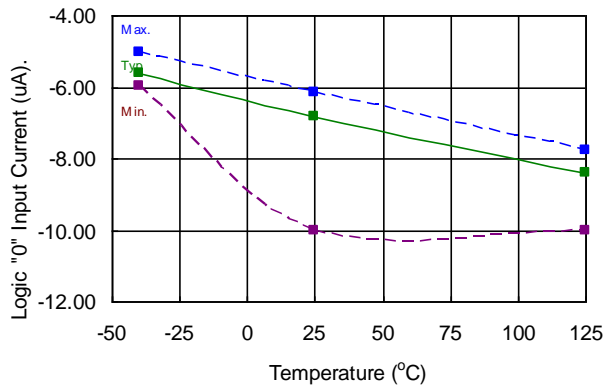

Figure 24. Logic "0" (2118 "1") Input Current vs. Temperature

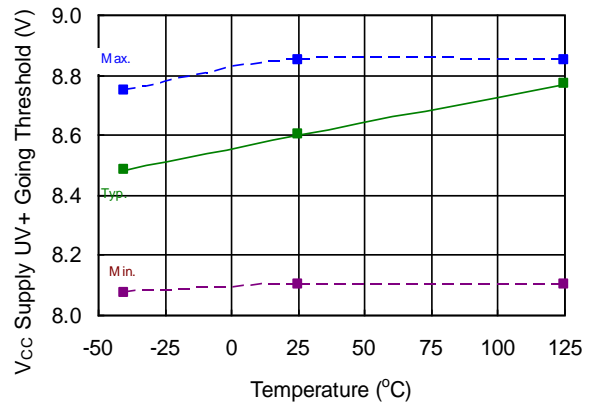

Figure 25. V_{CC} Undervoltage Threshold (+) vs. Temperature

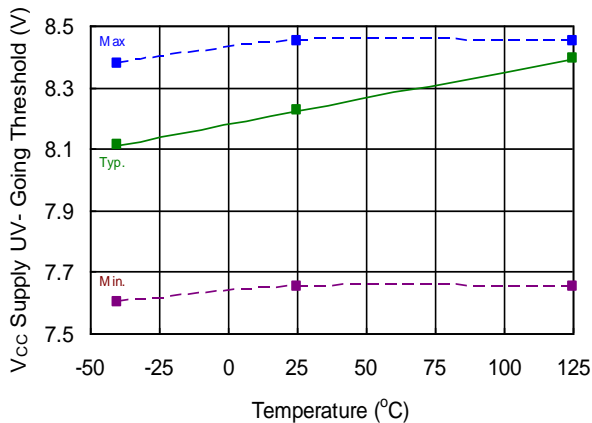

Figure 26. V_{CC} Undervoltage Threshold (-) vs. Temperature

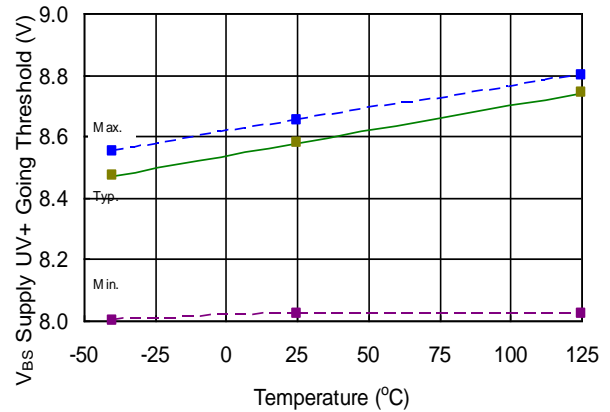

Figure 27. V_{BS} Undervoltage Threshold (+) vs. Temperature

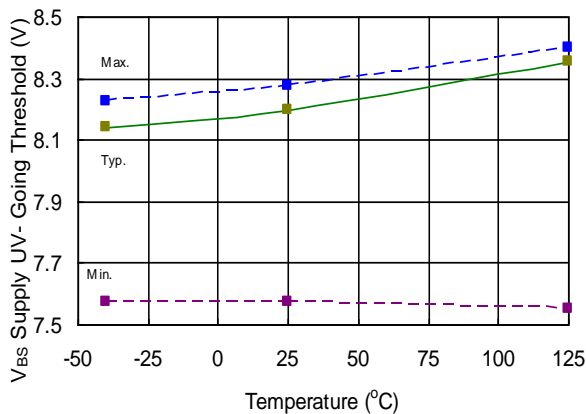
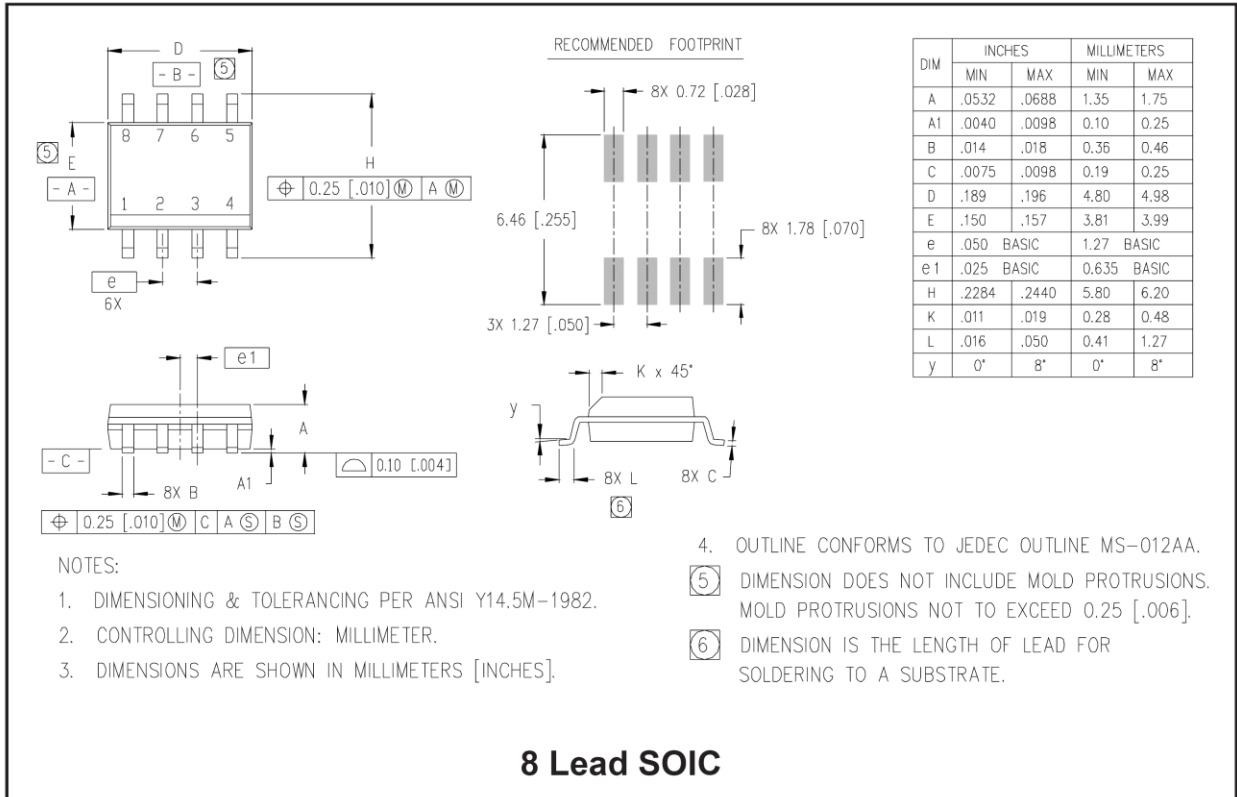
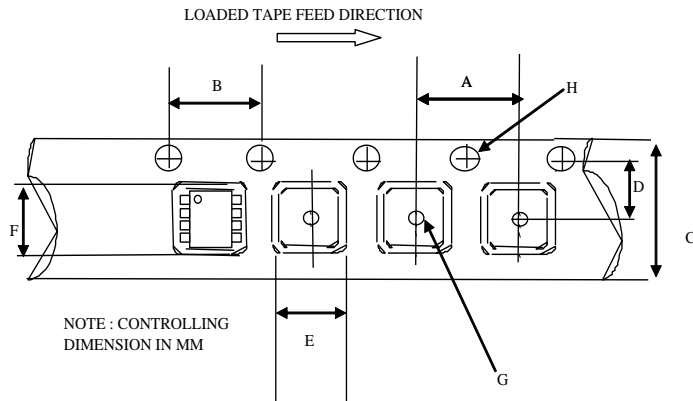

Figure 28. V_{BS} Undervoltage Threshold (-) vs. Temperature

Package Details: SOIC8



Tape and Reel Details: SOIC8



CARRIER TAPE DIMENSION FOR 8SOICN

Code	Metric		Imperial	
	Min	Max	Min	Max
A	7.90	8.10	0.311	0.318
B	3.90	4.10	0.153	0.161
C	11.70	12.30	0.46	0.484
D	5.45	5.55	0.214	0.218
E	6.30	6.50	0.248	0.255
F	5.10	5.30	0.200	0.208
G	1.50	n/a	0.059	n/a
H	1.50	1.60	0.059	0.062

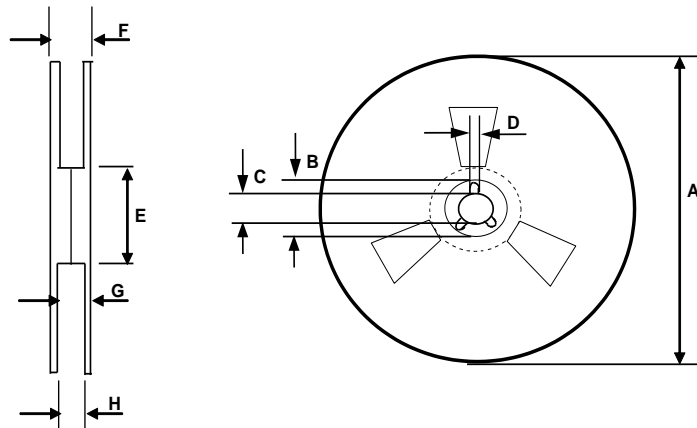

REEL DIMENSIONS FOR 8SOICN

Code	Metric		Imperial	
	Min	Max	Min	Max
A	329.60	330.25	12.976	13.001
B	20.95	21.45	0.824	0.844
C	12.80	13.20	0.503	0.519
D	1.95	2.45	0.767	0.096
E	98.00	102.00	3.858	4.015
F	n/a	18.40	n/a	0.724
G	14.50	17.10	0.570	0.673
H	12.40	14.40	0.488	0.566

Part Marking Information

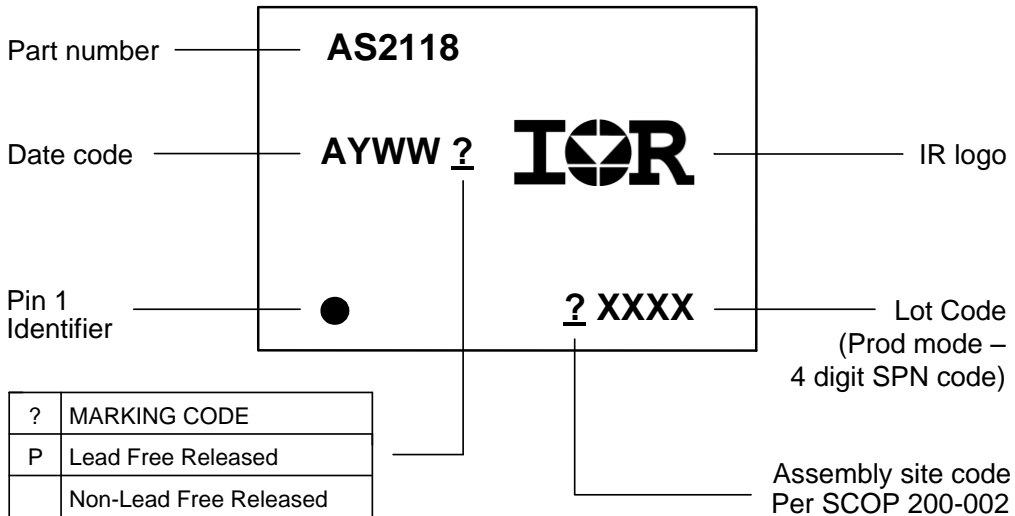
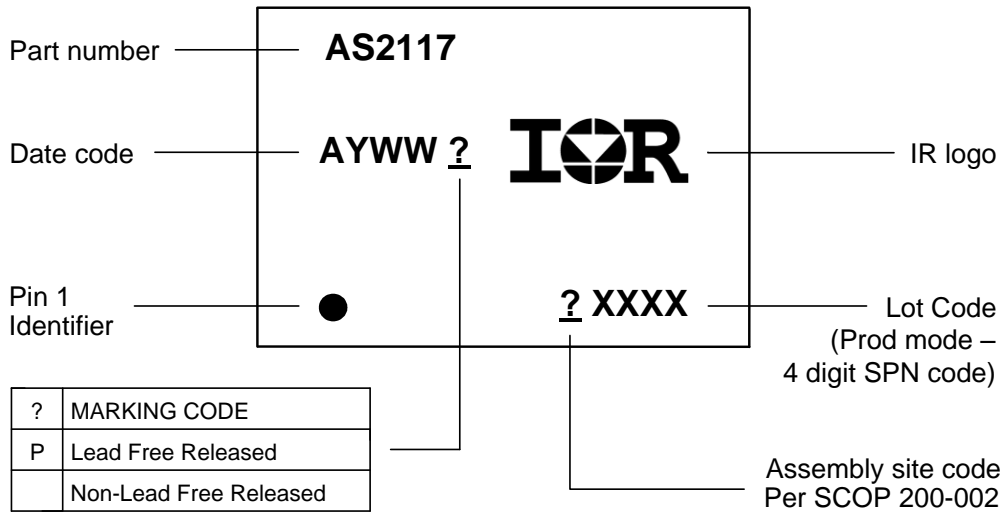

Ordering Information

Base Part Number	Package Type	Standard Pack		Complete Part Number
		Form	Quantity	
AUIRS2117S	SOIC8	Tube/Bulk	95	AUIRS2117S
		Tape and Reel	2500	AUIRS2117STR
AUIRS2118S	SOIC8	Tube/Bulk	95	AIRS2118S
		Tape and Reel	2500	AUIRS2118STR

IMPORTANT NOTICE

Unless specifically designated for the automotive market, International Rectifier Corporation and its subsidiaries (IR) reserve the right to make corrections, modifications, enhancements, improvements, and other changes to its products and services at any time and to discontinue any product or services without notice. Part numbers designated with the “AU” prefix follow automotive industry and / or customer specific requirements with regards to product discontinuance and process change notification. All products are sold subject to IR’s terms and conditions of sale supplied at the time of order acknowledgment.

IR warrants performance of its hardware products to the specifications applicable at the time of sale in accordance with IR’s standard warranty. Testing and other quality control techniques are used to the extent IR deems necessary to support this warranty. Except where mandated by government requirements, testing of all parameters of each product is not necessarily performed.

IR assumes no liability for applications assistance or customer product design. Customers are responsible for their products and applications using IR components. To minimize the risks with customer products and applications, customers should provide adequate design and operating safeguards.

Reproduction of IR information in IR data books or data sheets is permissible only if reproduction is without alteration and is accompanied by all associated warranties, conditions, limitations, and notices. Reproduction of this information with alterations is an unfair and deceptive business practice. IR is not responsible or liable for such altered documentation. Information of third parties may be subject to additional restrictions.

Resale of IR products or serviced with statements different from or beyond the parameters stated by IR for that product or service voids all express and any implied warranties for the associated IR product or service and is an unfair and deceptive business practice. IR is not responsible or liable for any such statements.

IR products are not designed, intended, or authorized for use as components in systems intended for surgical implant into the body, or in other applications intended to support or sustain life, or in any other application in which the failure of the IR product could create a situation where personal injury or death may occur. Should Buyer purchase or use IR products for any such unintended or unauthorized application, Buyer shall indemnify and hold International Rectifier and its officers, employees, subsidiaries, affiliates, and distributors harmless against all claims, costs, damages, and expenses, and reasonable attorney fees arising out of, directly or indirectly, any claim of personal injury or death associated with such unintended or unauthorized use, even if such claim alleges that IR was negligent regarding the design or manufacture of the product.

IR products are neither designed nor intended for use in military/aerospace applications or environments unless the IR products are specifically designated by IR as military-grade or “enhanced plastic.” Only products designated by IR as military-grade meet military specifications. Buyers acknowledge and agree that any such use of IR products which IR has not designated as military-grade is solely at the Buyer’s risk, and that they are solely responsible for compliance with all legal and regulatory requirements in connection with such use.

IR products are neither designed nor intended for use in automotive applications or environments unless the specific IR products are designated by IR as compliant with ISO/TS 16949 requirements and bear a part number including the designation “AU”. Buyers acknowledge and agree that, if they use any non-designated products in automotive applications, IR will not be responsible for any failure to meet such requirements.

For technical support, please contact IR’s Technical Assistance Center
<http://www.irf.com/technical-info/>

WORLD HEADQUARTERS:
 101 N. Sepulveda Blvd., El Segundo, California 90245
 Tel: (310) 252-7105