

AVR-P28 development board

Users Manual



All boards produced by Olimex are ROHS compliant

Revision A, November 2005
Copyright(c) 2009, OLIMEX Ltd, All rights reserved

INTRODUCTION:

The **AVR Microcontrollers** are low-power CMOS 8-bit controller based on the RISC architecture. The AVR core combines a rich instruction set with general purpose working registers. All the registers are directly connected to the Arithmetic Logic Unit (ALU), allowing two independent registers to be accessed in one single instruction executed in one clock cycle. The resulting architecture is more code efficient while achieving throughputs up to ten times faster than conventional CISC microcontrollers.

AVR-P28 is prototype board for 28 pin AVR microcontrollers with STKxxx compatible 10 pin ICSP connector.

BOARD FEATURES:

- ICSP 5x2 pin connector for in-circuit programming with AVR-PG1B or AVR-PG2B
- RS232 Tx, Rx interface with MAX232 IC on socket
- power supply filtering capacitors
- 8MHz crystal on socket
- reset IC ZM33064
- reset button
- general purpose push button
- status LED connected via removable jumper
- DIL28 microcontroller socket
- extension pin headers for each uC pin
- four mounting holes 3.3 mm (0.13")
- FR-4, 1.5 mm (0,062"), green soldermask, white silkscreen component print
- dimensions 100x80 mm (3.9x3.15")

ELECTROSTATIC WARNING:

The AVR-P28 board is shipped in protective anti-static packaging. The board must not be subject to high electrostatic potentials. General practice for working with static sensitive devices should be applied when working with this board.

BOARD USE REQUIREMENTS:

Cables: The cable you will need depends on the programmer/debugger you use. If you use [AVR-PG1](#), you will need RS232 cable, if you use [AVR-PG2](#), you will need LPT cable, if you use [AVR-ISP500](#), [AVR-ISP500-TINY](#) or [AVR-ISP500-ISO](#), you will need 1.8 meter USB A-B cable.

Hardware: Programmer - one of the Olimex AVR Programmers: AVR-PG1, AVR-PG2, AVR-ISP500, AVR-ISP500-TINY, AVR-ISP500-ISO.

SCHEMATIC:

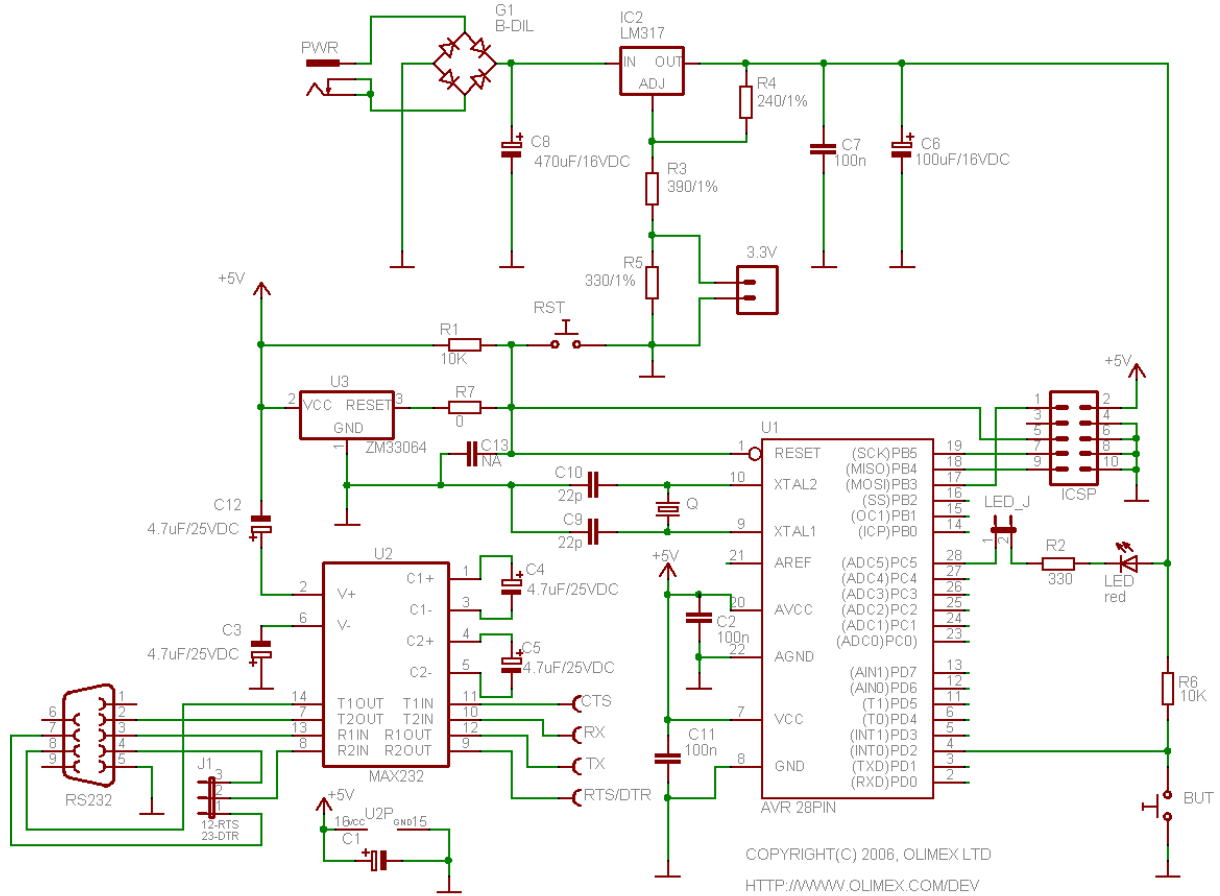

BOARD LAYOUT:

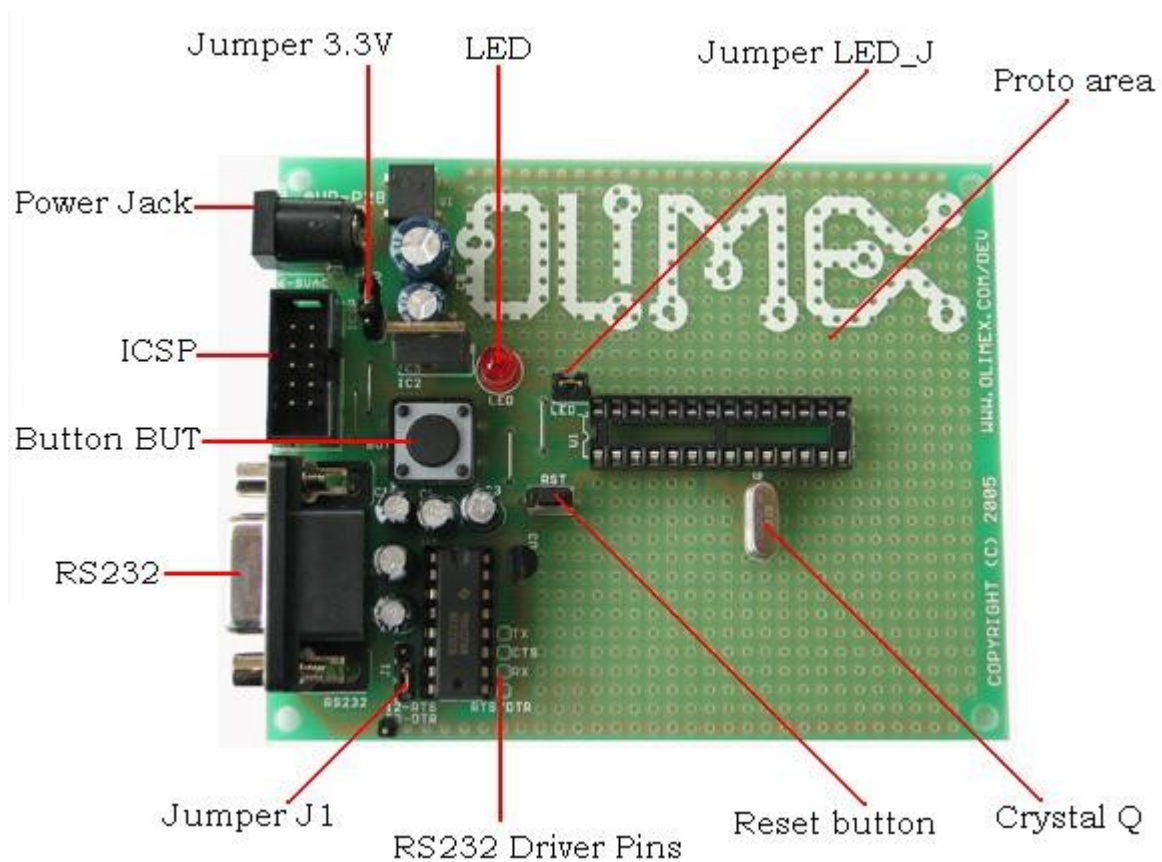

POWER SUPPLY CIRCUIT:

AVR-P28 is typically power supplied with min 9.0V DC max 12.0V DC, or min 6.0V AC max 9.0V AC.

RESET CIRCUIT:

AVR-P28 reset circuit includes pin 5 of ICSP connector, pin 1 of U1, Reset scheme - U3 and RESET button (RST).

CLOCK CIRCUIT:

Quartz crystal 8MHz is connected to AVR Microcontroller pin 9 (XTAL1) and pin 10 (XTAL2).

JUMPER DESCRIPTION:

J1

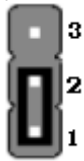

When 1-2 are shorted - RTS is connected to terminal pin RTS/DTR.
When 2-3 are shorted - DTR is connected to terminal pin RTS/DTR.
Default state is 1-2.

LED_J



When this jumper is open - LED is not connected.
When this jumper is closed - LED is connected to pin 28 (PC5/ ADC5) of the Microcontroller.
Default state is closed.

3.3V



When this jumper is open - LM317 output is 5V DC.
When this jumper is closed - LM317 output is 3.3V DC.
Default state is open.

WARNINGS!!!

1. The 3.3V jumper selects the power voltage to be 5V (open) or 3.3V (closed). MAX232 can operate only at 5V power supply so if you are working with 3.3V you should replace it with MAX3232 which works at 3.3V power supply.

2. If you want to operate with 3,3V power supply, remove R7 resistor.

INPUT/OUTPUT:

Status Led with name **LED (red)** - this led is connected to PIN28 (PC5/ ADC5) via jumper LED_J.

User button with name **BUT** - connected to PIN4 (PD2 / INT0).

Reset button with name **RST** - connected to PIN1 (RESET).

CONNECTOR DESCRIPTIONS:

ICSP:

PIN #	Signal Name	Functionality
1	MOSI	PB3 / MOSI
2	+5V DC	Supply
3	Not connected	-
4	GND	Ground
5	Reset	RESET
6	GND	Ground
7	SCK	PB5 / SCK
8	GND	Ground
9	MISO	PB4 / MISO
10	GND	Ground

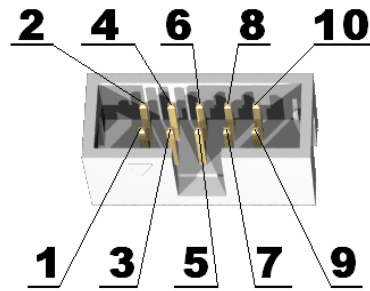

RS232:

PIN #	Signal Name
1	Not connected
2	RXD
3	TXD
4	DTR
5	GND
6	Not connected
7	RTS
8	CTS
9	Not connected

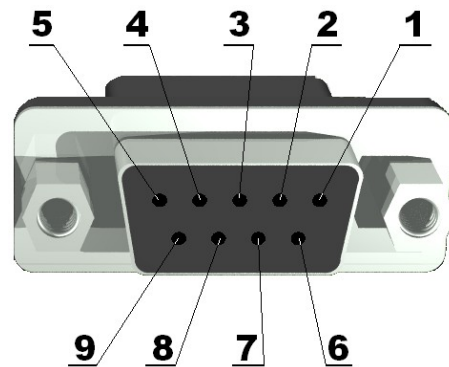

Note1: RTS and DTR is connected to terminal pins via jumper J1, which position was described above.

Note2: RX RS232 driver pins have to be connected to AVR microcontroller pin - TXD/PD1 (PIN 3).
TX RS232 driver pins have to be connected to AVR microcontroller pin - RXD/PD0 (PIN 2).

PWR:

PIN #	Signal Name
1	Power Input
2	GND

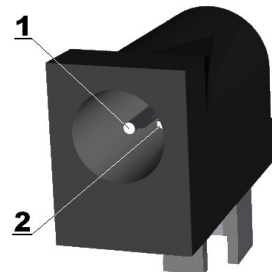

MECHANICAL DIMENSIONS:

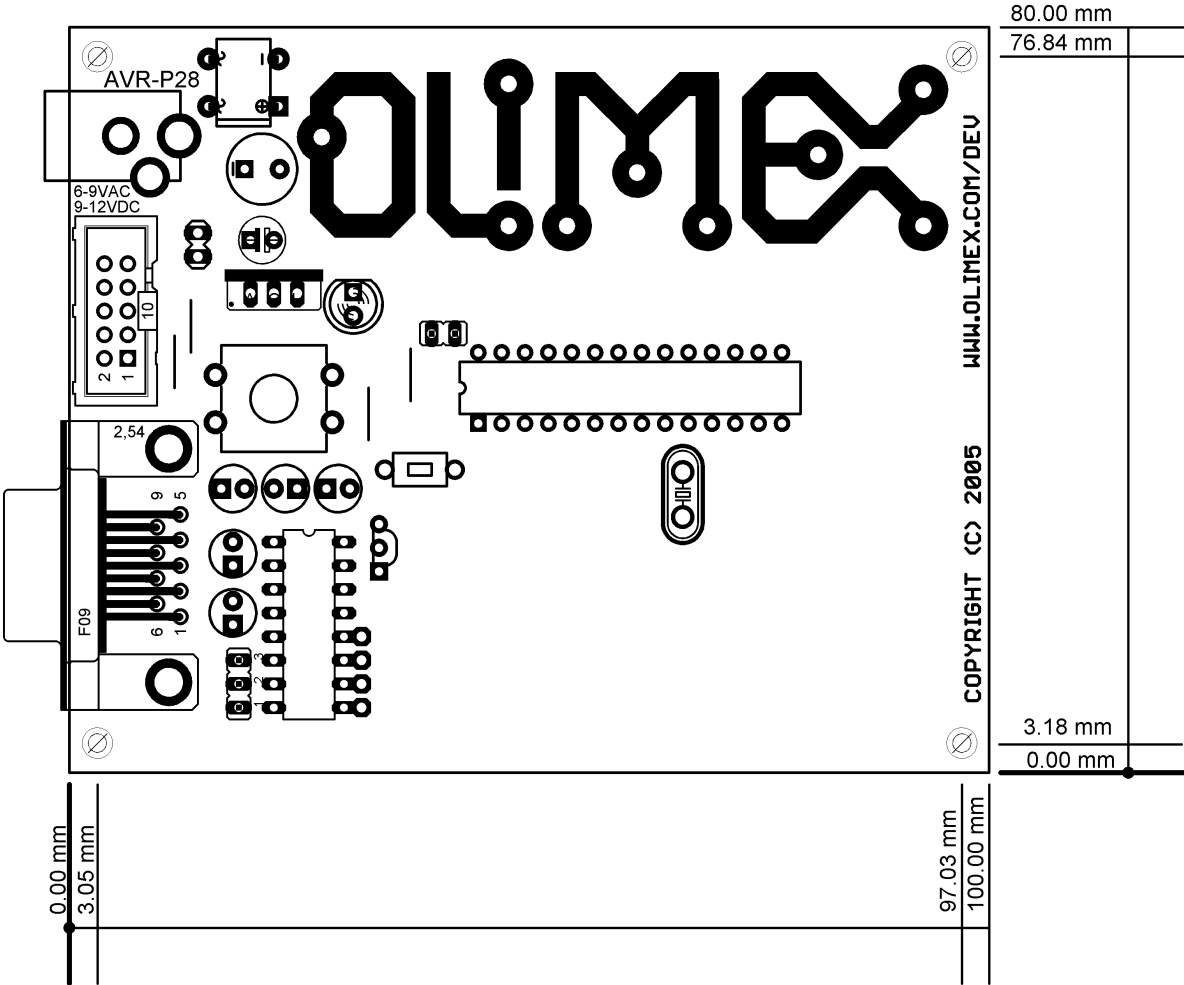

AVAILABLE DEMO SOFTWARE:

- AVR-P28 + ATmega8 Blinkng LED ([C source](#) and [HEX](#))
- AVR-P28 + ATmega8 UART demo ([C source](#) and [HEX](#))
- AVR-P28 + ATmega8 Button demo ([C source](#) and [HEX](#))

ORDER CODE:

AVR-P28-8MHz completely assembled and tested with 8Mhz oscillator
AVR-P28/PCB ONLY

How to order?

You can order to us directly or by any of our distributors.

Check our web www.olimex.com/dev for more info.

Revision history:

REV.A - created November 2005