

Airflow Sensors

Microbridge Mass Airflow/Unamplified

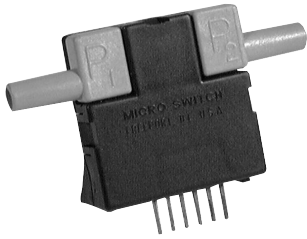

FEATURES

- Cost-effective microbridge technology
- Accurate, repeatable airflow sensing
- Bi-directional sensing capability
- Low differential pressure sensing

Take advantage of microbridge mass flow sensor technology. The AWM1000 series mass flow sensor provides all of the outstanding performance benefits of the standard AWM2000 series in a more cost-effective sensor platform. This device provides accurate, repeatable flow sensing. Sensor to sensor interchangeability specifications are approximately twice as large as compared to the AWM2000 series.

The heater control circuit in Figure 1 and the sensing bridge supply circuit in Figure 2 are both required for operation per specification. These two circuits are **NOT** on board the sensor and must be supplied in the application. The differential amplifier circuitry in Figure 3 may be useful in providing output gain and/or introducing voltage offsets to the sensor output (Ref. Equation 1).

NOTE: For applications involving sensing hydrogen (H₂) gas or helium (He) gas, see Application Note 3, page 131.

Figure 1
Heater Control Circuit

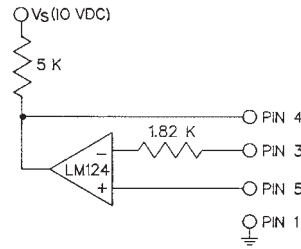

Figure 2
Sensing Bridge Supply Circuit

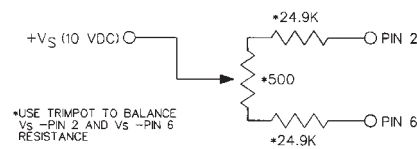
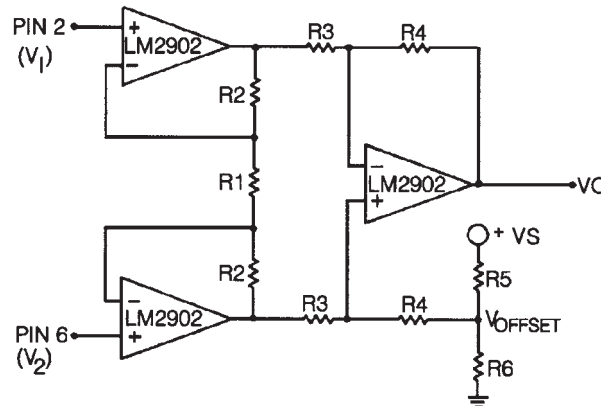

Figure 3
Differential Instrumentation Amplifier Circuit



Equation 1:

$$V_o = \left(\frac{2R_2 + R_1}{R_1} \right) \left(\frac{R_4}{R_3} \right) (V_2 - V_1) + V_{\text{offset}}$$

$$\text{where } V_{\text{offset}} = V_s \left(\frac{R_6}{R_5 + R_6} \right)$$



Airflow Sensors

Microbridge Mass Airflow/Unamplified

AWM1000 Series

AWM1000 SERIES ORDER GUIDE (Performance Characteristics @ 10.0 ±0.01 VDC, 25°C)

Catalog Listings	AWM1100V	AWM1200V	AWM1300V
Flow Range (Full Scale)	±200 sccm		+1000 sccm to -600 sccm
Pressure Range (See Application Note #1)		±4.0" H ₂ O (10 mBar)	
Output Voltage @ Trim Point	30 mV @ 100 sccm	20 mV @ 2.0" H ₂ O	50 mV @ 650 sccm
Null Voltage Shift, Typ. +25 to -25°C, +25 to 85°C	±0.7 mV (max.)	±0.7 mV (max.)	±0.7 mV (max.)
Output Voltage Shift, Max. +25 to -25°C +25 to +85°C	±4% Full Scale ±4% Full Scale	+22% Reading (Note 2) -22% Reading	±4% Full Scale ±4% Full Scale
Repeatability & Hysteresis, Max.	±1% Full Scale	±1% Full Scale	±1% Full Scale
	Min.	Typ.	Max.
Excitation (VDC) (Note 1)	8.0	10±0.01	15
Power Consumption (mW)	—	30	50
Null Voltage (mV)	-1.0	0.0	+1.0
Response Time (msec)	—	1.0	3.0
Common Mode Pressure (psi)	—	—	25
Sensor Resistance (kΩ) Pin 2-Pin 1, Pin 6-Pin 1	—	5	—
Sensor Current (mA) Pin 2-Pin 1, Pin 6-Pin 1	—	0.3	0.6
Temperature Range	Operating: -25° to +85°C (-13° to +185°F); Storage: -40° to +90°C (-40° to +194°F)		
Termination	2,54 mm (.100") centers, 0,635 mm (0.025") square		
Weight (grams)	10.8		
Shock Rating	100 g peak (5 drops, 6 axes)		

- Notes:**
- Output Voltage is ratiometric to supply voltage.
 - Temperature shifts when sensing differential pressure correlates to the density change of the gas over temperature. See Application Note 1.
 - Maximum allowable rate of flow change to prevent damage: 5 SLPM/1.0 sec.

MOUNTING DIMENSIONS (for reference only)

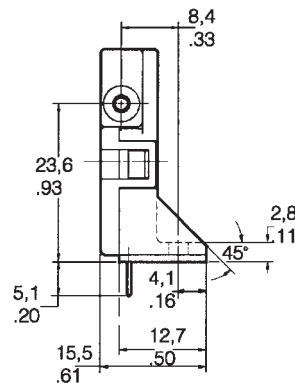
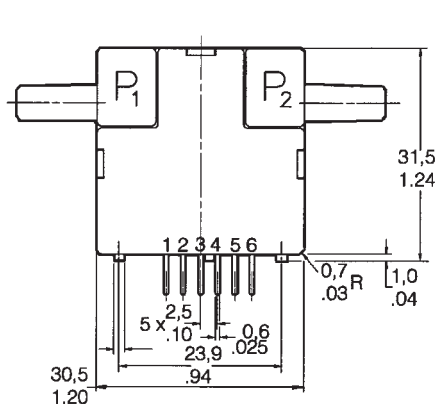
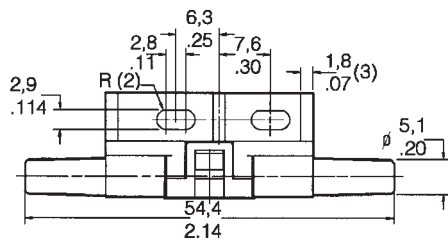

NOTE: Positive flow direction is defined as proceeding from Port 1 (P1) to Port 2 (P2) and results in positive output (Pin 6 > Pin 2). Negative flow direction is defined conversely and results in negative output (Pin 6 < Pin 2). Do not exert a force greater than 4.54 kg (10 lbs.) in any direction.