

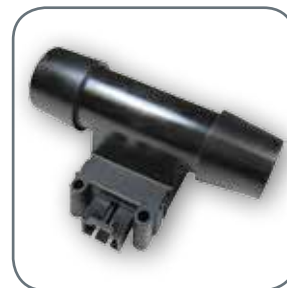

**Airflow Sensors**  
**AWM700 Series, Compensated/Amplified**



# Airflow Sensors

The AWM700 Series, Compensated/Amplified Airflow Sensors provide in-line flow measurement with a specially designed bypass flow housing. These sensors measure flow as high as 300 standard liters per minute (SLPM) while inducing a typical pressure drop of 1 inH<sub>2</sub>O.

The AWM700 has a high flow range capability in a small package, as well as a 6 ms response time. These sensors require a 10 Vdc supply, but consume only 60 mW of power.

The compact plastic package withstands overpressures of 1720 mbar | 172 kPa | 25 psi without compromising performance. The snap-in AMP-compatible connector provides reliable connection.

The AWM700 Series provides a combination of time-proven reliability, high accuracy, and precision operating characteristics. This inherent accuracy over life reduces need for recalibration. AWM700 sensor circuitry performs amplification and temperature compensation.

The AWM720P1 and AWM730B5 were developed primarily for the medical ventilation market and meet the high performance requirements of many medical and analytical instrumentation applications.

## Key Features and Benefits

- **Flow tubes for ranges up to 300 SLPM:** Provides low pressure drop in the customer's application
- **Highly stable null and full scale:** Does not require recalibration in most applications
- **Compact package design:** Occupies less space in the customer's enclosure, potentially reducing production costs; enclosure size may also be reduced for easier fit into space-constrained applications
- **Low hysteresis and repeatability errors (less than 0.35% of reading):** Provides better system accuracy
- **Enhanced response flow time of 6 ms:** Captures full flow event
- **Low power consumption:** Allows for use in portable devices and battery-powered applications

## Potential Applications

### MEDICAL

- Oxygen concentrators and conservers
- Respirators and ventilators
- Nebulizers
- Continuous positive airway pressure (CPAP)
- Anesthesia machines

### INDUSTRIAL

- Mass flow controllers
- Telecommunication systems
- Environmental climate controls
- Fuel cell controls
- Process gas control welding equipment and lasers

HIGHLY STABLE • COMPACT PACKAGE • LOW HYSTERESIS

# AWM700 Series, Compensated/Amplified

Table 1. Specifications

Characteristic	Parameter	
	AWM720P1	AWM730B5
		
Flow range	+200 SLPM	±300 SLPM
Excitation voltage <sup>1</sup>	10 Vdc ±0.01 Vdc	5 Vdc ±0.01 Vdc
Power supply	8.0 Vdc min./10.0 Vdc typ./15.0 Vdc max.	9.0 Vdc min./16.0 Vdc max.
Power consumption	60 mW	
Output loading: sinking sourcing	10 mA typ. 20 mA typ.	
Calibration gas	air	
Null voltage shift: 25 °C to -25 °C [77 °F to -13 °F] 25 °C to 85 °C [77 °F to 185 °F]  25 °C to 5 °C [77 °F to 41 °F] 25 °C to 60 °C [77 °F to 140 °F]	±0.025 Vdc typ. ±0.025 Vdc typ.  — —	— —  ±0.02 Vdc typ. ±0.02 Vdc typ.
Full scale output shift: 25 °C to 10 °C [77 °F to 50 °F] 25 °C to 40 °C [77 °F to 104 °F]  25 °C to 5 °C [77 °F to 41 °F] 25 °C to 60 °C [77 °F to 140 °F]	-2.0 Vdc %reading typ. +2.0 Vdc %reading typ.  — —	— —  ±2.5 %reading typ. ±2.5 %reading typ.
Ratiometricity error <sup>1</sup>	±0.30 %reading typ.	—
Repeatability and hysteresis <sup>2</sup>	±0.50 %reading max.	±0.035 Vdc typ.
Response time <sup>3</sup>	6 ms typ.	10 ms typ.
Warmup time	—	5 s
Pressure drop at full scale	2,5 mbar   250 Pa   1.0 inH <sub>2</sub> O typ.	3,0 mbar   300 Pa   1.2 inH <sub>2</sub> O typ.
Overpressure	1720 mbar   172 kPa   25 psi max.	1034 mbar   103 kPa   15 psi max.
Temperature range: operating storage	-25 °C to 85 °C [-13 °F to 185 °F] -40 °C to 90 °C [-40 °F to 194 °F]	5 °C to 60 °C [41 °F to 140 °F] -40 °C to 90 °C [-40 °F to 194 °F]
Orientation sensitivity	—	<0.005 Vdc typ. variation at 5 Vdc excitation between any two directions
Weight	34 g [1.20 oz]	23,2 g [0.75 oz]
Connector	snap-in AMP 103956-3 provided with sensor	

<sup>1</sup>Output voltage is ratiometric to supply voltage.

<sup>2</sup>Repeatability and hysteresis tolerances reflect inherent inaccuracies of the measurement equipment.

<sup>3</sup>Response times are from 10% to 90%.

# AWM700 Series, Compensated/Amplified

Table 2. AWM720P1 Flow Specifications

Flow (SLPM)	Nominal (Vdc)	Tolerance (Vdc)	Pressure Drop		
			(mbar)	(Pa)	(inH <sub>2</sub> O)
0	1.00	±0.05	0	0	0
25	2.99	—	0.10	10	0.04
50	3.82	±0.18	0.33	33	0.13
75	4.30	—	0.53	53	0.21
100	4.58	—	0.85	85	0.34
150	4.86	—	1.64	164	0.65
200	5.00	±0.36	2.74	274	1.09

Table 3. AWM730B5 Flow Specifications

Flow (SLPM)	Nominal (Vdc)	Tolerance (Vdc)	Pressure Drop		
			(mbar)	(Pa)	(inH <sub>2</sub> O)
0	2.500	±0.090	—	—	—
100	3.600	±0.180	—	—	—
200	4.150	±0.180	—	—	—
300	4.500	±0.360	2.94	294	1.18

# AWM700 Series, Compensated/Amplified

Figure 1. Mounting Dimensions (For reference only: mm/[in.] )

## AWM720P1

### Pinout

- 1: NC
- 2: V-
- 3: +10 Vdc
- 4: Vout

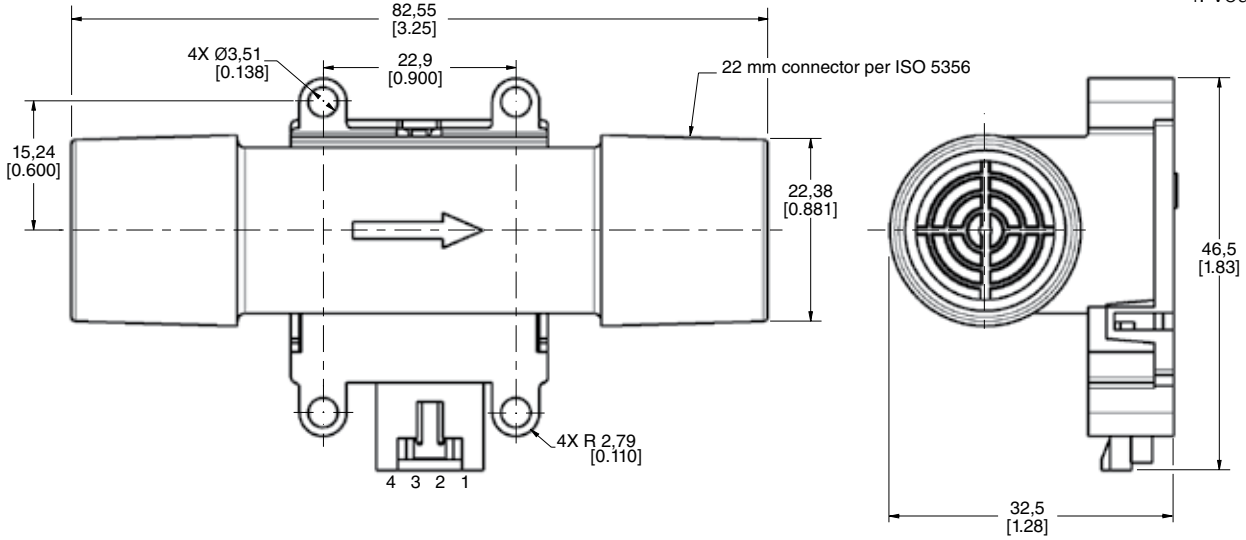

## AWM730B5

### Pinout

- 1: +15 Vdc
- 2: Gnd
- 3: 5 Vdc
- 4: Vout

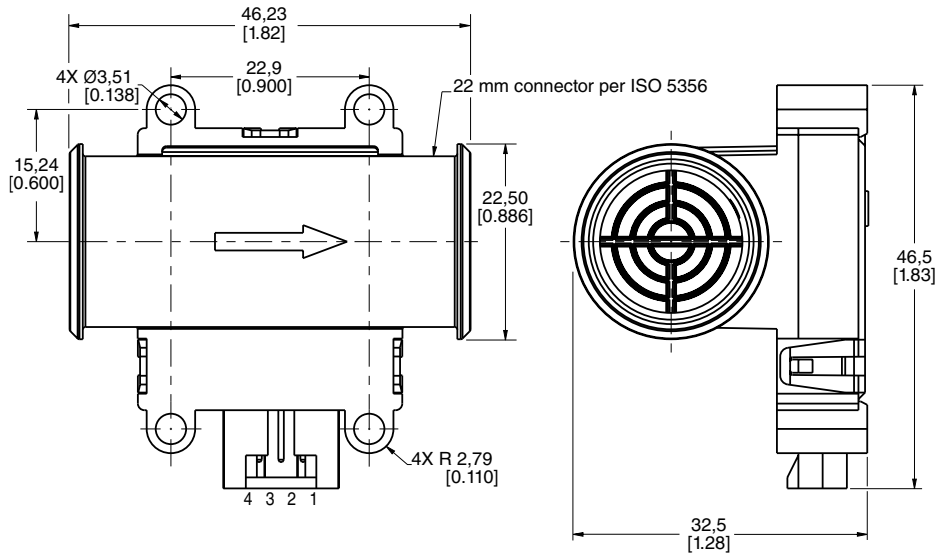

# AWM700 Series, Compensated/Amplified

## LAMINAR FLOW

Due to the fast response time of the sensor, the specifications in this datasheet were generated using laminar flow. Airflow instability or “turbulence” present in the airstream will result in an increase in measurement uncertainty. Turbulent flow may be corrected by either of the following two methods:

- Straightening the airflow by using flow laminarizing.
- Slowing the response of the sensor by using a simple RC time constant on the output of the sensor. (This will slow down the sensor response time.)

The values needed depend on the amount of turbulence present in the application. A technique for laminarizing the flow includes adding the following separately-purchased laminar flow elements to the flow stream:

- Hex-shaped honeycombs
- Foam
- Screen materials
- Constrictors (frits)

Unfortunately, the greater the efficiency of the laminarizer, the greater the increase in pressure drop in order to establish a given flow rate. Plastic honeycomb material probably gives the most improvement for the least pressure drop.

Ensure sharp radii are avoided in any test fixture.

## ELECTRICAL CONNECTION

The AWM700 Series accepts a latch detent connector, such as AMP 103956-3. Information on latch detent connectors is available from the AMP Product Information Center, 1-800-522-6752 or the AMP Customer Hotline, 11-800-722-1111.

Table 4. Related AMP Literature

Document Number	Description
82160	MTE Interconnection System (AMP MODU) Catalog
108-25034	Product specification (technical performance information)
114-25026	Application specification (describes product, proper assembly, full tooling information)
IS6919	Instruction sheet for assembly procedure

Table 5. Order Guide

Catalog Listing	Description
AWM720P1	AWM700 series compensated/amplified airflow sensor, +200 SLPM flow range, P1 package style
AWM730B5	AWM700 series compensated/amplified airflow sensor, ±300 SLPM flow range, B5 package style