

# 1. SPECIFICATION

AX-1003-P5

ITEM		UNITS	SPECIFICATIONS	CONDITIONS
01	Rated Voltage	V	3	
02	Operating Voltage	V	2 ~ 5	
03	Consumption Current	mA (Max)	30	Rated Voltage
04	Resonant Frequency	Hz	3100± 300	Rated Voltage
05	Response times	ms	≥ 100	
06	Sound pressure level	dB(A) Min.	80	Distance at 10cm Rated Voltage / Resonant Frequency

REV NO.

REVISION NOTE

APPROVAL

DATE

PRINT

AX-1003-P5



AX-1003-P5



(+)

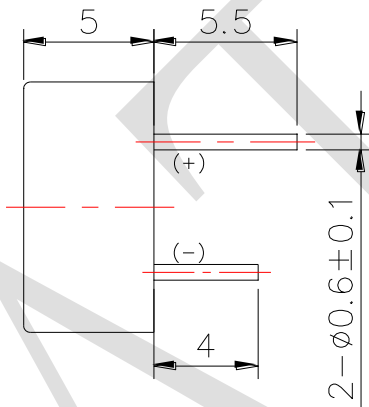
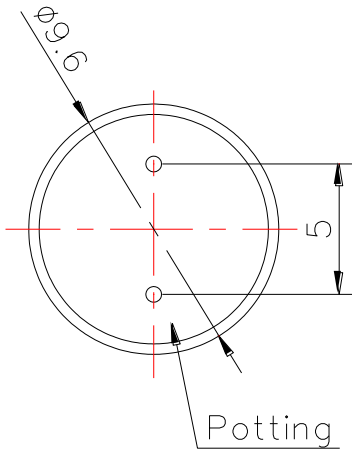

SOUND PORT  $\phi 1.5$

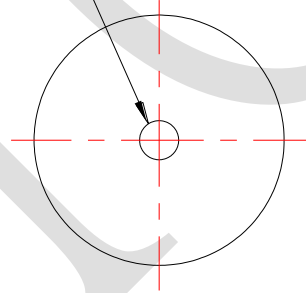

RoHS

TITLE: ELECTRO MAGNETIC BUZZER		DRAWN: <b>Moose</b>	2017/02/17	SCALE: 4:1	SHEET: 1 of 1
PART NO. AX-1003-P5		DESIGNED: R&D OF AAT		UNITS: mm	
DWC NO. FDM-2236 FDB-096050F-03031	2	CHECKED:		TOLERANCE $\pm 0.5$	
		APPROVAL:		UNLESS OTHERWISE SPECIFIED:	
REV		MATERIAL: PPO		ONE PLACE DECIMAL $\pm$ ***	
				TWO PLACE DECIMAL $\pm$ ***	
				THREE PLACE DECIMAL $\pm$ ***	



ADVANCED ACOUSTIC TECHNOLOGY CORPORATION