

1. SPECIFICATION

AX-1201-P1-LF

ITEM		UNITS	SPECIFICATIONS	CONDITIONS
01	Rated Voltage	V	1.5	
02	Operating Voltage	V	1.2 ~ 3.0	
03	Consumption Current	mA (Max)	20	Rated Voltage
04	Sound pressure level	dB(A) (Min)	80	Distance at 10cm
05	Resonant Frequency	Hz	2400±100	

REV NO.	REVISION NOTE	APPROVAL	DATE
---------	---------------	----------	------

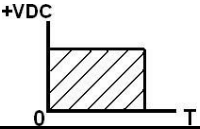
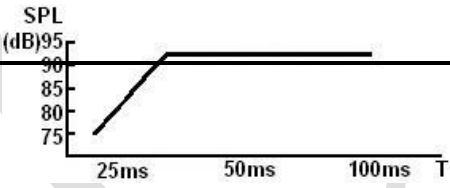
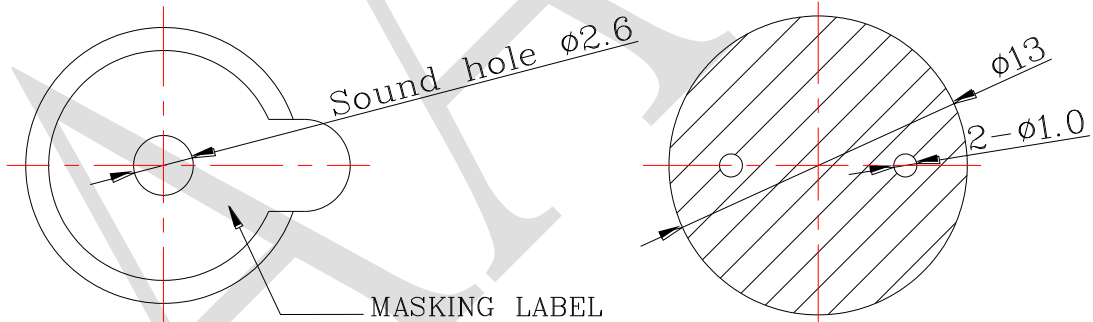
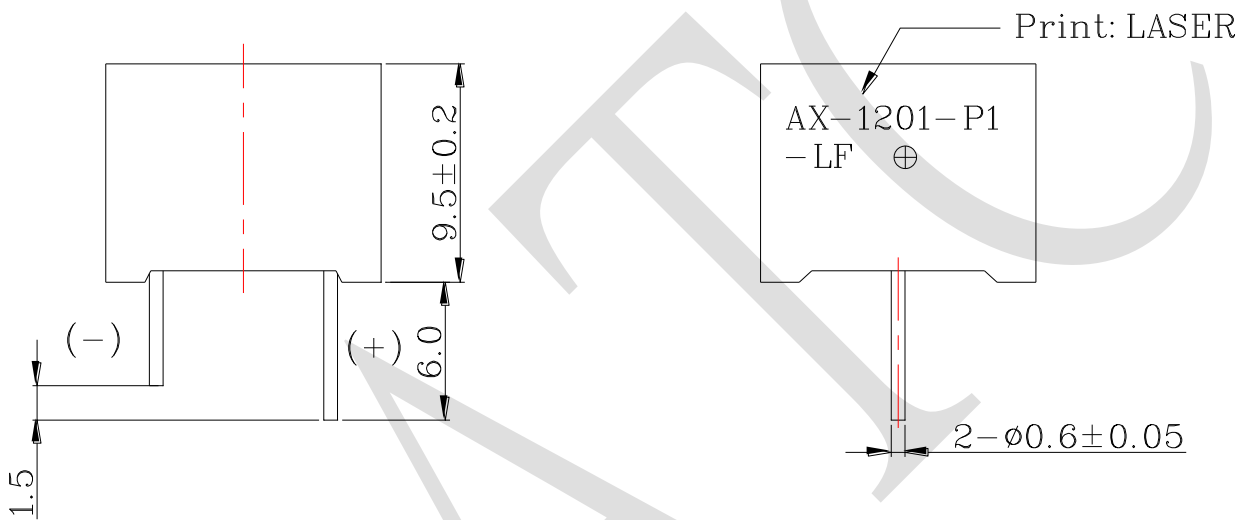
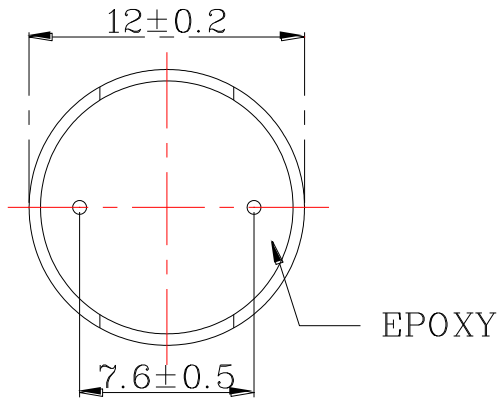

RoHS

TITLE: ELECTRO MAGNETIC BUZZER		DRAWN: Hank	2019/08/06	SCALE: 4:1	SHEET: 1 of 1
PART NO. AX-1201-P1-LF		DESIGNED: R&D OF AAT	UNITS: mm		
DWG NO. UGCM1201XPIC	3 REV	CHECKED:	TOLERANCE ± 0.2		
		APPROVAL:	UNLESS OTHERWISE SPECIFIED:		
		MATERIAL: PBT	ONE PLACE DECIMAL ± ***		
			TWO PLACE DECIMAL ± ***		
			THREE PLACE DECIMAL ± ***		



ADVANCED ACOUSTIC TECHNOLOGY CORPORATION