

1. SPECIFICATION

AI-1205-BH-1P

ITEM		UNITS	SPECIFICATIONS	CONDITIONS
01	Rated Voltage	V	5	
02	Operating Voltage	V	3 ~ 7	
03	Mean consumption Current	mA Max.	30	
04	Resonant Frequency	Hz	2300 ± 300	
05	Response times	ms	≥ 100	
06	Sound pressure level	dB(A)	Min. 85	

Rated Voltage, Distance at 10cm

REV NO.	REVISION NOTE	APPROVAL	DATE
---------	---------------	----------	------

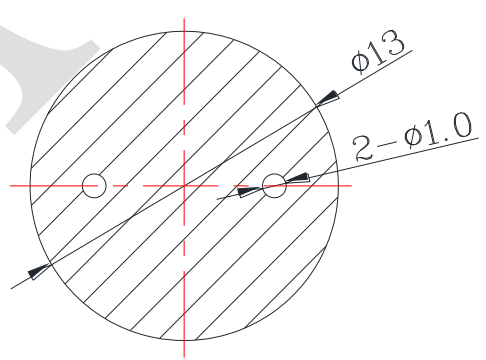
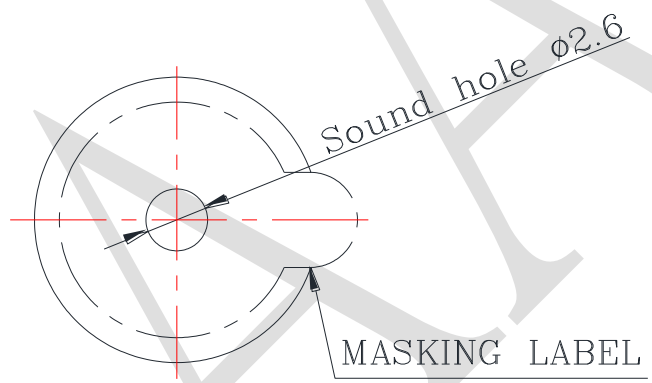
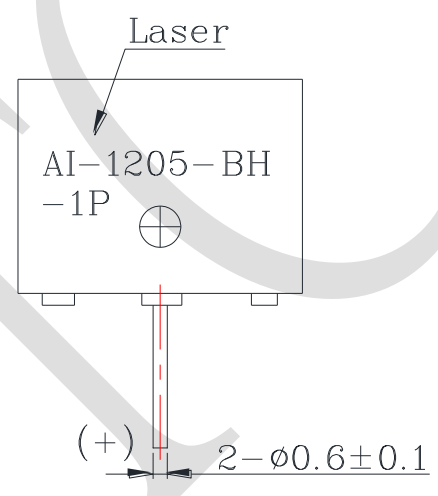
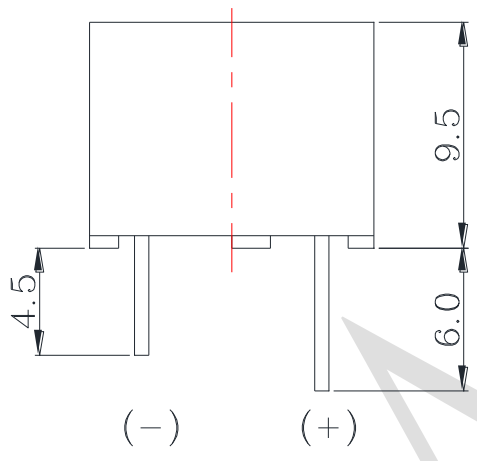
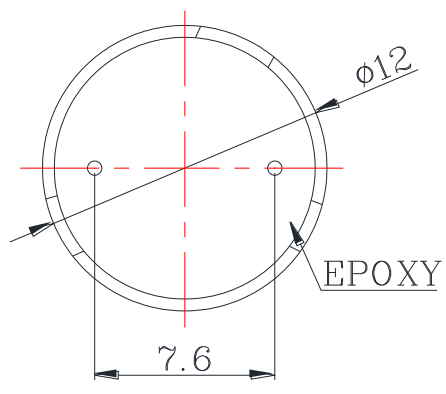

RECOMMENDED PCB LAYOUT

※禁止極性反接※
Prohibit reverse polarity

RoHS

TITLE: ELECTRO MAGNETIC BUZZER	DRAWN: Zack	2016/01/18	SCALE: 4:1	SHEET: 1 of 1
PART NO. AI-1205-BH-1P	DESIGNED: R&D OF AAT		UNITS: mm	
DWG NO. UGCM1205XPIC	CHECKED:		TOLERANCE ± 0.5	
	APPROVAL:		UNLESS OTHERWISE SPECIFIED:	
	MATERIAL: PBT		ONE PLACE DECIMAL ± ***	
			TWO PLACE DECIMAL ± ***	
			THREE PLACE DECIMAL ± ***	



ADVANCED ACOUSTIC TECHNOLOGY CORPORATION