

LOW DROPOUT LINEAR REGULATOR**AZ1117B****General Description**

The AZ1117B is a low dropout three-terminal regulator.

The AZ1117B has been optimized for low voltage where transient response and minimum input voltage are critical. It provides current limit and thermal shutdown. Its circuit includes a trimmed bandgap reference to assure output voltage accuracy to be within $\pm 1\%$. On-chip thermal shutdown provides protection against a combination of high current and ambient temperature that would create excessive junction temperature.

The AZ1117B is available in 1.2V, 1.5V, 1.8V, 2.5V, 3.3V, 5.0V fixed output voltage versions and ADJ output voltage version. The fixed versions integrate the adjust resistors. It is also available in an adjustable version which can set the output voltage with two external resistors.

The AZ1117B is available in the industry-standard TO-252-2 (1), TO-252-2 (2), TO-252-2 (3), SOT-223 and SOT-89 power packages.

Features

- Current Limit: 1.0A (Typ.)
- Output Noise from 10Hz to 10KHz: 0.003% of V_{OUT}
- PSRR at $I_{OUT}=300mA$ and $f=120Hz$: 70dB
- Output Voltage Accuracy: $\pm 1\%$
- On-chip Thermal Shutdown
- Maximum Quiescent Current: $I_{QMAX}=6mA$
- Operation Junction Temperature: -20 to 125°C

Applications

- USB Device
- Add-on Card
- DVD Player
- PC Motherboard

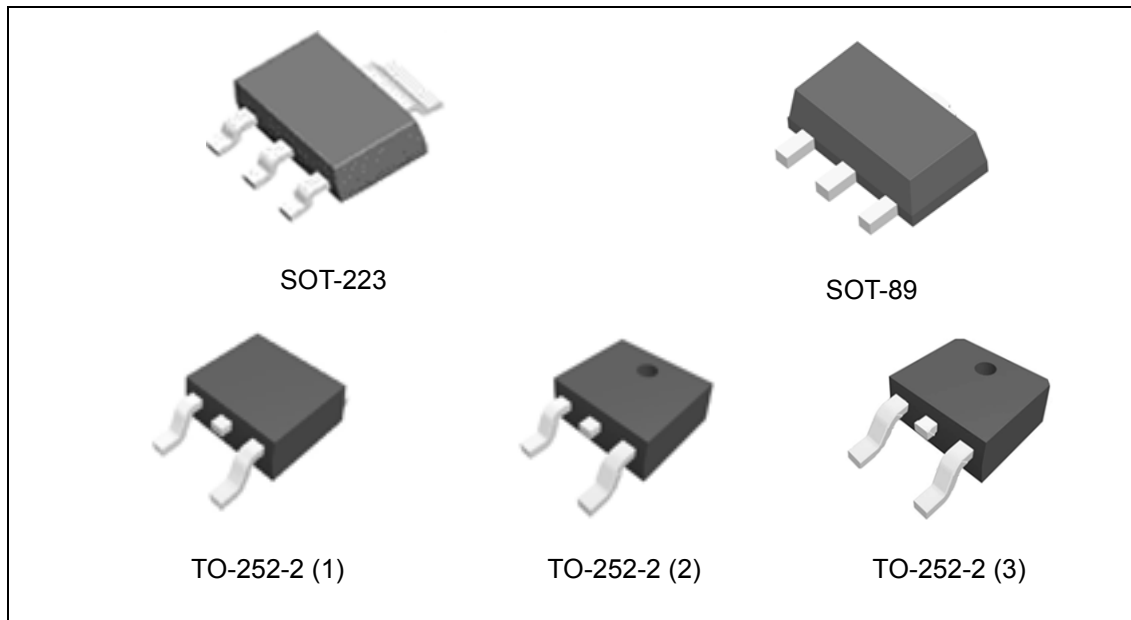

Figure 1. Package Type of AZ1117B

LOW DROPOUT LINEAR REGULATOR**AZ1117B****Pin Configuration**

Figure 2. Pin Configuration of AZ1117B (Top View)

LOW DROPOUT LINEAR REGULATOR

AZ1117B

Functional Block Diagram

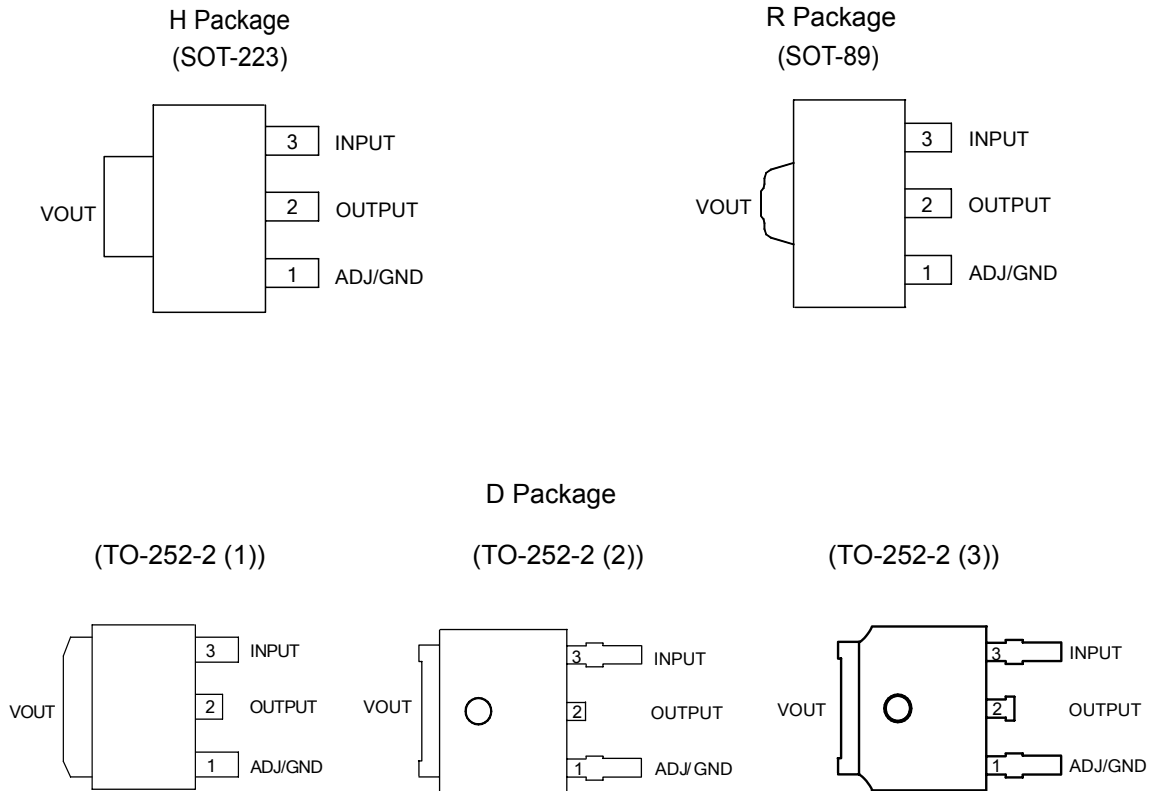
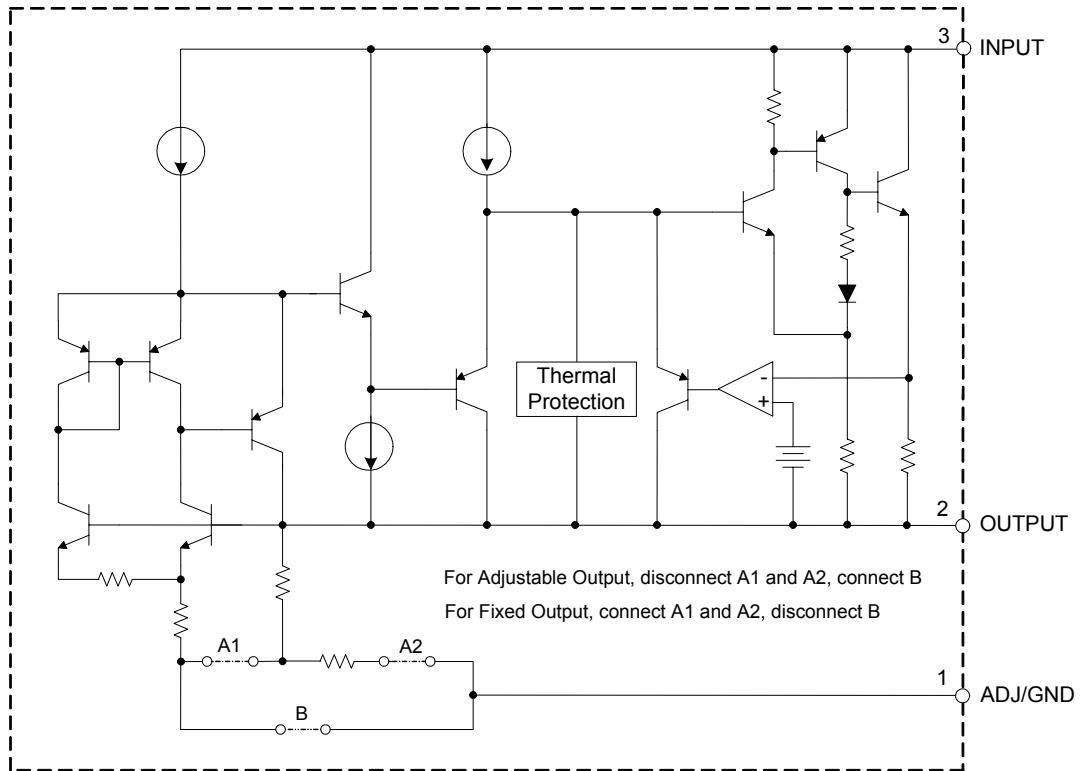

Figure 3. Functional Block Diagram of AZ1117B



LOW DROPOUT LINEAR REGULATOR

AZ1117B

Ordering Information

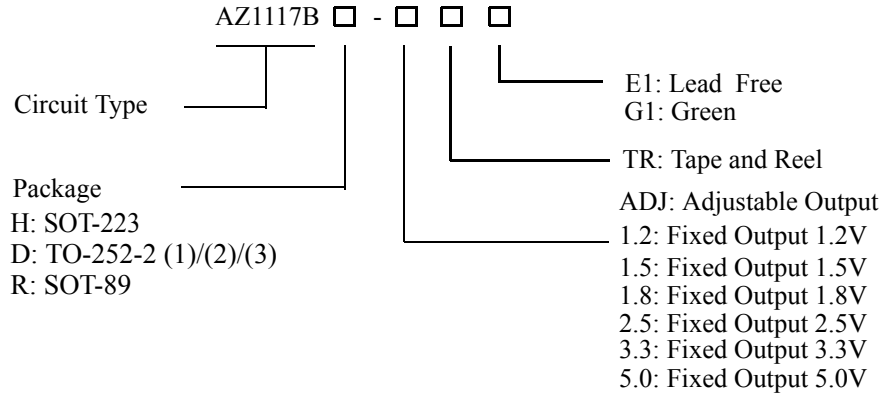

Package	Temperature Range	Part Number		Marking ID		Packing Type
		Lead Free	Green	Lead Free	Green	
SOT-223	-20 to 125°C	AZ1117BH-ADJTRE1	AZ1117H-ADJTRG1	EH17K	GH17K	Tape & Reel
		AZ1117BH-1.2TRE1	AZ1117H-1.2TRG1	EH17P	GH17P	Tape & Reel
		AZ1117BH-1.5TRE1	AZ1117H-1.5TRG1	EH17Q	GH17Q	Tape & Reel
		AZ1117BH-1.8TRE1	AZ1117H-1.8TRG1	EH17L	GH17L	Tape & Reel
		AZ1117BH-2.5TRE1	AZ1117H-2.5TRG1	EH17N	GH17N	Tape & Reel
		AZ1117BH-3.3TRE1	AZ1117H-3.3TRG1	EH17M	GH17M	Tape & Reel
		AZ1117BH-5.0TRE1	AZ1117H-5.0TRG1	EH17R	GH17R	Tape & Reel
TO-252-2 (1)/ TO-252-2 (2)/ TO-252-2 (3)	-20 to 125°C	AZ1117BD-ADJE1	AZ1117D-ADJG1	AZ1117BD-ADJE1	AZ1117D-ADJG1	Tube
		AZ1117BD-ADJTRE1	AZ1117D-ADJTRG1	AZ1117BD-ADJE1	AZ1117D-ADJG1	Tape & Reel
		AZ1117BD-1.2E1	AZ1117D-1.2G1	AZ1117BD-1.2E1	AZ1117D-1.2G1	Tube
		AZ1117BD-1.2TRE1	AZ1117D-1.2TRG1	AZ1117BD-1.2E1	AZ1117D-1.2G1	Tape & Reel
		AZ1117BD-1.5E1	AZ1117D-1.5G1	AZ1117BD-1.5E1	AZ1117D-1.5G1	Tube
		AZ1117BD-1.5TRE1	AZ1117D-1.5TRG1	AZ1117BD-1.5E1	AZ1117D-1.5G1	Tape & Reel
		AZ1117BD-1.8E1	AZ1117D-1.8G1	AZ1117BD-1.8E1	AZ1117D-1.8G1	Tube
		AZ1117BD-1.8TRE1	AZ1117D-1.8TRG1	AZ1117BD-1.8E1	AZ1117D-1.8G1	Tape & Reel
		AZ1117BD-2.5E1	AZ1117D-2.5G1	AZ1117BD-2.5E1	AZ1117D-2.5G1	Tube
		AZ1117BD-2.5TRE1	AZ1117D-2.5TRG1	AZ1117BD-2.5E1	AZ1117D-2.5G1	Tape & Reel
		AZ1117BD-3.3E1	AZ1117D-3.3G1	AZ1117BD-3.3E1	AZ1117D-3.3G1	Tube
		AZ1117BD-3.3TRE1	AZ1117D-3.3TRG1	AZ1117BD-3.3E1	AZ1117D-3.3G1	Tape & Reel
		AZ1117BD-5.0E1	AZ1117D-5.0G1	AZ1117BD-5.0E1	AZ1117D-5.0G1	Tube
		AZ1117BD-5.0TRE1	AZ1117D-5.0TRG1	AZ1117BD-5.0E1	AZ1117D-5.0G1	Tape & Reel

**LOW DROPOUT LINEAR REGULATOR****AZ1117B****Ordering Information (Continued)**

Package	Temperature Range	Part Number		Marking ID		Packing Type
		Lead Free	Green	Lead Free	Green	
SOT-89	-20 to 125°C	AZ1117BR-ADJTRE1	AZ1117R-ADJTRG1	E31F	G31F	Tape & Reel
		AZ1117BR-1.2TRE1	AZ1117R-1.2TRG1	E31G	G31G	Tape & Reel
		AZ1117BR-1.5TRE1	AZ1117R-1.5TRG1	E31H	G31H	Tape & Reel
		AZ1117BR-1.8TRE1	AZ1117R-1.8TRG1	E31J	G31J	Tape & Reel
		AZ1117BR-2.5TRE1	AZ1117R-2.5TRG1	E31K	G31K	Tape & Reel
		AZ1117BR-3.3TRE1	AZ1117R-3.3TRG1	E31L	G31L	Tape & Reel
		AZ1117BR-5.0TRE1	AZ1117R-5.0TRG1	E31M	G31M	Tape & Reel

BCD Semiconductor's Pb-free products, as designated with "E1" suffix in the part number, are RoHS compliant. Products with "G1" suffix are available in green packages.

**LOW DROPOUT LINEAR REGULATOR****AZ1117B****Absolute Maximum Ratings (Note 1)**

Parameter	Symbol	Value		Unit
Input Voltage	V_{IN}	18		V
Operating Junction Temperature Range	T_J	150		°C
Storage Temperature Range	T_{STG}	-65 to 150		°C
Thermal Resistance (No Heatsink)	θ_{JA}	SOT-223	150	°C/W
		TO-252-2(1)/TO-252-2(2) TO-252-2(3)	128	
		SOT-89	210	
Lead Temperature (Soldering, 10sec)	T_{LEAD}	260		°C

Note 1: Stresses greater than those listed under "Absolute Maximum Ratings" may cause permanent damage to the device. These are stress ratings only, and functional operation of the device at these or any other conditions beyond those indicated under "Recommended Operating Conditions" is not implied. Exposure to "Absolute Maximum Ratings" for extended periods may affect device reliability.

Recommended Operating Conditions

Parameter	Symbol	Min	Max	Unit
Input Voltage	V_{IN}		15	V
Operating Junction Temperature Range	T_J	-20	125	°C



LOW DROPOUT LINEAR REGULATOR

AZ1117B

Electrical Characteristics

AZ1117B-ADJ Electrical Characteristics

Operating Conditions: $V_{IN}=V_{OUT}+2V$, $I_{OUT}=10mA$, $T_J=25^{\circ}C$, unless otherwise specified. ($P \leq$ maximum power dissipation).

Limits appearing in **Boldface** type apply over the entire junction temperature range for operation, $-20^{\circ}C$ to $125^{\circ}C$.

Parameter	Symbol	Conditions	Min	Typ	Max	Uni	
Reference Voltage	V_{REF}		1.238	1.250	1.262	V	
		$1.5V \leq V_{IN} - V_{OUT} \leq 10V$	1.225	1.250	1.270		
Line Regulation	V_{RLINE}	$1.5V \leq V_{IN} - V_{OUT} \leq 10V$		0.001	0.1	%	
					0.2		
Load Regulation	V_{RLOAD}			0.4	1.0	%	
Dropout Voltage	V_{DROP}	$\Delta V_{REF}=1\%$, $I_{OUT}=0.8A$	SOT-223		1.2	1.3	V
			TO-252-2(1)/(2)/(3)		1.4		
			SOT-89		1.2		
Current Limit	I_{LIMIT}		0.85	1	1.15	A	
Adjust Pin Current				60	120	μA	
Adjust Pin Current Change		$1.5V \leq (V_{IN} - V_{OUT}) \leq 10V$		0.2	5	μA	
Minimum Load Current		$1.5V \leq (V_{IN} - V_{OUT}) \leq 10V$		1.7	5	mA	
Ripple Rejection	PSRR	$f=120Hz$, $C_{OUT}=22\mu F$ $(V_{IN} - V_{OUT})=3V$, $I_{OUT}=300mA$		70		dB	
Temperature Stability				0.5		%	
RMS Output Noise (% of V_{OUT})		$T_A=25^{\circ}C$, $10Hz \leq f \leq 10KHz$		0.003		%	
Thermal Shutdown		Junction Temperature		160		$^{\circ}C$	
Thermal Shutdown Hysteresis				16		$^{\circ}C$	
Thermal Resistance	θ_{JC}	SOT-223		33		$^{\circ}C/W$	
		TO-252-2 (1)/TO-252-2 (2)/TO-252-2 (3)		22			
		SOT-89		39			



LOW DROPOUT LINEAR REGULATOR

AZ1117B

Electrical Characteristics (Continued)

AZ1117B-1.2 Electrical Characteristics

Operating Conditions: $V_{IN} \leq 10V$, $I_{OUT} = 10mA$, $T_J = 25^\circ C$, unless otherwise specified. ($P \leq$ maximum power dissipation). Limits appearing in **Boldface** type apply over the entire junction temperature range for operation, $-20^\circ C$ to $125^\circ C$.

Parameter	Symbol	Conditions	Min	Typ	Max	Unit	
Output Voltage	V_{OUT}		1.176	1.2	1.224	V	
		$3.2V \leq V_{IN} \leq 10V$	1.152	1.2	1.228		
Line Regulation	V_{RLINE}	$1.5V \leq V_{IN} - V_{OUT} \leq 10V$		0.5	6	mV	
					10		
Load Regulation	V_{RLOAD}			2	15	mV	
Dropout Voltage	V_{DROP}	$\Delta V_{OUT} = 1\%$, $I_{OUT} = 0.8A$	SOT-223		1.2	1.3	V
			TO-252-2(1)/(2)/(3)		1.4		
			SOT-89		1.2		
Current Limit	I_{LIMIT}		0.85	1	1.15	A	
Quiescent Current	I_Q	$I_{OUT} = 0$		4	6	mA	
Ripple Rejection	PSRR	$f = 120Hz$, $C_{OUT} = 22\mu F$ $(V_{IN} - V_{OUT}) = 3V$, $I_{OUT} = 300mA$		70		dB	
Temperature Stability				0.5		%	
RMS Output Noise (% of V_{OUT})		$T_A = 25^\circ C$, $10Hz \leq f \leq 10KHz$		0.003		%	
Thermal Shutdown		Junction Temperature		160		$^\circ C$	
Thermal Shutdown Hysteresis				16		$^\circ C$	
Thermal Resistance	θ_{JC}	SOT-223		33		$^\circ C/W$	
		TO-252-2 (1)/TO-252-2 (2)/TO-252-2 (3)		22			
		SOT-89		39			



LOW DROPOUT LINEAR REGULATOR

AZ1117B

Electrical Characteristics (Continued)

AZ1117B-1.5 Electrical Characteristics

Operating Conditions: $V_{IN} \leq 10V$, $I_{OUT} = 10mA$, $T_J = 25^\circ C$, unless otherwise specified. ($P \leq$ maximum power dissipation). Limits appearing in **Boldface** type apply over the entire junction temperature range for operation, $-20^\circ C$ to $125^\circ C$.

Parameter	Symbol	Conditions	Min	Typ	Max	Unit	
Output Voltage	V_{OUT}		1.485	1.5	1.515	V	
		$3.5V \leq V_{IN} \leq 10V$	1.470	1.5	1.530		
Line Regulation	V_{RLINE}	$1.5V \leq V_{IN} - V_{OUT} \leq 10V$		0.5	6	mV	
					10		
Load Regulation	V_{RLOAD}			2	15	mV	
Dropout Voltage	V_{DROP}	$\Delta V_{OUT} = 1\%$, $I_{OUT} = 0.8A$	SOT-223		1.2	1.3	V
			TO-252-2(1)/(2)/(3)		1.4		
			SOT-89		1.2		
Current Limit	I_{LIMIT}		0.85	1	1.15	A	
Quiescent Current	I_Q	$I_{OUT} = 0$		4	6	mA	
Ripple Rejection	PSRR	$f = 120Hz$, $C_{OUT} = 22\mu F$ $(V_{IN} - V_{OUT}) = 3V$, $I_{OUT} = 300mA$		70		dB	
Temperature Stability				0.5		%	
RMS Output Noise (% of V_{OUT})		$T_A = 25^\circ C$, $10Hz \leq f \leq 10KHz$		0.003		%	
Thermal Shutdown		Junction Temperature		160		$^\circ C$	
Thermal Shutdown Hysteresis				16		$^\circ C$	
Thermal Resistance	θ_{JC}	SOT-223		33		$^\circ C/W$	
		TO-252-2 (1)/TO-252-2 (2)/TO-252-2 (3)		22			
		SOT-89		39			



LOW DROPOUT LINEAR REGULATOR

AZ1117B

Electrical Characteristics (Continued)

AZ1117B-1.8 Electrical Characteristics

Operating Conditions: $V_{IN} \leq 10V$, $I_{OUT} = 10mA$, $T_J = 25^\circ C$, unless otherwise specified. ($P \leq$ maximum power dissipation). Limits appearing in **Boldface** type apply over the entire junction temperature range for operation, $-20^\circ C$ to $125^\circ C$.

Parameter	Symbol	Conditions	Min	Typ	Max	Unit	
Output Voltage	V_{OUT}		1.782	1.8	1.818	V	
		$3.8V \leq V_{IN} \leq 10V$	1.764	1.8	1.836		
Line Regulation	V_{RLINE}	$1.5V \leq V_{IN} - V_{OUT} \leq 10V$		0.5	6	mV	
					10		
Load Regulation	V_{RLOAD}			2	15	mV	
Dropout Voltage	V_{DROP}	$\Delta V_{OUT} = 1\%$, $I_{OUT} = 0.8A$	SOT-223		1.2	1.3	V
			TO-252-2(1)/(2)/(3)		1.4		
			SOT-89		1.2		
Current Limit	I_{LIMIT}		0.85	1	1.15	A	
Quiescent Current	I_Q	$I_{OUT} = 0$		4	6	mA	
Ripple Rejection	PSRR	$f = 120Hz$, $C_{OUT} = 22\mu F$ $(V_{IN} - V_{OUT}) = 3V$, $I_{OUT} = 300mA$		70		dB	
Temperature Stability				0.5		%	
RMS Output Noise (% of V_{OUT})		$T_A = 25^\circ C$, $10Hz \leq f \leq 10KHz$		0.003		%	
Thermal Shutdown		Junction Temperature		160		$^\circ C$	
Thermal Shutdown Hysteresis				16		$^\circ C$	
Thermal Resistance	θ_{JC}	SOT-223		33		$^\circ C/W$	
		TO-252-2 (1)/TO-252-2 (2)/TO-252-2 (3)		22			
		SOT-89		39			



LOW DROPOUT LINEAR REGULATOR

AZ1117B

Electrical Characteristics (Continued)

AZ1117B-2.5 Electrical Characteristics

Operating Conditions: $V_{IN} \leq 10V$, $I_{OUT} = 10mA$, $T_J = 25^\circ C$, unless otherwise specified. ($P \leq$ maximum power dissipation). Limits appearing in **Boldface** type apply over the entire junction temperature range for operation, $-20^\circ C$ to $125^\circ C$.

Parameter	Symbol	Conditions	Min	Typ	Max	Unit	
Output Voltage	V_{OUT}		2.475	2.5	2.525	V	
		$4.5V \leq V_{IN} \leq 10V$	2.455	2.5	2.545		
Line Regulation	V_{RLINE}	$1.5V \leq V_{IN} - V_{OUT} \leq 10V$		0.5	6	mV	
					10		
Load Regulation	V_{RLOAD}			2	15	mV	
Dropout Voltage	V_{DROP}	$\Delta V_{OUT} = 1\%$, $I_{OUT} = 0.8A$	SOT-223		1.2	1.3	V
			TO-252-2(1)/(2)/(3)		1.4		
			SOT-89		1.2		
Current Limit	I_{LIMIT}		0.85	1	1.15	A	
Quiescent Current	I_Q	$I_{OUT} = 0$		4	6	mA	
Ripple Rejection	PSRR	$f = 120Hz$, $C_{OUT} = 22\mu F$ $(V_{IN} - V_{OUT}) = 3V$, $I_{OUT} = 300mA$		70		dB	
Temperature Stability				0.5		%	
RMS Output Noise (% of V_{OUT})		$T_A = 25^\circ C$, $10Hz \leq f \leq 10KHz$		0.003		%	
Thermal Shutdown		Junction Temperature		160		$^\circ C$	
Thermal Shutdown Hysteresis				16		$^\circ C$	
Thermal Resistance	θ_{JC}	SOT-223		33		$^\circ C/W$	
		TO-252-2 (1)/TO-252-2 (2)/TO-252-2 (3)		22			
		SOT-89		39			



LOW DROPOUT LINEAR REGULATOR

AZ1117B

Electrical Characteristics (Continued)

AZ1117B-3.3 Electrical Characteristics

Operating Conditions: $V_{IN} \leq 10V$, $I_{OUT} = 10mA$, $T_J = 25^\circ C$, unless otherwise specified. ($P \leq$ maximum power dissipation). Limits appearing in **Boldface** type apply over the entire junction temperature range for operation, $-20^\circ C$ to $125^\circ C$.

Parameter	Symbol	Conditions	Min	Typ	Max	Unit	
Output Voltage	V_{OUT}		3.267	3.3	3.333	V	
		$5.3V \leq V_{IN} \leq 10V$	3.235	3.3	3.365		
Line Regulation	V_{RLINE}	$1.5V \leq V_{IN} - V_{OUT} \leq 10V$		0.5	6	mV	
					10		
Load Regulation	V_{RLOAD}			2	15	mV	
Dropout Voltage	V_{DROP}	$\Delta V_{OUT} = 1\%$, $I_{OUT} = 0.8A$	SOT-223		1.2	1.3	V
			TO-252-2(1)/(2)/(3)		1.4		
			SOT-89		1.2		
Current Limit	I_{LIMIT}		0.85	1	1.15	A	
Quiescent Current	I_Q	$I_{OUT} = 0$		4	6	mA	
Ripple Rejection	PSRR	$f = 120Hz$, $C_{OUT} = 22\mu F$ $(V_{IN} - V_{OUT}) = 3V$, $I_{OUT} = 300mA$		70		dB	
Temperature Stability				0.5		%	
RMS Output Noise (% of V_{OUT})		$T_A = 25^\circ C$, $10Hz \leq f \leq 10KHz$		0.003		%	
Thermal Shutdown		Junction Temperature		160		$^\circ C$	
Thermal Shutdown Hysteresis				16		$^\circ C$	
Thermal Resistance	θ_{JC}	SOT-223		33		$^\circ C/W$	
		TO-252-2 (1)/TO-252-2 (2)/TO-252-2 (3)		22			
		SOT-89		39			



LOW DROPOUT LINEAR REGULATOR

AZ1117B

Electrical Characteristics (Continued)

AZ1117B-5.0 Electrical Characteristics

Operating Conditions: $V_{IN} \leq 10V$, $I_{OUT} = 10mA$, $T_J = 25^\circ C$, unless otherwise specified. ($P \leq$ maximum power dissipation). Limits appearing in **Boldface** type apply over the entire junction temperature range for operation, $-20^\circ C$ to $125^\circ C$.

Parameter	Symbol	Conditions	Min	Typ	Max	Unit	
Output Voltage	V_{OUT}		4.950	5.0	5.050	V	
		$6.5V \leq V_{IN} \leq 10V$	4.900	5.0	5.100		
Line Regulation	V_{RLINE}	$1.5V \leq V_{IN} - V_{OUT} \leq 10V$		0.5	6	mV	
					10		
Load Regulation	V_{RLOAD}			2	15	mV	
Dropout Voltage	V_{DROP}	$\Delta V_{OUT} = 1\%$, $I_{OUT} = 0.8A$	SOT-223		1.2	1.3	V
			TO-252-2(1)/(2)/(3)		1.4		
			SOT-89		1.2		
Current Limit	I_{LIMIT}		0.85	1	1.15	A	
Quiescent Current	I_Q	$I_{OUT} = 0$		4	6	mA	
Ripple Rejection	PSRR	$f = 120Hz$, $C_{OUT} = 22\mu F$ $(V_{IN} - V_{OUT}) = 3V$, $I_{OUT} = 300mA$		70		dB	
Temperature Stability				0.5		%	
RMS Output Noise (% of V_{OUT})		$T_A = 25^\circ C$, $10Hz \leq f \leq 10KHz$		0.003		%	
Thermal Shutdown		Junction Temperature		160		$^\circ C$	
Thermal Shutdown Hysteresis				16		$^\circ C$	
Thermal Resistance	θ_{JC}	SOT-223		33		$^\circ C/W$	
		TO-252-2 (1)/TO-252-2 (2)/TO-252-2 (3)		22			
		SOT-89		39			



LOW DROPOUT LINEAR REGULATOR

AZ1117B

Typical Performance Characteristics

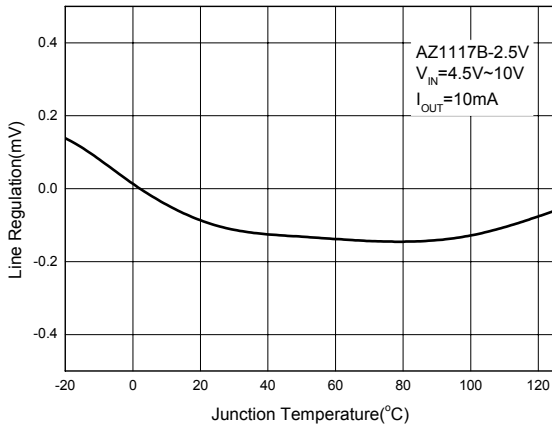

Figure 4. Line Regulation vs. Junction Temperature

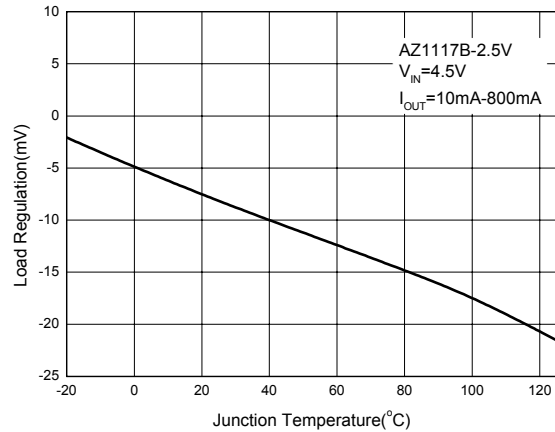

Figure 5. Load Regulation vs. Junction Temperature

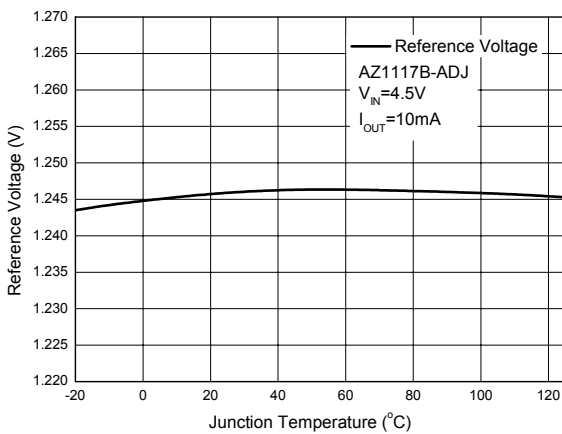

Figure 6. Reference Voltage vs. Junction Temperature

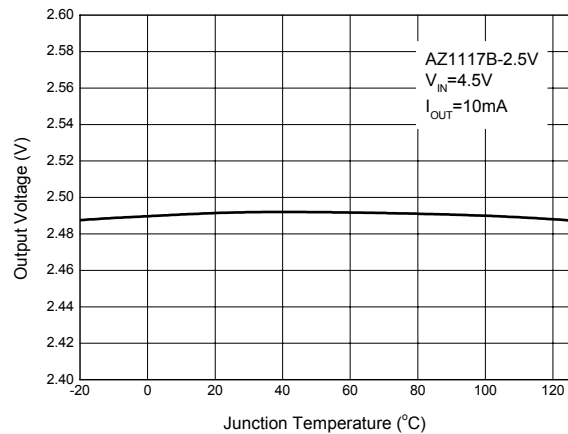

Figure 7. Output Voltage vs. Junction Temperature



LOW DROPOUT LINEAR REGULATOR

AZ1117B

Typical Performance Characteristics (Continued)

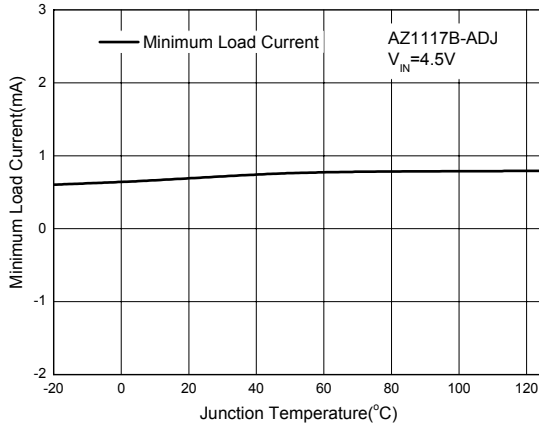

Figure 8. Minimum Load Current vs. Junction Temperature

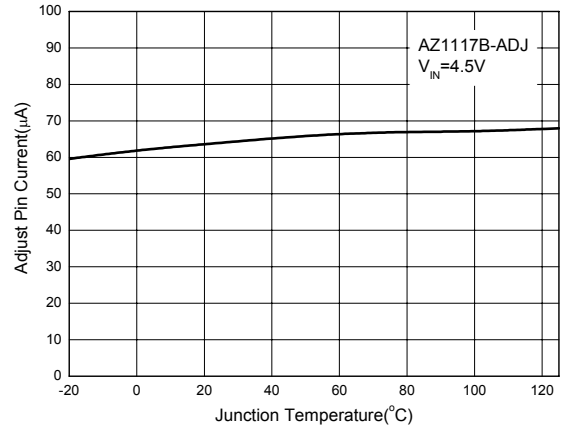

Figure 9. Adjust Pin Current vs. Junction Temperature

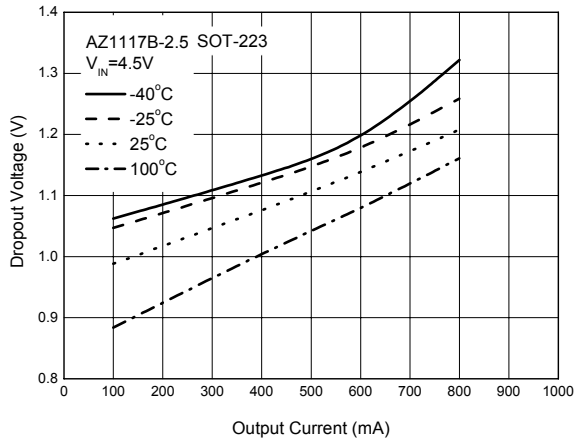

Figure 10. Dropout Voltage vs. Output Current

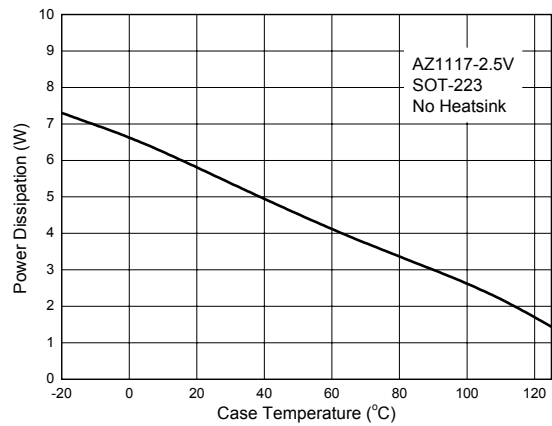

Figure 11. Power Dissipation vs. Case Temperature



LOW DROPOUT LINEAR REGULATOR

AZ1117B

Typical Performance Characteristics (Continued)

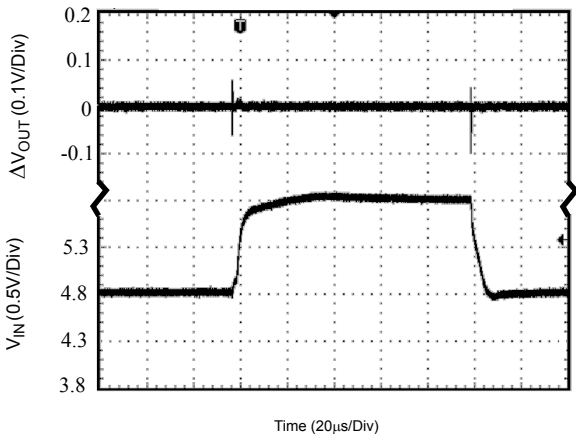

Figure 12. Line Transient Response

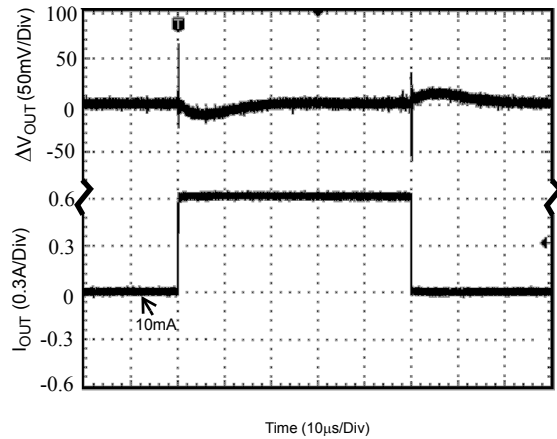

Figure 13. Load Transient Response

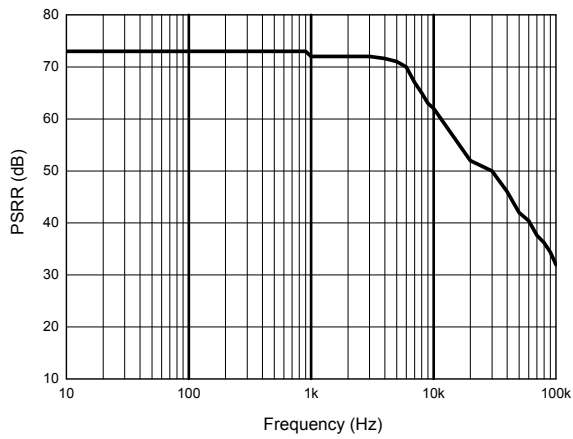

Figure 14. PSRR vs. Frequency

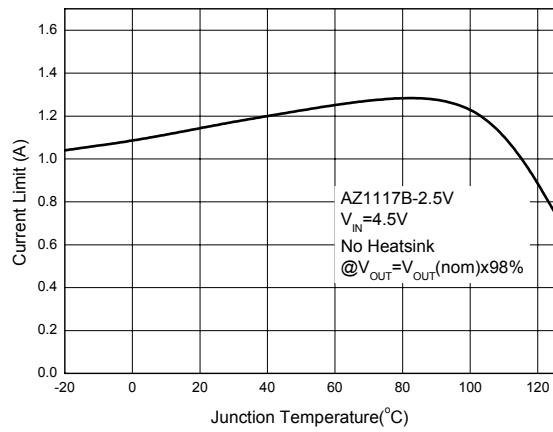

Figure 15. Current Limit vs. Junction Temperature



LOW DROPOUT LINEAR REGULATOR **AZ1117B**

Typical Performance Characteristics (Continued)

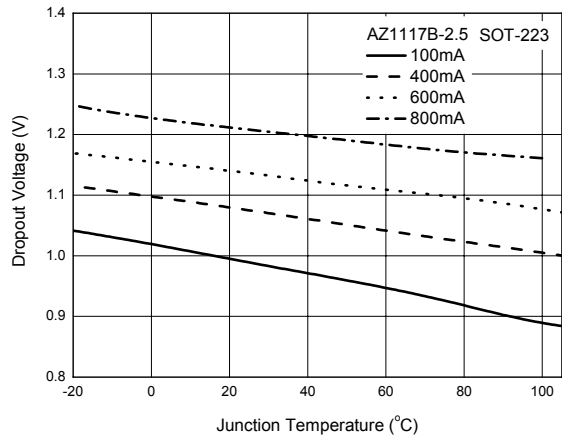

Figure 16. Dropout Voltage vs. Junction Temperature

Typical Applications

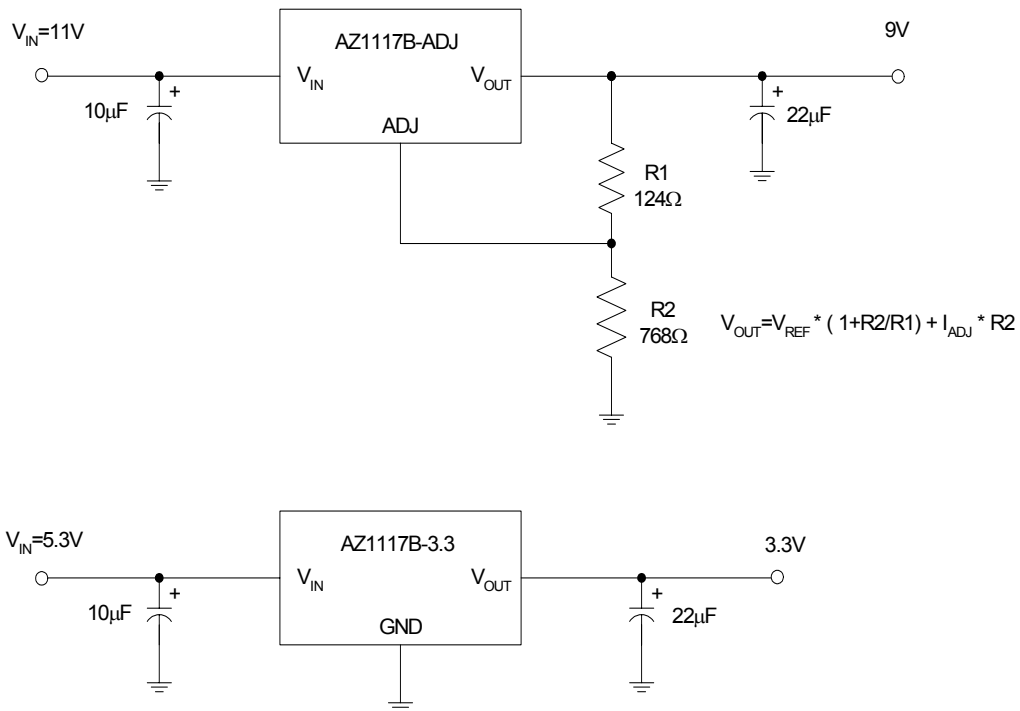

Figure 17. Typical Applications of AZ1117B



LOW DROPOUT LINEAR REGULATOR

AZ1117B

Mechanical Dimensions

SOT-223

Unit: mm(inch)

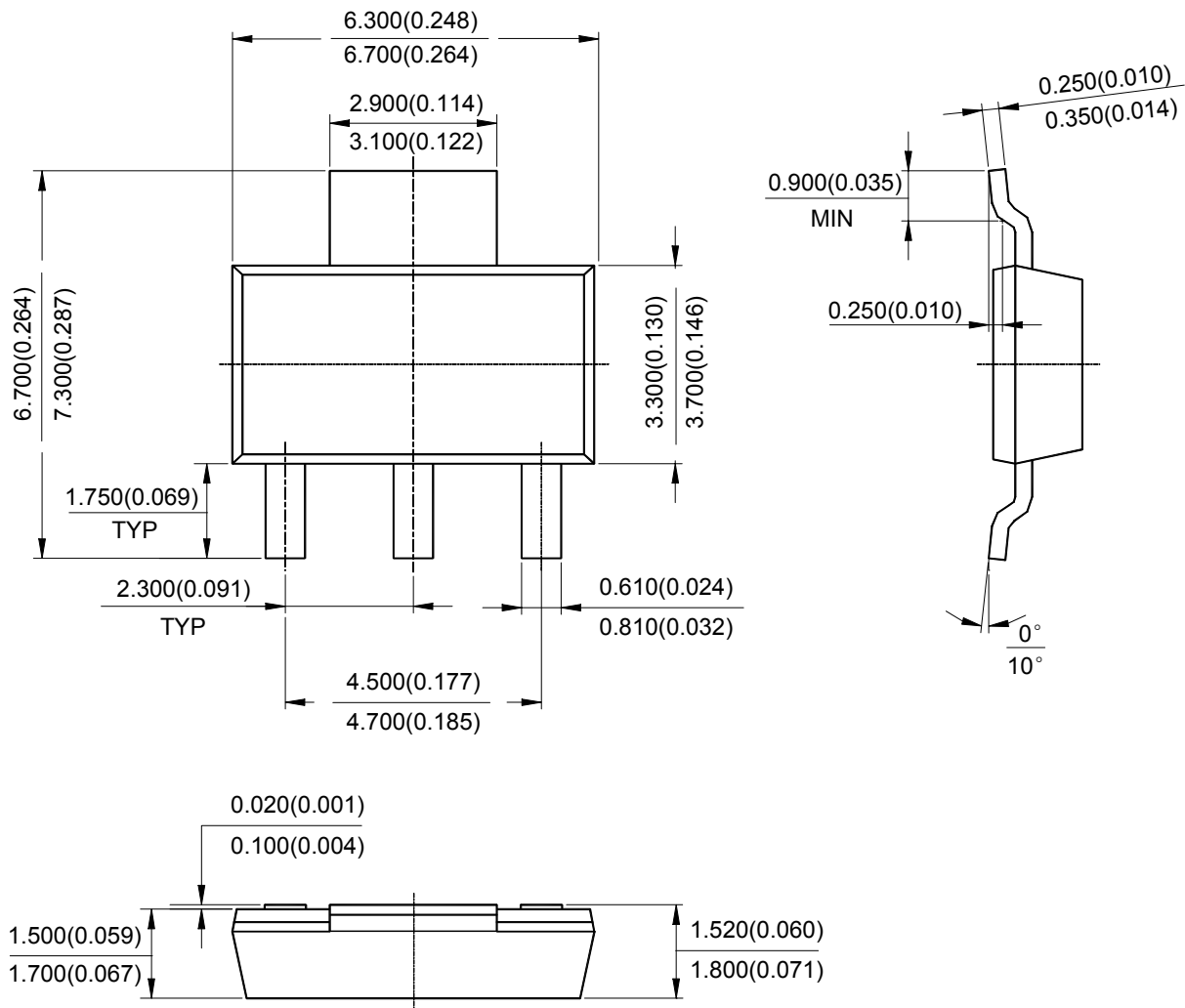



LOW DROPOUT LINEAR REGULATOR

AZ1117B

Mechanical Dimensions (Continued)

TO-252-2 (1)

Unit: mm(inch)

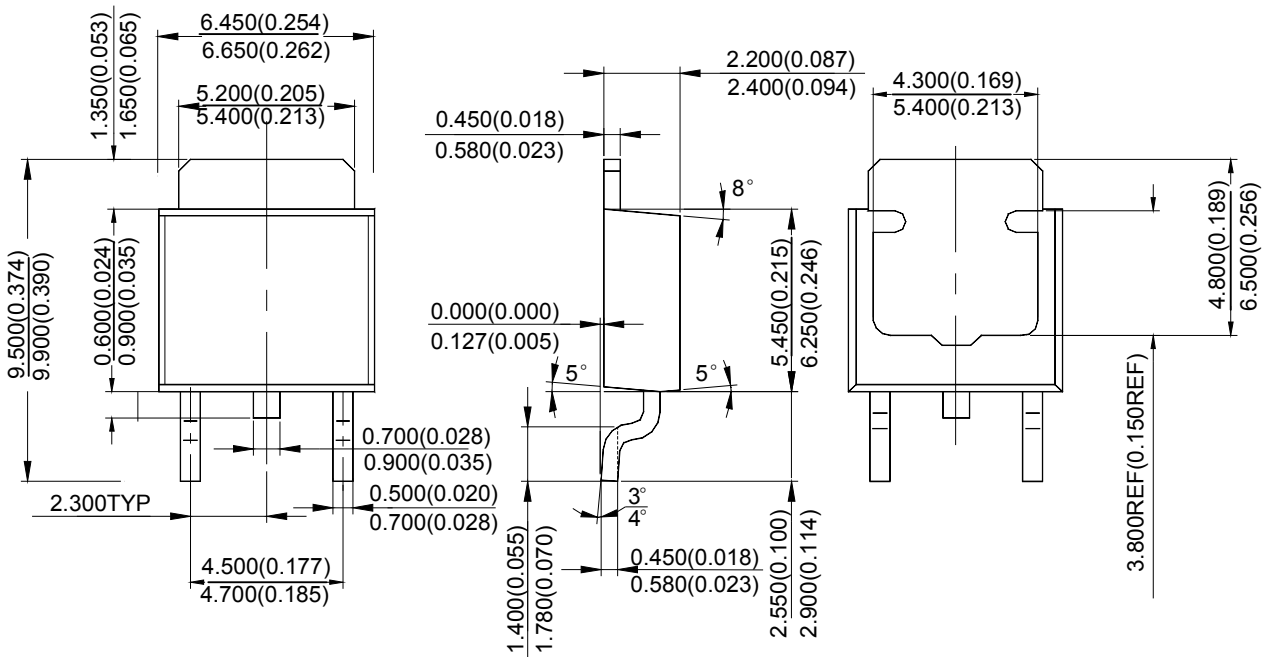



LOW DROPOUT LINEAR REGULATOR

AZ1117B

Mechanical Dimensions (Continued)

TO-252-2 (2)

Unit: mm(inch)

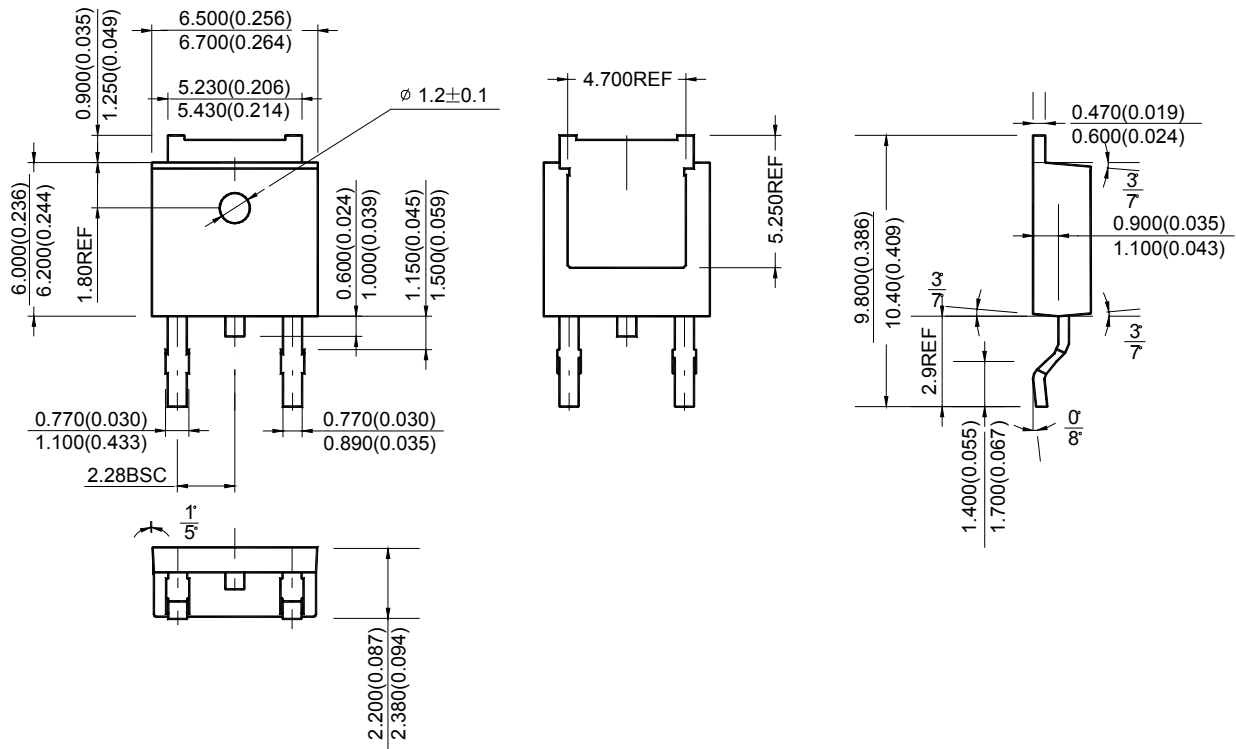



LOW DROPOUT LINEAR REGULATOR

AZ1117B

Mechanical Dimensions (Continued)

TO-252-2 (3)

Unit: mm(inch)

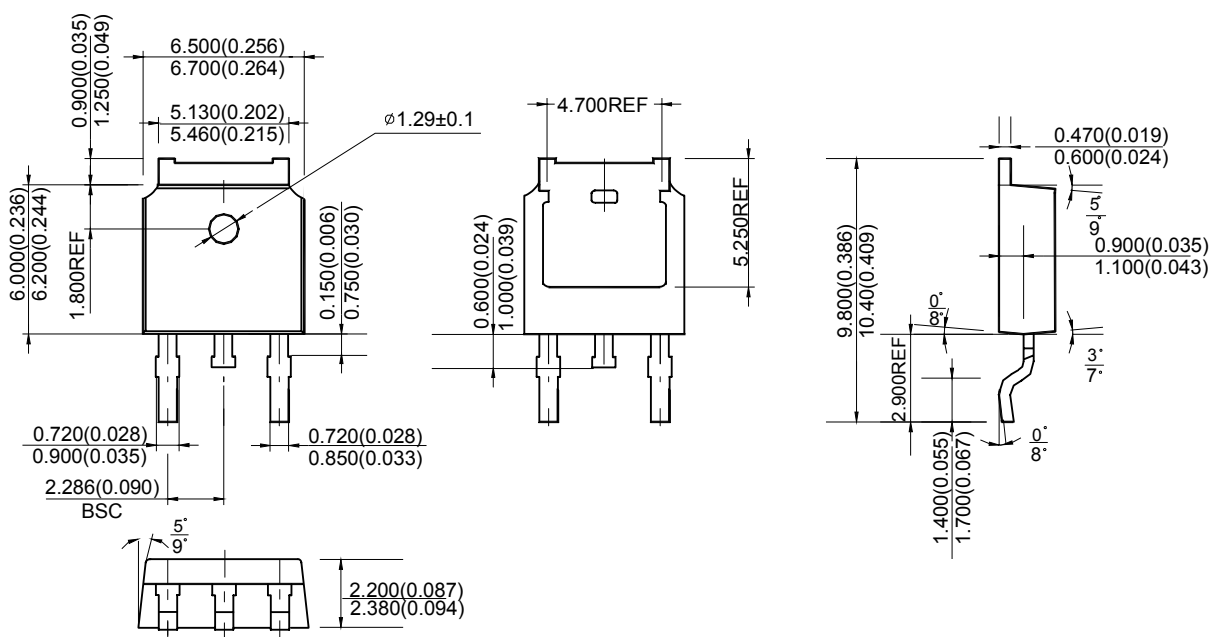



LOW DROPOUT LINEAR REGULATOR

AZ1117B

Mechanical Dimensions (Continued)

SOT-89

Unit: mm(inch)

