

Normal Mode for Signal Line, Through-Hole Type, Bead Lead Type Series

Overview

The KEMET lead type beads intended for normal mode noise suppression have a wide variety of characteristics. These through-hole beads are designed with our proprietary ferrite material and are suitable for noise countermeasure in DC signal line circuits.

Applications

- Audio-visual equipment
- Office automation equipment
- Digital appliances
- Home appliances
- Power supplies

Benefits

- Proprietary Nickel-Zinc (Ni-Zn) ferrite core
- High loss
- High reliability
- Operating temperature range from -20°C to +70°C
- RoHS Compliant



Part Number System

B-	01-	R	T
Series	Impedance (Ω)	Lead Type	Packaging Type
Bead	01 = 2 Ω 02 = 4 Ω 03 = 5 Ω 06 = 40 Ω	A A1 A2 R R-25 R-50 RS	Blank = Bulk T = Tape & Reel TF = Flat taping

Dimensions – Millimeters

Part Number	Dimensions - Millimeters
B-01-R	<p>Technical drawing of B-01-R component. Side view shows a lead length of 13 max, a total height of 20 min, and a lead diameter of 10±2.0. The base width is 5.0. End view shows a lead diameter of 0.65 (Tin coated soft copper wire), a lead diameter of 3.4±0.2, and a lead length of 4.4±0.2.</p>
B-01-RS	<p>Technical drawing of B-01-RS component. Side view shows a lead length of 7.5 max, a total height of 20 min, and a lead diameter of 10±2.0. The base width is 5.0. End view shows a lead diameter of 0.65 (Tin coated soft copper wire), a lead diameter of 3.4±0.2, and a lead length of 4.4±0.2.</p>
B-01-A	<p>Technical drawing of B-01-A component. Top view shows a lead diameter of 3.4±0.2, a lead length of 4.4±0.2, a lead diameter of 0.65 (Tin coated soft copper wire), and a total width of 67±2.0.</p>
B-01-A1	<p>Technical drawing of B-01-A1 component. Side view shows a lead length of 12.5±0.8, a total height of 6.5, a lead diameter of 4.4±0.2, and a lead length of 4.5±1.0. End view shows a lead diameter of 3.4±0.2, a lead diameter of 0.65 (Tin coated soft copper wire), and a lead length of 4.5±1.0.</p>
B-01-A2	<p>Technical drawing of B-01-A2 component. Side view shows a lead length of 10±0.8, a total height of 6.5, a lead diameter of 4.4±0.2, and a lead length of 4.5±1.0. End view shows a lead diameter of 3.4±0.2, a lead diameter of 0.65 (Tin coated soft copper wire), and a lead length of 4.5±1.0.</p>

Dimensions – Millimeters cont.

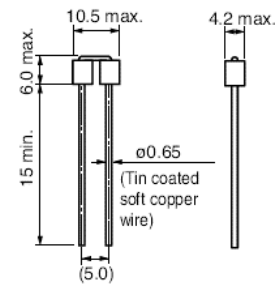
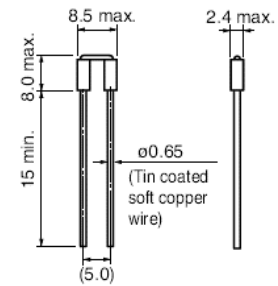
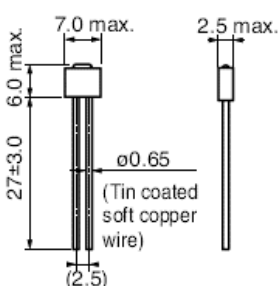
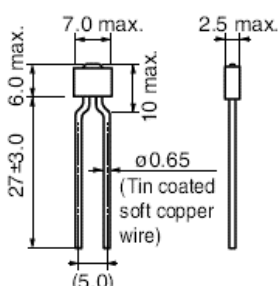
Part Number	Dimensions - Millimeters
B-02-R	
B-03-R	
B-06-R-25	
B-06-R-50	

Environmental Compliance

All KEMET DC line filters are RoHS Compliant.



Performance Characteristics

Item	Performance Characteristics
Rated Current	5 A
Impedance Range	2 – 40 Ω
Shape	Single-bead and double-bead
Lead Type	Axial and radial
Operating Temperature	-20°C to +70°C (not including self-temperature rise)

Table 1 – Ratings & Part Number Reference

Part Number	Rated Current DC ¹ (A)	Impedance (Ω)	Shape	Lead Type	Weight (g)
B-01-R	5	2 at 1 MHz	Single-bead	Radial	0.40
B-01-RT	5	2 at 1 MHz	Single-bead	Radial	0.40
B-01-RTF	5	2 at 1 MHz	Single-bead	Radial	0.40
B-01-RS	5	2 at 1 MHz	Single-bead	Radial	0.40
B-01-RTS	5	2 at 1 MHz	Single-bead	Radial	0.40
B-01-RTSF	5	2 at 1 MHz	Single-bead	Radial	0.40
B-01-A	5	2 at 1 MHz	Single-bead	Axial	0.40
B-01-A1	5	2 at 1 MHz	Single-bead	Axial	0.30
B-01-A2	5	2 at 1 MHz	Single-bead	Axial	0.30
B-01-AT	5	2 at 1 MHz	Single-bead	Axial	0.40
B-01-ATF	5	2 at 1 MHz	Single-bead	Axial	0.40
B-01-AT1F	5	2 at 1 MHz	Single-bead	Axial	0.30
B-02-R	5	4 at 1 MHz	Double-bead	Radial	0.60
B-02-RT	5	4 at 1 MHz	Double-bead	Radial	0.60
B-02-RTF	5	4 at 1 MHz	Double-bead	Radial	0.60
B-03-R	5	5 at 1 MHz	Double-bead	Radial	0.30
B-03-RT	5	5 at 1 MHz	Double-bead	Radial	0.30
B-06-R-25	5	40 at 10 MHz	Double-bead	Radial	0.50
B-06-RTF-25	5	40 at 10 MHz	Double-bead	Radial	0.50
B-06-R-50	5	40 at 10 MHz	Double-bead	Radial	0.50
B-06-RTF-50	5	40 at 10 MHz	Double-bead	Radial	0.52

¹ Rated current values are not guaranteed by impedance levels; these values are permissible levels when the lead wire temperature rise is 20°C.

Frequency Characteristics

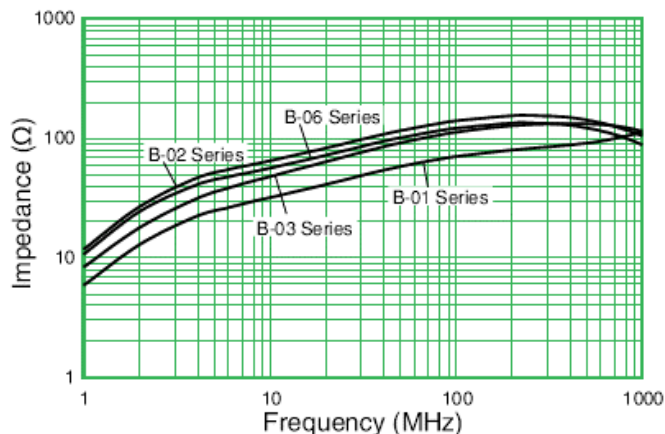

Packaging

Part Type	Packaging Type	Pieces per Package	Pieces per Box
B-01-R	Bulk	100	18,000
B-01-RT	Tape & Reel	2,000	12,000
B-01-RTF	Flat taping	2,000	20,000
B-01-RS	Bulk	100	18,000
B-01-RTS	Tape & Reel	2,000	12,000
B-01-RTSF	Flat taping	2,000	20,000
B-01-A	Bulk	100	18,000
B-01-A1	Bulk	250	30,000
B-01-A2	Bulk	250	30,000
B-01-AT	Tape & Reel	5,000	20,000
B-01-ATF	Flat taping	1,500	15,000
B-01-AT1F	Flat taping	2,000	32,000
B-02-R	Bulk	100	12,000
B-02-RT	Tape & Reel	2,000	12,000
B-02-RTF	Flat taping	1,500	15,000
B-03-R	Bulk	100	18,000
B-03-RT	Tape & Reel	2,000	12,000
B-06-R-25	Bulk	100	12,000
B-06-RTF-25	Flat taping	1,500	15,000
B-06-R-50	Bulk	100	12,000
B-06-RTF-50	Flat taping	1,500	15,000

Taping Specifications

B-01-R**

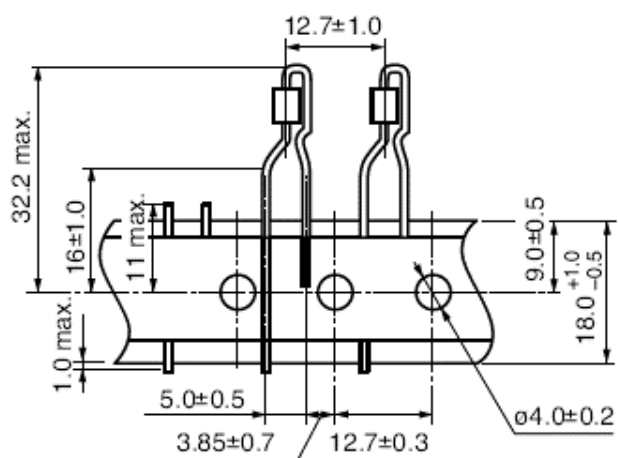

B-01-RS**

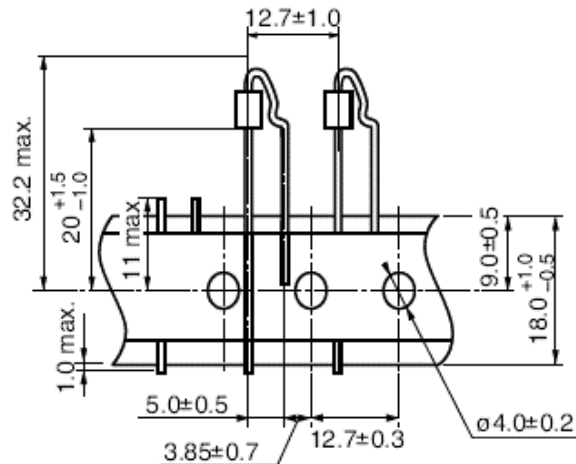

B-01-A**

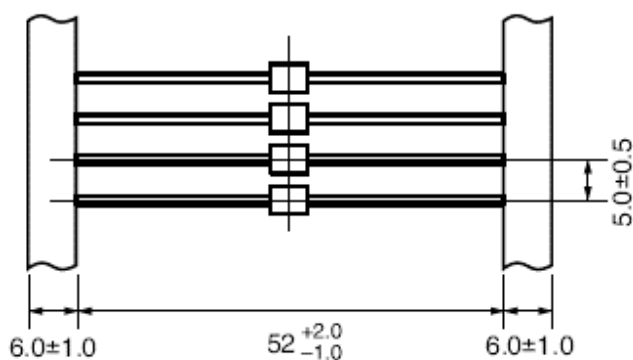

B-01-A1**

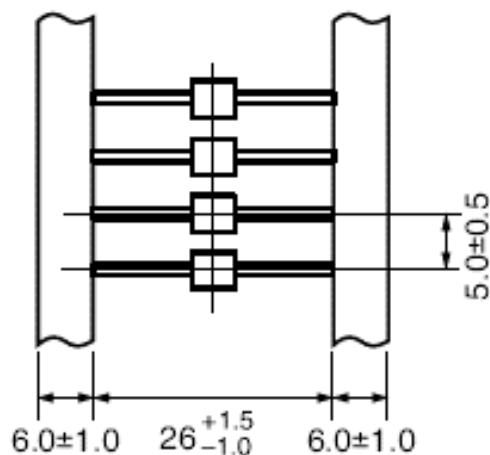

B-02-R** & B-03-R*

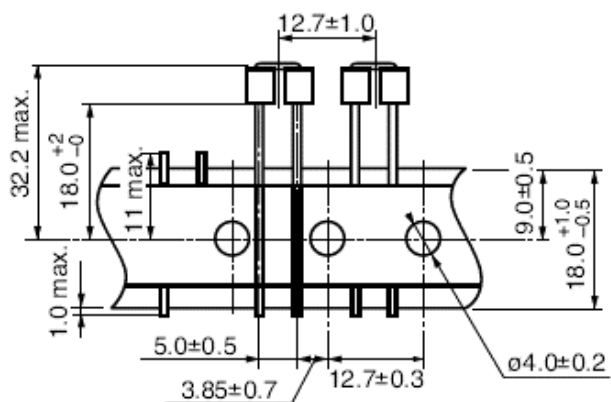

B-06-RTF25

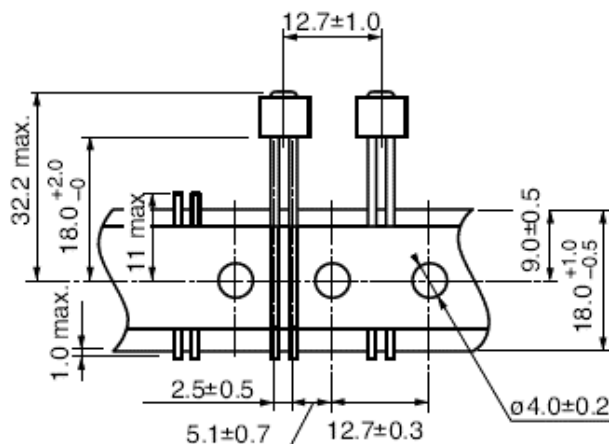

Taping Specifications cont.

B-06-RTF50

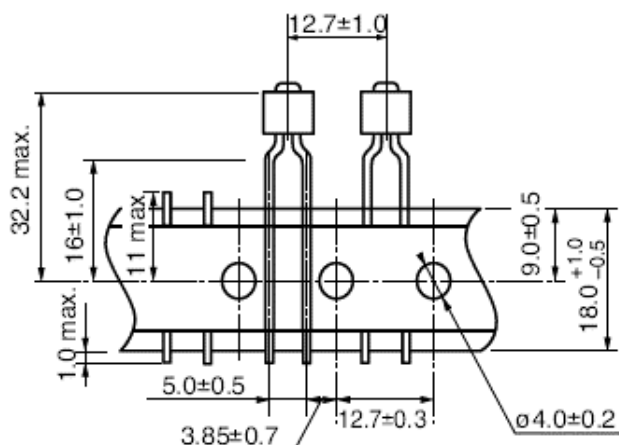

Reel Specifications

Reel Dimensions - Millimeters

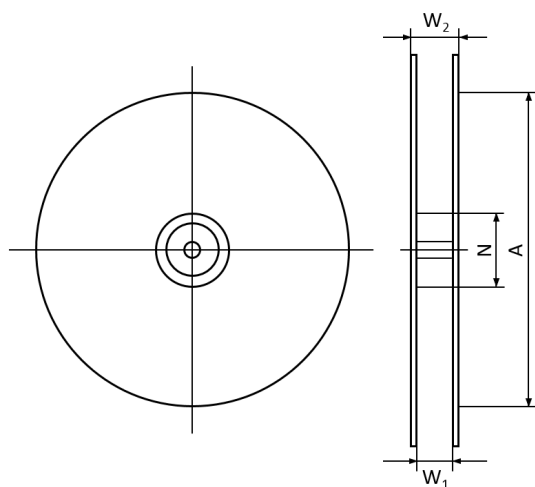

Part Number	A	N	W ₁ +1.0, -0.0	W ₂ Maximum
B-01-AT	360.0	81.0	68.0	73.2
B-01-RT	360.0	140.0	44.0	50.2
B-01-RTS	360.0	140.0	44.0	50.2
B-02-RT	360.0	140.0	44.0	50.2
B-03-RT	360.0	140.0	44.0	50.2

Handling Precautions

Precautions for product storage

DC Line Filters should be stored in normal working environments. While the chokes themselves are quite robust in other environments, solderability will be degraded by exposure to high temperatures, high humidity, corrosive atmospheres, and long term storage.

KEMET recommends that maximum storage temperature not exceed 40°C and maximum storage humidity not exceed 70% relative humidity. Atmospheres should be free of chlorine and sulfur bearing compounds. Temperature fluctuations should be minimized to avoid condensation on the parts. Do not store near strong magnetic fields, as this might magnetize the product.

For optimized solderability, DC line filter stock should be used promptly, preferably within six months of receipt.

Product temperature rise values

The values listed for temperature rise are the result of self-heating in wires when the rated current (commercial frequency) is applied. When using, check and evaluate the value of the core temperature rise under actual operating conditions.

Export Control

For customers in Japan

For products that are controlled items subject to the “Foreign Exchange and Foreign Trade Law” of Japan, the export license specified by the law is required for export.

For customers outside Japan

DC Line Filters should not be used or sold for use in the development, production, stockpiling or utilization of any conventional weapons or mass-destructive weapons (nuclear weapons, chemical or biological weapons, or missiles) or any other weapons.