

B0540WS-HF

RoHS Device
Halogen Free



Features

- Low forward voltage drop.
- Guard ring construction for transient protection.
- High conductance.

Mechanical data

- Case: Molded plastic, SOD-323.
- Molding compound, UL flammability classification rating 94V-0.
- Terminals: Tin plated leads, solderable per MIL-STD-202, method 208.
- Polarity: Cathode line denotes the cathode end.

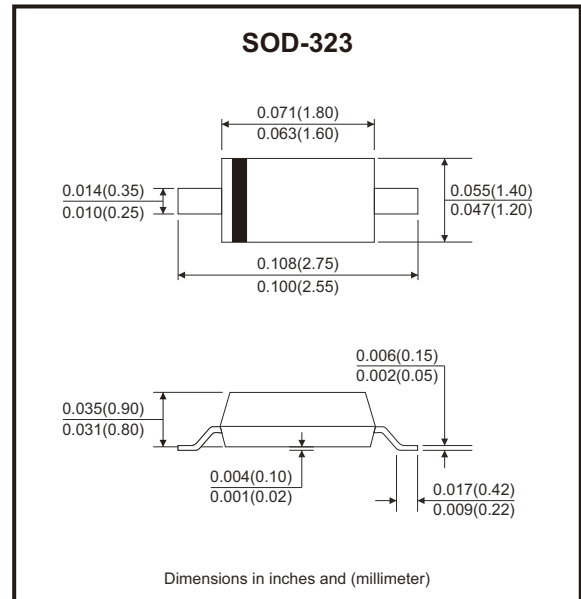

Circuit Diagram



Maximum Rating (at Ta=25°C unless otherwise noted)

Parameter	Symbol	Value	Unit
Peak repetitive reverse voltage	V_{RRM}	40	V
RMS reverse voltage	V_{RMS}	28	V
Average rectified output current	I_O	0.5	A
Peak forward surge current , 8.3ms single half-sine-wave	I_{FSM}	10	A
Power dissipation	P_D	250	mW
Typical thermal resistance per leg (Note 1)	$R_{\theta JA}$	500	°C/W
Operating junction temperature range	T_J	-55 to +150	°C
Storage temperature range	T_{STG}	-55 to +150	°C

Note: 1. Part mounted on FR-4 board with recommended pad layout.

Electrical Characteristics (at Ta=25°C unless otherwise noted)

Parameter	Symbol	Conditions	Min	Max	Unit
Forward voltage <small>(Note 1)</small>	V_F	$I_F = 0.5A$ $I_F = 1A$		0.51 0.62	V
Max. peak reverse current <small>(Note 2)</small>	I_R	$V_R = 20V$ $V_R = 40V$		10 20	μA
Capacitance between terminals	C_T	$V_R = 0V, f = 1MHz$		170	pF
Reverse recovery time	t_{rr}	$I_F = I_R = 10mA, I_{rr} = 0.1 \times I_R, R_L = 100\Omega$		4	ns

Notes: 1. Pulse width $\leq 380\mu s$, duty cycle $< 2\%$.
2. Pulse test, $t_p \leq 5ms$.

Rating and Characteristic Curves (B0540WS-HF)

Fig.1 - Typical Reverse Characteristic

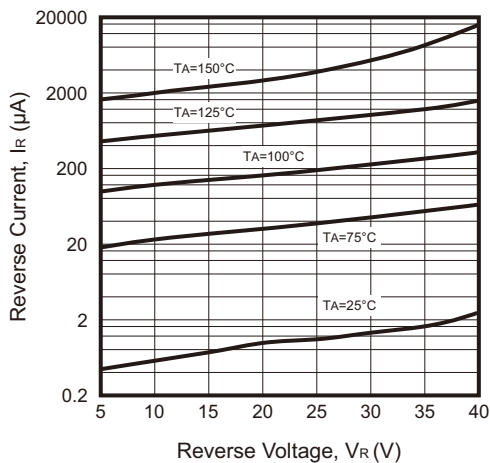

Fig.2 - Typical Forward Characteristic

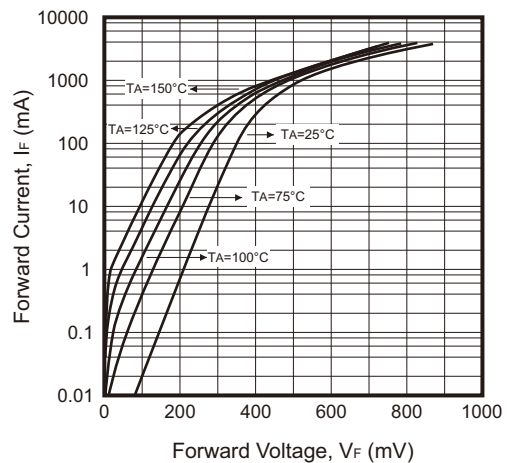

Fig.3 - Capacitance vs Reverse Voltage

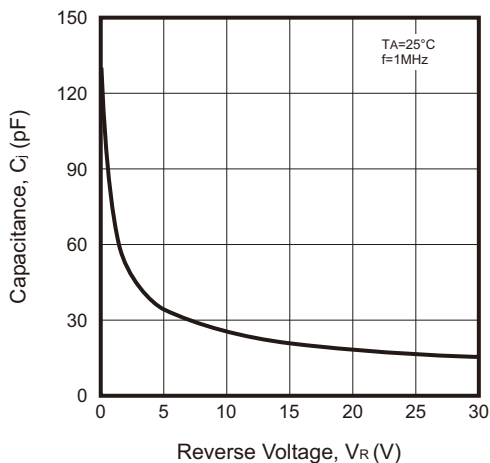
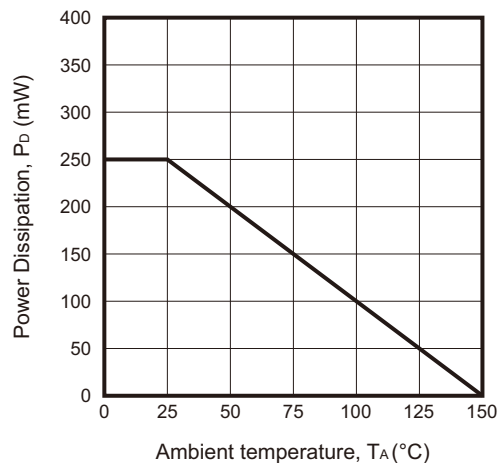
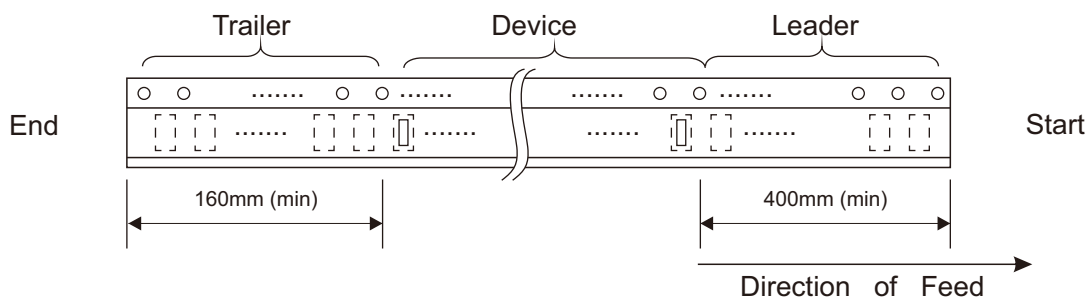
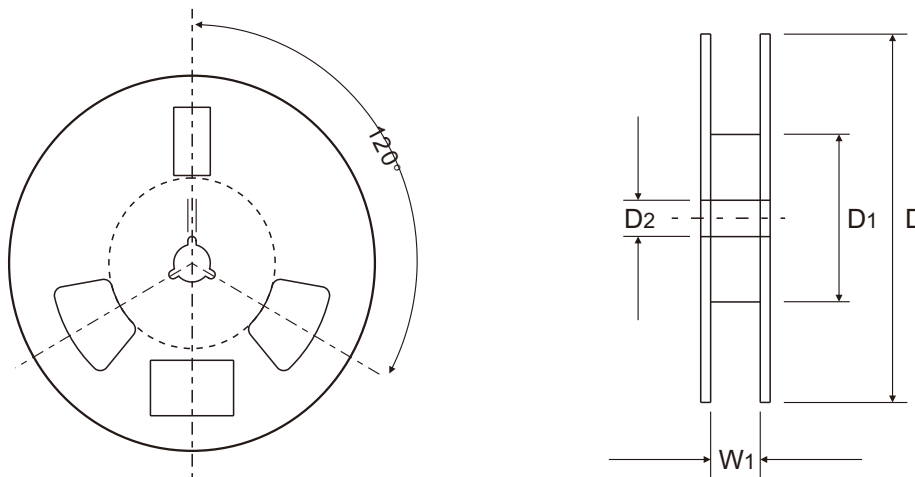
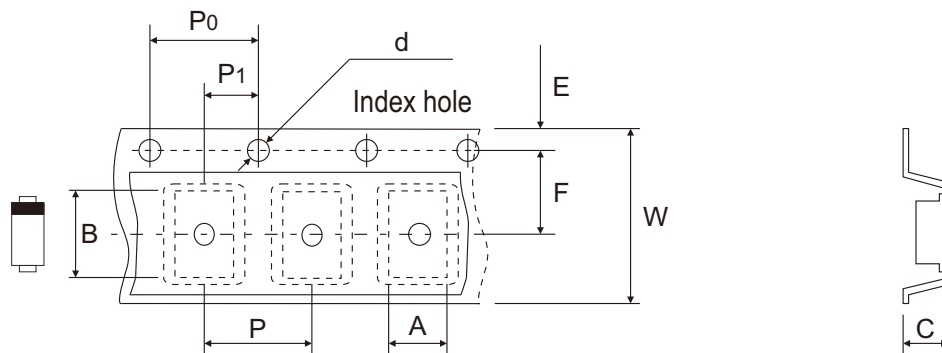

Fig.4 - Derating Curve (P_D - T_A)



Company reserves the right to improve product design, functions and reliability without notice.

Reel Taping Specification



SOD-323	SYMBOL	A	B	C	d	D	D1	D2
	(mm)	1.46 ± 0.05	3.30 ± 0.05	1.25 ± 0.05	1.50 + 0.10	178.00 ± 1.00	54.00 ± 0.50	13.00 ± 0.50
	(inch)	0.057 ± 0.002	0.130 ± 0.002	0.049 ± 0.002	0.059 + 0.004	7.008 ± 0.039	2.126 ± 0.020	0.512 ± 0.020

SOD-323	SYMBOL	E	F	P	P0	P1	W	W1
	(mm)	1.75 ± 0.10	3.50 ± 0.05	4.00 ± 0.10	4.00 ± 0.10	2.00 ± 0.05	8.00 + 0.30 - 0.10	9.50 ± 1.00
	(inch)	0.069 ± 0.004	0.138 ± 0.002	0.157 ± 0.004	0.157 ± 0.004	0.079 ± 0.002	0.315 + 0.012 - 0.004	0.374 ± 0.039

Company reserves the right to improve product design, functions and reliability without notice.

REV:A