

DATA SHEET

GAS DISCHARGE TUBES TELEPHONE INTERFACE

B32 series

RoHS compliant & free



Product specification— February 02, 2021 V.1



Gas Discharge Tube (GDT) Data Sheet

Features

- High insulation resistance
- Low capacitance ($\leq 0.5\text{pF}$)
- 500A 8/20 μs maximum surge current capacity in accordance with IEC61000-4-5
- 4KV 10/700 μs maximum surge rating in accordance with ITU-TK.21
- Surface mounted gas arrester
- Micro-Gap Design
- Size 3216(1206)
- Storage and operating temperature: $-40^{\circ}\text{C} \sim +85^{\circ}\text{C}$
- Meets MSL level 1, per J-STD-020
- Safety certification: UL



Applications

- Repeaters, Modems
- Telephone Interface, Line cards
- Data communication equipment
- Line test equipment

Part Number Code

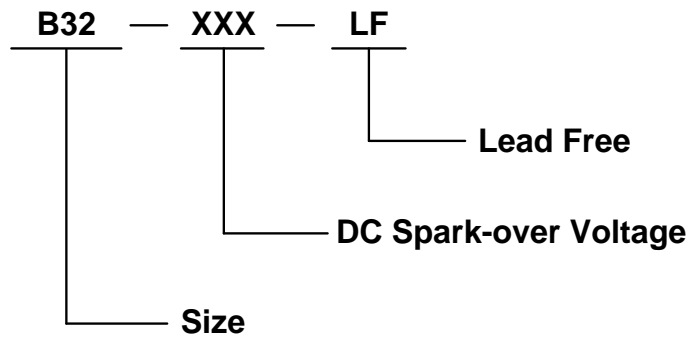

Dimensions

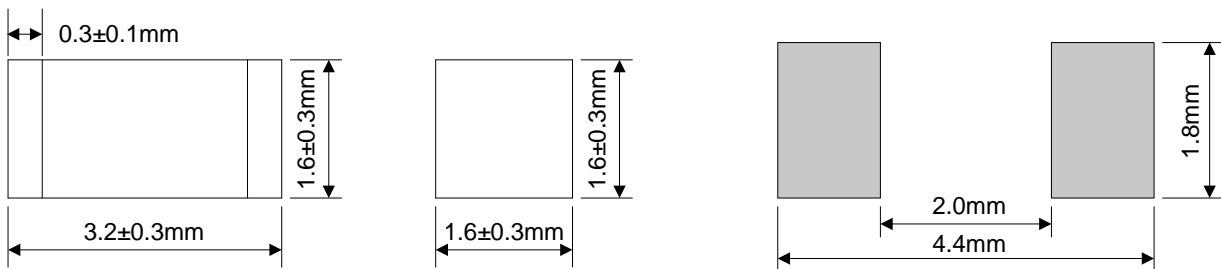

Recommended Pad Size

Electrical Characteristics

Part Number	DC Spark-over Voltage	Maximum Impulse Spark-over Voltage	Minimum Insulation Resistance		Maximum Capacitance	Nominal Impulse Discharge Current	Impulse Withstanding Voltage Capacity	Device Marking Code
	100V/s	1000V/ μ s	Test Voltage	(G Ω)	(1MHz)	8/20 μ s 10 Times	10/700 μ s 10 Times	
	(V)	(V)	DC(V)		(pF)	(A)	(KV)	
B32-150-LF	150 \pm 30%	750	50	1	0.5	500	4	None
B32-200-LF	200 \pm 30%	900	100	1	0.5	500	4	None
B32-230-LF	230 \pm 30%	950	100	1	0.5	500	4	None
B32-300-LF	300 \pm 30%	1000	100	1	0.5	500	4	None
B32-350-LF	350 \pm 30%	1100	100	1	0.5	500	4	None
B32-400-LF	400 \pm 30%	1100	100	1	0.5	500	4	None
B32-420-LF	420 \pm 30%	1200	100	1	0.5	500	4	None
B32-470-LF	470 \pm 30%	1200	100	1	0.5	500	4	None

Electrical Ratings

Items	Test Condition/Description	Requirement
DC Spark-over Voltage	The voltage is measured with voltage ramp $dv/dt=100V/s$.	To meet the specified value
Maximum Impulse Spark-over Voltage	The maximum impulse spark-over voltage is measured with voltage ramp $dv/dt=1000V/\mu s$.	
Insulation Resistance	The resistance of gas tube shall be measured between two electrodes.	
Capacitance	The capacitance of gas tube shall be measured between two electrodes. Test frequency: 1MHz	
Impulse Discharge Current	Maximum 8/20 μs surge current that can be applied between two electrodes, 5 positive and 5 negative surges, with 3 minutes interval time.	
Impulse Withstanding Voltage	The maximum 10/700 μs surge that can be applied to the Gas Tube, 5 positive and 5 negative surges, with 1 minute interval time.	

Reliability

Items	Test conditions / Methods	Standard
Cold Resistance	Measurement after -40 °C /1000 HRS & normal temperature/2 HRS.	Features are conformed to rated spec.
Heat Resistance	Measurement after 125 °C /1000 HRS & normal temperature/2 HRS.	
Humidity Resistance	Measurement after humidity 90~95°C(45°C) /1000 HRS & normal temperature/2 HRS.	
Temperature Cycle	10 times repetition of cycle -40°C/30min →normal, temp/2 min →125°C/30min, measurement after normal temp/2 HRS.	
Solder Ability	Check for solder adhesion after 260±5°C for 3sec , The body immersion depth 1.5mm in molten solder	Evenly covered by solder.
Solder Heat	Measurement after 260±5°C solder for 10sec, The body immersion depth 1.5mm in molten solder	Conformed to rated spec.

Recommended Soldering Conditions

