



NTC thermistors for inrush current limiting

Inrush Current Limiters (ICLs)

Series/Type: S364/120/M
Ordering code: B57364S0121M000
Date: 2016-01-11
Version: d

© EPCOS AG 2015. Reproduction, publication and dissemination of this publication, enclosures hereto and the information contained therein without EPCOS' prior express consent is prohibited.

EPCOS AG is a TDK Group Company.

Data sheet

Application

- Inrush current limiting, e.g. in switch-mode power supplies, soft-start motors

Features

- Leaded and coated NTC thermistors
- Tinned copper wire, kinked
- Coating material flame retardant to UL 94 V-0
- Manufacturer's logo, NTC and resistance value stamped on
- Highly stable electrical characteristics
- IEC approval (certification number 101QA12)
- VDE approval (certification number 40038223)
- CQC approval (certification number CQC09001040539)
- RoHS-compatible

Data sheet

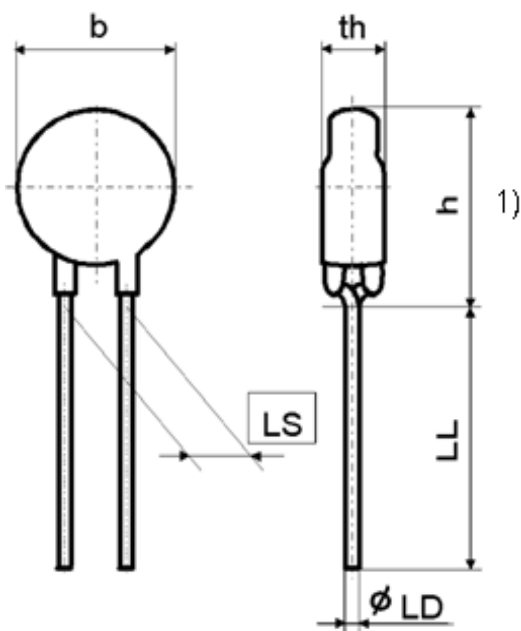
Drawing

b	21.0 max	mm
th	7.0 max	mm
h	28.0 max	mm
LL	25.0 min	mm
LD	1.0 ±0.05	mm
LS	7.5 ±0.8	mm

1) Seating plane to IEC 60717

Approx. weight: 4 g

General technical data

Climatic category	(IEC 60068-1)	P_{max}	55/170/21	
Max. power	(at 25 °C)	$\Delta R_R/R_R$	5.1	W
Resistance tolerance		T_R	± 20	%
Rated temperature		δ_{th}	25	°C
Dissipation factor	(in air)	τ_{th}	approx. 24	mW/K
Thermal cooling time constant	(in air)	C_{th}	approx. 100	s
Heat capacity			approx. 2400	mJ/K

Electrical specification and ordering codes

R_{25}	I_{max} (0...65 °C)	C_{test} at 230 V AC	C_{test} at 110 V AC	R_{min} (at I_{max} , 25 °C)	Ordering code
Ω	A	μF	μF	Ω	
120	3.5	1000	4000	0.427	B57364S0121M000

Data sheet

Maximum continuous current I_{max}

The I_{max} denotes the maximum permissible continuous current (DC or RMS values for sine-shaped AC) in the temperature range from 0 to 65 °C.

Load derating (I / I_{max})

The power handling capability of an NTC thermistor cannot be fully utilized over the entire temperature range. For circuit dimensioning the derating curve given below provides information on the extent to which the current must be reduced at a certain ambient temperature (T_A).

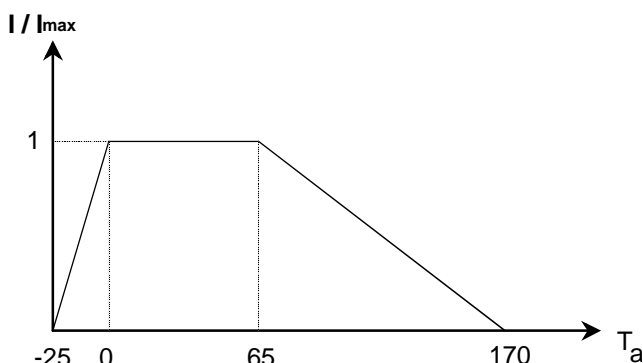

$$\text{Percent of } I_{max} = 100 \left[1 - \frac{T_A - 65^\circ C}{T_{max} - 65^\circ C} \right]$$

T_A = ambient temperature ($T_A > 65^\circ C$)
 $T_{max} = 170^\circ C$

Fig. 1 Maximum current derating (I / I_{max})

Maximum permissible capacitance

The currents during turn-on are much higher than the rated currents during continuous operation. To test the effects of these current surges EPCOS uses the following standard procedure according to IEC 60539-1:

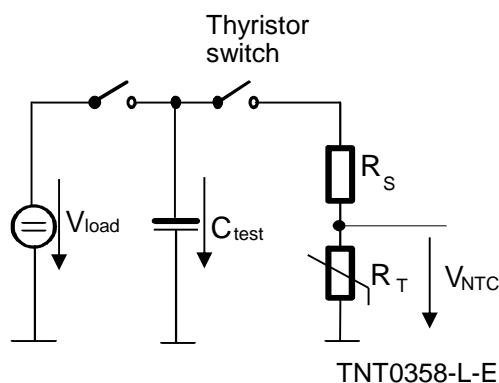

V_{load} Load voltage [V]
 C_{test} Test capacitance [μF]
 R_s Series resistance [$R_s = 1 \Omega$]
 V_{NTC} Voltage drop across the NTC under test [V]
 $= 180/375 V$
 (corresponds $(110/230 V + dV) \times 1.41$)

Fig. 2 Maximum switchable capacity measuring circuit

Marking

- EPCOS – logo
- Resistance value
- NTC
- Date code with 4 digits (year and week of production): 1635 (example for week 35 in year 2016)

Data sheet

Reliability data

Test	Standard	Test conditions	$\Delta R_{25}/R_{25}$ (typical)	Remarks
Storage in dry heat	IEC 60068-2-2	Storage at upper category temperature T: 170°C t: 1 000 h	< 20 %	No visible damage
Storage in damp heat, steady state	IEC 60068-2-78	Temperature of air: 40°C Relative humidity of air: 93 % Duration: 21 days	< 20 %	No visible damage
Rapid change of temperature	IEC 60068-2-14	Lower test temperature: -55 °C t: 30 min Upper test temperature: 170 °C t: 30 min Time to change from lower to upper temperature: < 30 s Number of cycles: 10	< 20 %	No visible damage
Endurance with max. current	IEC 60539-1	Ambient temperature: 25 ± 5 °C I = I _{max} t: 1000 h	< 20 %	No visible damage
Cyclic endurance	IEC 60539-1	Ambient temperature: 25 ± 5 °C I = I _{max} On-time = 1 min Cooling time = 5 min Number of cycles: 1000	< 20 %	No visible damage
Maximum permissible capacitance test	IEC 60539-1	Ambient temperature: 25 ± 5 °C Capacitance = C _{test} Number of cycles: 1000	< 20 %	No visible damage

Note

- The self-heating of a thermistor during operation depends on the load applied and the applicable dissipation factor.
- When loaded with maximum allowable current/power and the specified dissipation factor is taken as a basis, the NTC thermistor may reach a mean temperature of up to 250 °C.
- The heat developed during operation will also be dissipated through the lead wires. So the contact areas, too, may become quite hot at maximum load.
- When mounting NTC thermistors you have to ensure that there is an adequate distance between the thermistor and all parts which are sensitive to heat or combustible.

Data sheet
Solderability

Test to IEC 60068-2-20

Preconditioning: Immersion into flux F-SW 32.

Evaluation criterion: Wetting of soldering areas $\geq 95\%$.

Solder	Bath temperature (°C)	Dwell time (s)
SnAg (3.0 ... 4.0), Cu (0.5 ... 0.9)	245 \pm 3	3

Resistance to soldering heat

Test to IEC 60068-2-20

Preconditioning: Immersion into flux F-SW 32.

Solder	Bath temperature (°C)	Dwell time (s)
SnAg (3.0 ... 4.0), Cu (0.5 ... 0.9)	260 -5	10

Soldering instructions

When soldering, care must be taken that the NTC thermistors are not damaged by excessive heat. The following maximum temperatures, maximum time spans and minimum distances have to be observed:

	Dip soldering	Iron soldering
Bath temperature .	max. 260 °C	max. 360 °C
Soldering time	max. 4 s	max. 2 s
Distance from thermistor	min. 6 mm	min. 6 mm

Under more severe soldering conditions the resistance may change.

Robustness of terminations

The leads meet the requirements of IEC 60068-2-21.

Test	Test conditions	Remarks
Tensile strength	Test Ua1: Fasten body with a force applied to each lead 10 N for 10 s	No visible damage
Bending strength	Test Ub: Fasten body with two 90°-bends in opposite direction at a force of 10 N	No visible damage

Remark: Peel off of coating along the lead is accepted.

Data sheet

Resistance versus temperature

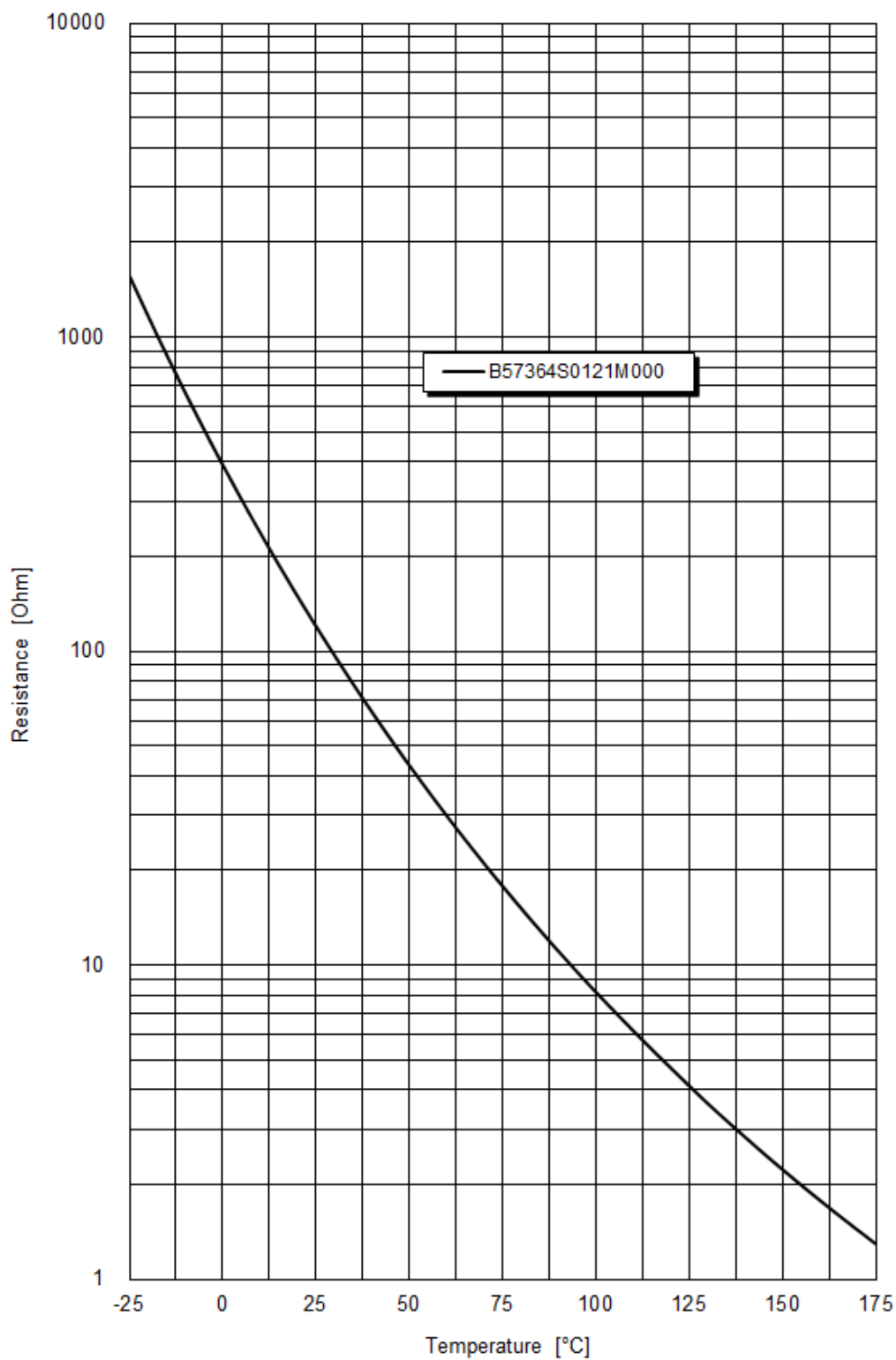

Data sheet

Resistance versus current

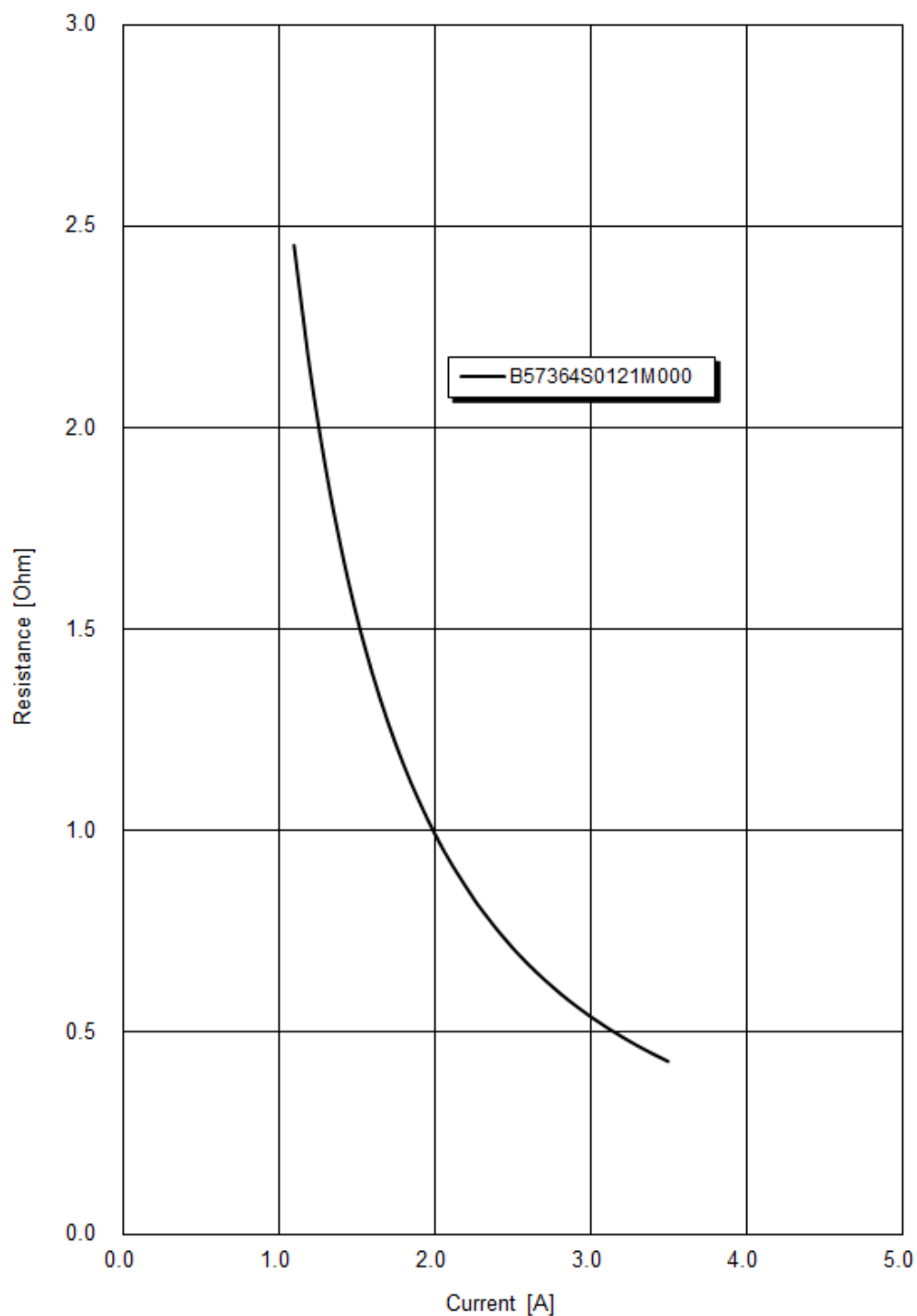

Data sheet

Packing

Packing	Pcs / unit	Dimensions (mm)
Bulk	250	Approx. x= 240, y= 160, z= 80

Bar code label

The packing of all EPCOS components bears a bar code label stating the type, ordering code, quantity, date of manufacture and batch number. This enables a component to be traced back through the production process, together with its batch and test report.

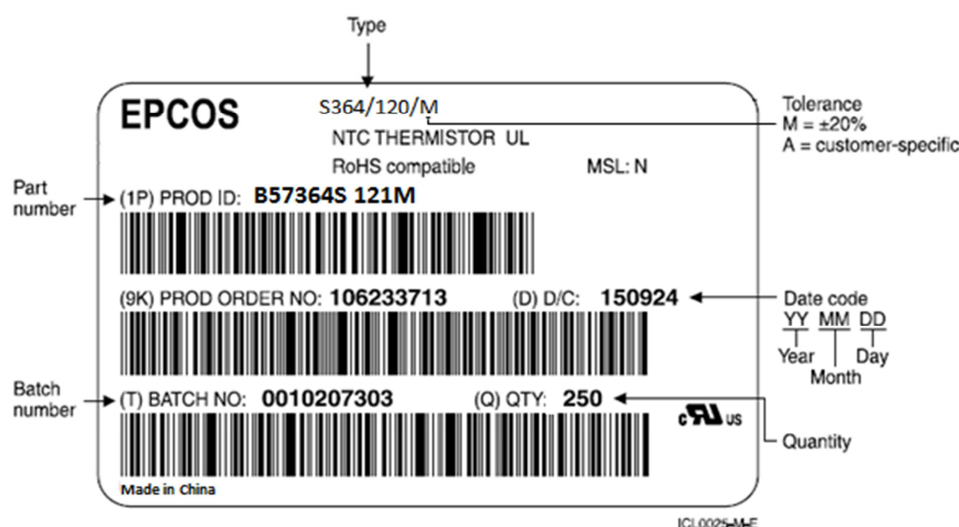

Internal construction

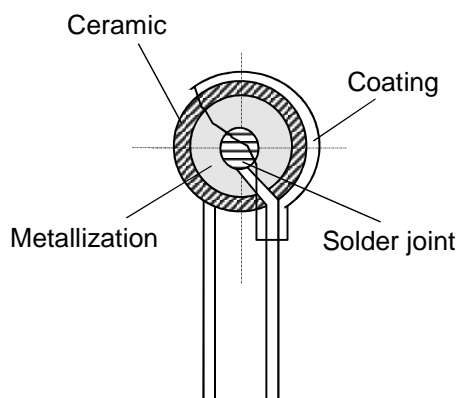

The above picture shows the internal construction of EPCOS ICLs.

Note: Coating may have cracks or chips due to acting mechanical force on the wire, but this does not affect the performance of the component.

Data sheet

Cautions and warnings

See "Important notes" of this data sheet.

Storage

- Store thermistors only in original packaging. Do not open the package before storage.
- Storage conditions in original packaging: storage temperature -25 °C ... +45 °C, relative humidity ≤75% annual mean, maximum 95%, dew precipitation is inadmissible.
- Avoid contamination of thermistors surface during storage, handling and processing.
- Avoid storage of thermistor in harmful environments like corrosive gases (SO_x, Cl etc).
- Solder thermistors after shipment from EPCOS within the time specified:
 - Leaded components: 24 months

Handling

- NTC inrush current limiters must not be dropped. Chip-offs must not be caused during handling of NTC inrush current limiters.
- Components must not be touched with bare hands. Gloves are recommended.
- Avoid contamination of thermistor surface during handling.
- In case of exposure of the NTC inrush current limiters to water, electrolytes or other aggressive media, these media can penetrate the coating and reach the surface of the ceramic. Low-ohmic or high-ohmic behavior may occur due to the formation of an electrolyte with metals (silver/lead/tin from metallization or solder). Low-ohmic behavior is caused by electrochemical migration, high-ohmic behavior by dissolving of the electrode. In either case, the functionality of the NTC inrush current limiters can not be assured.
- Washing processes may damage the product due to the possible static or cyclic mechanical loads (e.g. ultrasonic cleaning). They may cause cracks to develop on the product and its parts, which might lead to reduced reliability or lifetime.

Bending / twisting leads

- A lead (wire) may be bent at a minimum distance of twice the wire's diameter plus 4 mm from the component head or housing. When bending ensure the wire is mechanically relieved at the component head or housing. The bending radius should be at least 0.75 mm.
- Twisting (torsion) by 180° of a lead bent by 90° is permissible at 6 mm from the bottom of the thermistor body.

Soldering

- Use resin-type flux or non-activated flux.
- Insufficient preheating may cause ceramic cracks.
- Rapid cooling by dipping in solvent is not recommended.
- Complete removal of flux is recommended.