



NTC thermistors for temperature measurement

NTC Probes

Series/Type:	M703/4,7k/3%
Ordering code:	B57703M0472A007
Date:	2011-08-26
Version:	1

Datasheet
Application

High-accuracy surface temperature measurement, e.g. on housings and pipes

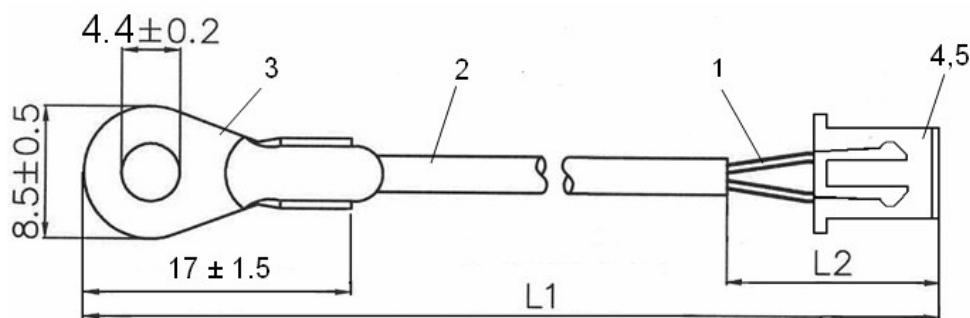

L1 : 330 ± 10

Dimensions in mm, Tolerances acc. to ISO 2768-m unless specified

L2 : 14 mm max

Version:

Thermistor encapsulated in metal-tag case (material: brass, tinned)

wire: AWG 28 stranded (19 x Ø0.07 mm, copper, silver-plated), Insulation: PTFE, blue

No.	Item	Material	Property	Remarks
1	wire	Cu silver-plated	AWG28 (19 x 0.07	PTFE insulated, blue
2	shrink tube	polyolefine	125°C, UL224, VW-1	black
3	ring tongue	brass, tinned		
4	crimp contact	phosphor bronze, tinned	JST SXH-002T-P0.6	
5	connector	PA6	JST XHP-2	white

Ratings and Characteristics

Climatic Category (IEC 60068-1)

Lower category temperature

Higher category temperature

: -25/125/56

[°C] : -25

[°C] : 125

Rated resistance R_N // Tolerance

Rated temperature

B-value : $B_{(25/100)}$ // Tolerance

R/T-Curve no. // R_{25}

R_N [Ω // %] : 4700 // ± 3

T_N [°C] : 25

B_N [K//%]: 3988 // ± 1.5

[n//Ω]: 8016 // 4700

Power rating at 25°C

Dissipation factor (air)

Thermal cooling time constant (in air)

Heat capacity

P_{25} [mW]: 150

δ_{th} [mW/K] : approx. 3 *

τ_C [s] : approx. 50 *

C_{th} [mJ/K] : approx. 150 *

Test voltage between ring tongue and connector connector pins (50 Hz, 1s)

[V_{AC}] : 2700

* Typical values, depends on mounting situation

Remarks:

UL approved type, File E69802, Vol.2, Sec.17

the connector is specified for a temperature range from -25°C to +85°C

NTC-RESISTANCE-TEMPERATURE-CURVE

R/T-Curve = 8016 / A01

B(25/100) = 3988 K ± 1.5 %

R at 25 °C = 4700 Ω

 R_N at 25 °C = 4700 Ω ± 3.0%

Temp. [°C]	R Nom [Ω]	R Min [Ω]	R Max [Ω]	ΔR [±%]	ΔT [±°C]	α [%/K]
-25	61274	56928	65620	7,1	1,2	6,0
-20	45623	42604	48642	6,6	1,1	5,8
-15	34277	32166	36388	6,2	1,1	5,6
-10	26005	24518	27492	5,7	1,0	5,4
-5	19888	18835	20941	5,3	1,0	5,3
0	15346	14596	16095	4,9	1,0	5,1
5	11932	11396	12468	4,5	0,9	5,0
10	9353	8968	9738	4,1	0,9	4,8
15	7383	7106	7659	3,7	0,8	4,7
20	5870	5671	6069	3,4	0,8	4,5
25	4700	4559	4841	3,0	0,7	4,4
30	3787	3659	3915	3,4	0,8	4,3
35	3070	2956	3183	3,7	0,9	4,1
40	2504	2403	2604	4,0	1,0	4,0
45	2053	1965	2142	4,3	1,1	3,9
50	1693	1615	1771	4,6	1,2	3,8
55	1404	1335	1472	4,9	1,3	3,7
60	1169	1109	1230	5,2	1,4	3,6
65	979,0	925,9	1032	5,4	1,5	3,5
70	823,4	776,7	870,2	5,7	1,7	3,4
75	696,2	654,9	737,5	5,9	1,8	3,3
80	591,3	554,8	627,8	6,2	1,9	3,2
85	504,0	471,7	536,3	6,4	2,0	3,2
90	431,3	402,7	460,0	6,6	2,2	3,1
95	370,6	345,2	396,0	6,9	2,3	3,0
100	319,6	297,0	342,2	7,1	2,4	2,9
105	276,6	256,5	296,8	7,3	2,6	2,9
110	240,3	222,2	258,3	7,5	2,7	2,8
115	209,3	193,2	225,5	7,7	2,8	2,7
120	183,0	168,5	197,4	7,9	3,0	2,7
125	160,6	147,6	173,6	8,1	3,1	2,6

Datasheet
RELIABILITY DATA :

Test	Test conditions	$\Delta R_{25}/R_{25}$ (typical)	Remarks
Storage in dry heat	Storage at upper category temperature Temperature: 125 °C Duration: 1000 h	< 2 %	No visible damage
Storage in coldness	Storage at lower category temperature Temperature: -25 °C Duration: 1000 h	< 2 %	No visible damage
Storage in damp, heat, steady state	Temperature of air: 40 °C Relative humidity of air: 93 % Duration: 56 days	< 2 %	No visible damage
Rapid change of temperature in air	Lower test temperature: 0 °C (time: ~10 min) Upper test temperature: 100 °C (time: ~10 min) Time to change from lower to upper temperature: < 30 sec; Number of cycles: 10	< 2 %	No visible damage
Voltage proof test	2700 V _{AC} ; 1 s	--	No flash over
Insulation test	The sensors are placed in a vessel containing metallic balls of ≤ 1 mm diameter (with total immersed head) The applied voltage is 500 V _{DC} .	--	ABOVE 100 MΩ

Cautions and warnings

Storage

- Store thermistors in original packaging only. Do not open the package prior to storage.
- Storage conditions in original packaging: storage temperature $-25^{\circ}\text{C} \dots +45^{\circ}\text{C}$, relative humidity $\leq 75\%$ annual mean, maximum 95%, dew precipitation is inadmissible.
- Do not store thermistors where they are exposed to heat or direct sunlight. Otherwise, the packing material may be deformed or components may stick together, causing problems during mounting.
- Avoid contamination of thermistor surface during storage, handling and processing.
- Avoid storage of thermistors in harmful environments like corrosive gases (SO_x , Cl etc.)
- Use the components as soon as possible after opening the factory seals, i.e. the polyvinyl-sealed packages.
- Solder thermistors within the time specified after shipment from EPCOS.
For leaded components this is 24 months.

Handling

- NTC thermistors must not be dropped. Chip-offs or any other damage must not be caused during handling of NTCs.
- Do not touch components with bare hands. Gloves are recommended.
- Avoid contamination of thermistor surface during handling.

Soldering

- Use resin-type flux or non-activated flux.
- Insufficient preheating may cause ceramic cracks.
- Rapid cooling by dipping in solvent is not recommended.
- Complete removal of flux is recommended.